

PRECISION PRODUCTS AND SIGNAL CHAIN SOLUTIONS

Selection Guide 2019

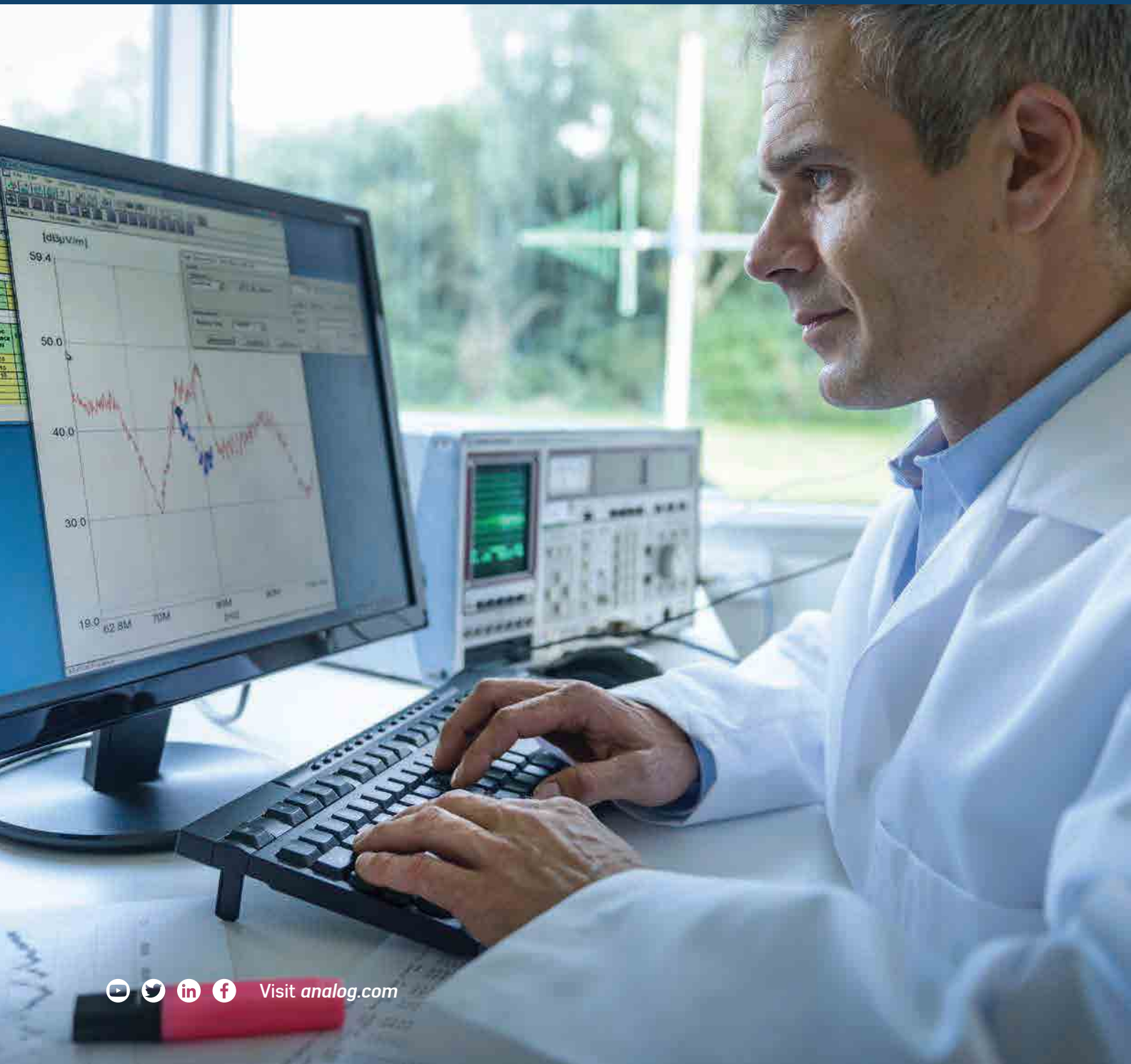



Authorised Analog Devices Distributor and Highly Qualified Test and Programming House



PROGRAMMIERSERVICE

PROGRAMMING SERVICE

- Programming
- Marking (Lasers, labels, colour-coding)
- Taping



WARENEINGANG

INCOMING GOODS INSPECTION

Logistic requirements

- Consignment warehouse
- Ship to stock
- Just in Time
- Kanban



LEISTUNGEN TESTHAUS

TEST HOUSE SERVICES

Semitron Test House Services

- Optical / visual inspections
- Authentication
- Component testing
- Selections
- Heat treatment
- Component analysis
- Component programming
- Mechanical processing
- Tape & reel service
- Scanning and straightening of component connection pins
- Dry packing



TESTANLAGEN

TEST SYSTEMS

- Data sheet checks
- Selection
- Thermal tests
- Fully-automated handling



GURTUNGS SERVICE

TAPE AND REEL SERVICE

Taping Options

- Axial components (DIN IEC-286-1), diodes, resistors, capacitors
- Radial components (DIN IEC-286-2), ELKOs, LEDs, transistors, etc.
- SMD taping (EIA-481-1A), SOIC, PLCC, TSOP, SSOP, QFP, etc.

Contents

A 2019 Letter from ADI's Precision Technology Group's Management	4	Muxed Input SAR ADCs	70	High Temperature	96
Introduction	5	Wideband Oversampled ADCs (FIR Filter)	70	Temperature Sensors	97
New Products	6	Narrow-Band Oversampling ADCs	71	Analog Output	98
Operational Amplifiers (Op Amps)	6	Precision DACs	72	Digital Output	98
ADC Drivers/Differential Amplifiers	7	Voltage Output (V_{OUT}) DACs	72	Trip Point	99
Difference Amplifiers	7	Single-Channel to 8-Channel, Low Voltage Single-Supply V_{OUT} DACs	72	Integrated Digital Output with DACs/ADCs/Both	99
Current Sense Amplifiers	7	Single-Channel to 8-Channel, Bipolar Voltage Output DACs	73	Fan Controllers	99
Precision ADCs	8	16-Channel to 40-Channel Voltage Output DACs	75	Sensor Interface Signal Chain Solutions	100
Precision DACs	8	Parallel Interface Voltage Output DACs	75	Battery Formation and Testing	100
Voltage References	8	Multiplying (I_{OUT}) DACs	77	Biopotential Sensing	100
Switches and Multiplexers	10	Special Function DACs	77	Current Sensing—Medium Voltage Rail Shunts	101
Temperature Sensors	11	4 mA to 20 mA Loop DACs	77	Current Sensing—High Voltage Rail Shunts	101
Operational Amplifiers (Op Amps)	12	High Voltage DACs	78	Current Sensing—Contactless Current Measurement	102
Precision ($V_{OS} < 1$ mV and $TCV_{OS} < 2$ μ V/ $^{\circ}$ C) Amplifiers	12	Fast Precision DACs (>30 MSPS)	78	Position Sensing—Optical Encoders	102
Zero-Drift Amplifiers	18	Micropower Voltage Output DACs	78	Position Sensing—Resolver and LVDT	103
Low Noise ($V_{NOISE} \leq 5$ nV/ \sqrt{Hz}) Amplifiers	20	Current Source-Sink DACs	78	Position Sensing—AMR and TMR	103
Low Power ($I_Q/Amp < 0.5$ mA) Amplifiers	25	ADC/DAC Combos	79	Temperature Sensing—Thermocouples (TC)	104
Low Input Bias Current ($I_{BIAS} < 75$ pA) Amplifiers	28	PWM to Voltage Output DACs	79	Temperature Sensing—Resistive Thermal Devices (RTD)	105
Overvoltage Protection/Over-the-Top (OVP/OTT) Amplifiers	32	Digital Potentiometers	80	Temperature Sensing—Thermistors	106
High Voltage ($V \geq 30$ V) Precision Amplifiers	33	Nonvolatile Memory	80	Temperature Sensing—Diodes	107
High Voltage ($V \geq 30$ V), High Speed Amplifiers	37	Volatile Digital Potentiometers	81	Temperature Sensing—Silicon Sensors	108
High Speed ($BW \geq 50$ MHz) Amplifiers	39	Voltage References	82	Chemical Analysis—Spectroscopy	108
High Speed ($BW \geq 50$ MHz), Low Noise Amplifiers	42	High Stability Voltage References	82	Chemical Analysis—Charged Particle Beams	110
High Output Current ($I_{OUT} \geq 100$ mA) Amplifiers	44	Automotive Qualified References	84	Chemical Analysis—Electrochemical Cell	111
ADC Drivers/Differential Amplifiers	47	High Output Current References	86	Chemical Analysis—Ion Selective Electrodes (pH)	112
Instrumentation Amplifiers	52	Standard REF—Series Mode	86	Amplifier and Precision Converter Design Tools	113
Difference Amplifiers	54	Standard REF—Shunt Mode	88	LTspice	113
Current Sense Amplifiers	55	Switches and Multiplexers	90	Precision ADC Driver Tool	113
Filters	56	0 Hz/DC to RF Performance, MEMS Switches with Integrated Driver	91	Analog Filter Wizard	113
Comparators	57	SPI+ Interface with Digital Error Detection	91	Analog Photodiode Wizard	113
Precision ADCs	61	Overvoltage Detection and Protection: –55 V OVP to +55 V OVP	91	Power Dissipation vs. Die Temperature	113
Single-Channel SAR ADCs	62	Channel Overvoltage Detection and Protection: –55 V OVP to +55 V OVP	91	In-Amp Diamond Plot Tool	113
μ Module Data Acquisition Systems	63	Overvoltage Detection and Protection: –60 V OVP to +60 V OVP	92	ADI DiffAmpCalc	114
Simultaneous Sampling ADCs (High Resolution)	67	Channel Overvoltage Protection: –40 V OVP to +40 V OVP	92	Difference Amplifier Tools	114
Simultaneous Sampling ADCs	69	Overvoltage Protection: –5.5 V OVP to +16 V OVP	93	SNR/THD/SINAD Calculator	114
Isolated Σ - Δ Modulators	69	± 15 V Latch-Up Immune and High ESD ± 15 V Analog	93	Σ - Δ ADC Tutorial	114
		± 5 V Analog	94	LinearLabTools	114
		Low Voltage DC to High Frequency RF	94	Analysis Control Evaluation (ACE) Software	114
		Unbuffered Analog Crosspoint Arrays	95	Virtual Eval BETA	115
		Bus Switches	95	Circuits from the Lab Reference Designs	115
		Level Translators	95	EngineerZone	115
		<5.5 V Analog	95		

A 2019 Letter from ADI's Precision Technology Group's Management

Thank you again for choosing Analog Devices as your precision technology partner.

As our industry, and indeed world, transforms at an unprecedented rate, change poses both opportunities and challenges for Analog Devices and, more importantly, our valued customers. The evolution of Analog Devices over the past 50+ years has been based on innovation, customer partnerships, and a continuous improvement mindset to lead the industry in bridging the physical and digital worlds in an ever-changing landscape—a charter that has and continues to be at the forefront of the Precision Technology Group.



Supporting the Complete High Performance Precision Signal Chain Solutions in a Changing World

In today's world, we are experiencing unprecedented simultaneous change in almost every market segment from instrumentation, to industrial to healthcare, communications, data center, automotive, consumer, energy, security, IoT, and so on, which, coupled with the underlying megatrend for ubiquitous sensing, is driving unparalleled demand for precision technology. More importantly, it is a driving customer desire for a single source, easy to use, performance-focused precision technology solutions partner that can not only solve real-time customer challenges with complete precision signal chain solutions, but also accelerate customer time to market and agility to maximize success. Analog Devices' performance precision technology continues to enable our customers lead in addressing both legacy and ever-increasing new challenges as our world continues to evolve.

Through this latest 2019 revision of our Precision Technology Selection Guide, we are also pleased to provide customers with a wider, more complete portfolio of high performance signal chain solutions across different modalities, and while this is only a selection of the precision technology signal chain solutions available through partnering with Analog Devices, this guide nevertheless demonstrates the increasing value Analog Devices' precision technology provides to address the complete precision performance solution challenges of our global customer base.

Analog Devices and Linear Technology's Combined Product Development Expertise

With Analog Devices and Linear Technology now one company, and with a combined product portfolio of over 15,000 commercially available precision product offerings encompassing precision converters (ADCs and DACs), amplifiers, multipliers and dividers, comparators, precision modulators/demodulators, sensors, references, switches, and multiplexers, Analog Devices continues to lead the global high performance precision solutions market—and our product offering continues to grow. We have created this combined precision signal chain selection guide to give you quick and easy access to information on our latest industry leading high performance products so you can find the best and newest parts for your complete signal chain designs. Due to the breadth of our product portfolio, we unfortunately cannot include every precision product available from Analog Devices in this publication, but please ensure you visit us at analog.com should you wish to explore every available product and/or if your preferred part is not contained in this guide.

Easy Access to New Products

We have also included a “New Product List” and featured product pages to highlight recently released and noteworthy parts for your designs, as well as parts to be released in the near future, to ensure the most up-to-date information is available to you for consideration for upcoming designs.

Tools and Support

In order to simplify the overall design process, our high performance precision products are complemented with a range of design and development resources, including free design tools, rapid prototyping platforms, Circuits from the Lab[®] reference designs, and EngineerZone[®] technical forums.

These are exciting times both in the industry and at Analog Devices. We are glad to have the opportunity to provide innovative technical solutions to help you address your product development challenges and facilitate your delivery of differentiated end-market solutions with Analog Devices' complete signal chain solutions.

Sincerely,

A handwritten signature in black ink, appearing to read "Leo McHugh".

Leo McHugh
Vice President,
Precision Technology Group

Introduction

Precision Signal Chain Solutions

With the broadest portfolio of op amps, precision converters (ADCs and DACs), digital potentiometers, temperature sensors, voltage references, switches, and multiplexers, Analog Devices can help solve your toughest design challenges. Whether you're working on a solution for test and measurement, industrial automation, automotive, healthcare, aerospace and defense, communications, and other applications, Analog Devices offers over 15,000 precision linear ICs to meet your design needs. This comprehensive product line is backed by outstanding customer support and a full complement of precision design and development resources, including free design tools, Circuits from the Lab reference designs, and EngineerZone technical forums.

Precision Is Tomorrow's World

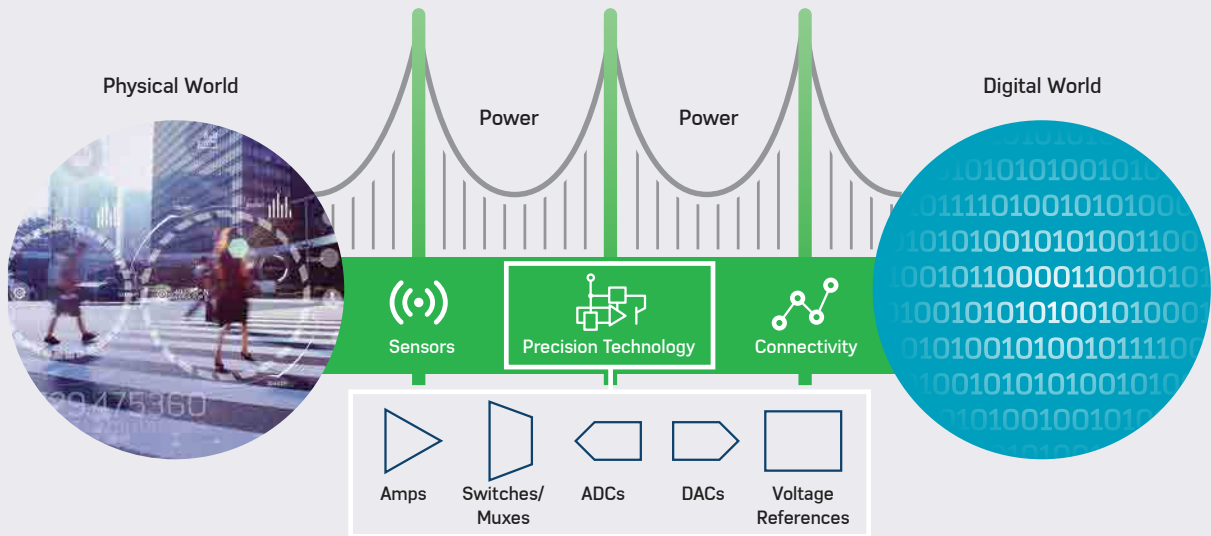

Bridging the physical and digital worlds

Analog Devices' precision solutions are used in any application in any vertical market segment that has a requirement to measure and protect, condition and acquire, or synthesize and drive.



Instrumentation



Healthcare



Consumer

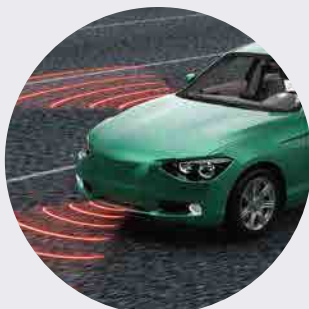

Automotive



Energy and Industrial



Aerospace and Defense



Communications

New Products

Operational Amplifiers (Op Amps)

Precision ($V_{os} < 1\text{ mV}$ and $TCV_{os} < 2\ \mu\text{V}/^\circ\text{C}$) Amplifiers

Part Number	Number of Amps	V_{os} (max) (μV)	V_{os} TC (typ) ($\mu\text{V}/^\circ\text{C}$)	I_{BIAS} (max) (nA)	GBP (typ) (MHz)	Slew Rate (typ) (V/ μs)	V_{NOISE} Density (typ) (nV/ $\sqrt{\text{Hz}}$)	0.1 Hz to 10 Hz V_{NOISE} (typ) (μV p-p)	I_o/Amp (typ) (mA)	V_s Span (min) (V)	V_s Span (max) (V)	Package	ECCN Code
ADA4625-1	1	80	0.2	0.075	18	48	3.3	0.15	4	5	36	8-lead SOIC-EP	EAR99
LT1997-2	1	80	0.5	5	1	0.75	37	0.9	0.35	3.3	50	16-lead MSOP (4 pins removed), 14-lead DFN	EAR99
LTC6260	4	400	1.5	75	1.3	0.24	38	2	0.02	1.8	5.25	10-lead MSOP	EAR99

Zero-Drift Amplifiers

Part Number	Number of Amps	V_{os} (max) (μV)	V_{os} TC (max) ($\mu\text{V}/^\circ\text{C}$)	I_{BIAS} (max) (pA)	GBP (typ) (MHz)	Slew Rate (typ) (V/ μs)	V_{NOISE} Density (typ) (nV/ $\sqrt{\text{Hz}}$)	0.1 Hz to 10 Hz V_{NOISE} (typ) (μV p-p)	I_o/Amp (typ) (mA)	V_s Span (min) (V)	V_s Span (max) (V)	Package	ECCN Code
LTC2064	2	5	0.02	20	0.02	0.004	220	4.6	0.001	1.7	5.25	8-lead MSOP, 10-lead DFN	EAR99
LTC2066	1	5	0.02	35	0.1	0.018	80	1.7	0.008	1.7	5.25	5-lead SOT-23, 6-lead SC70	EAR99
LTC2067	2	5	0.02	35	0.1	0.018	80	1.7	0.008	1.7	5.25	8-lead MSOP, 10-lead DFN	EAR99
LTC2058	2	5	0.025	100	2.5	1.6	9	0.2	0.95	4.75	36	12-lead MSOP-EP, 8-lead SOIC-EP	EAR99

Low Noise ($V_{NOISE} \leq 5\text{ nV}/\sqrt{\text{Hz}}$) Amplifiers

Part Number	Number of Amps	V_{NOISE} Density (typ) (nV/ $\sqrt{\text{Hz}}$)	0.1 Hz to 10 Hz V_{NOISE} (typ) (μV p-p)	V_s Span (min) (V)	V_s Span (max) (V)	I_o/Amp (typ) (mA)	V_{os} (max) (μV)	V_{os} TC (max) ($\mu\text{V}/^\circ\text{C}$)	I_{BIAS} (max) (nA)	GBP (typ) (MHz)	Slew Rate (typ) (V/ μs)	Package	ECCN Code
ADA4625-1	1	3.3	0.15	5	36	4	80	2.1	0.075	18	48	8-lead SOIC-EP	EAR99
LTC2058	2	9	0.2	4.75	36	0.95	5	0.025	0.1	2.5	1.6	12-lead MSOP-EP, 8-lead SOIC-EP	EAR99
LT6274	1	10	1	9	32	1.6	400	10	500	40	2200	5-lead SOT-23	EAR99

Low Power ($I_o/\text{Amp} < 0.5\text{ mA}$) Amplifiers

Part Number	Number of Amps	I_o/Amp (typ) (μA)	Shut-down	GBP (typ) (MHz)	Slew Rate (typ) (V/ μs)	I_{BIAS} (max) (nA)	V_{os} (max) (μV)	V_{NOISE} Density (typ) (nV/ $\sqrt{\text{Hz}}$)	0.1 Hz to 10 Hz V_{NOISE} (typ) (μV p-p)	V_s Span (min) (V)	V_s Span (max) (V)	Package	ECCN Code
LTC2064	2	1.4	Yes	0.02	0.004	0.02	5	220	4.6	1.7	5.25	8-lead MSOP, 10-lead DFN	EAR99
LTC2066	1	7.5	Yes	0.1	0.018	0.035	5	80	1.7	1.7	5.25	5-lead SOT-23, 6-lead SC70	EAR99
LTC2067	2	7.5	Yes	0.1	0.018	0.035	5	80	1.7	1.7	5.25	8-lead MSOP, 10-lead DFN	EAR99
LTC6260	4	20	No	14.3	0.24	75	400	38	2	1.8	5.25	10-lead MSOP	EAR99
LT1997-2	1	350	Yes	11	0.75	5	80	37	0.9	3.3	50	16-lead MSOP (4 pins removed), 14-lead DFN	EAR99

Low Input Bias Current ($I_{BIAS} < 75\text{ pA}$) Amplifiers

Part Number	Number of Amps	I_{BIAS} (max) (pA)	V_{os} (max) (μV)	V_{os} TC (max) ($\mu\text{V}/^\circ\text{C}$)	V_{NOISE} Density (typ) (nV/ $\sqrt{\text{Hz}}$)	0.1 Hz to 10 Hz V_{NOISE} (typ) (μV p-p)	GBP (typ) (MHz)	Slew Rate (typ) (V/ μs)	I_o/Amp (typ) (mA)	V_s Span (min) (V)	V_s Span (max) (V)	Package	ECCN Code
LTC2064	2	20	5	0.02	220	4.6	0.02	0.004	0.001	1.7	5.25	8-lead MSOP, 10-lead DFN	EAR99
LTC2066	1	35	5	0.02	80	1.7	0.1	0.018	0.008	1.7	5.25	5-lead SOT-23, 6-lead SC70	EAR99
LTC2067	2	35	5	0.02	80	1.7	0.1	0.018	0.008	1.7	5.25	8-lead MSOP, 10-lead DFN	EAR99
ADA4625-1	1	75	80	2.1	3.3	0.15	18	48	4	5	36	8-lead SOIC-EP	EAR99
LTC2058	2	100	5	0.025	9	0.2	2.5	1.6	0.95	4.75	36	12-lead MSOP-EP, 8-lead SOIC-EP	EAR99

New Products

Overvoltage Protection/Over-the-Top (OVP/OTT) Amplifiers

Part Number	Number of Amps	Overvoltage Protection/Over-the-Top	Rail to Rail	V _s Span (min) (V)	V _s Span (max) (V)	V _{os} (max) (μV)	V _{os} TC (max) (μV/°C)	I _{BIAS} (max) (nA)	GBP (typ) (MHz)	Slew Rate (typ) (V/μs)	V _{NOISE} Density (typ) (nV/√Hz)	0.1 Hz to 10 Hz V _{NOISE} (typ) (μV p-p)	I _o /Amp (typ) (mA)	Package	ECCN Code
LT1997-2	1	OTT	Both	3.3	50	80	1.5	55	1	0.75	37	0.9	3.85	16-lead MSOP (4 pins removed), 14-lead DFN	EAR99

High Voltage (V ≥ 30 V) Precision Amplifiers

Part Number	Number of Amps	V _s Span (min) (V)	V _s Span (max) (V)	I _o /Amp (typ) (mA)	V _{os} (max) (μV)	V _{os} TC (max) (μV/°C)	I _{BIAS} (max) (nA)	V _{NOISE} Density (typ) (nV/√Hz)	0.1 Hz to 10 Hz V _{NOISE} (typ) (μV p-p)	GBP (typ) (MHz)	Slew Rate (typ) (V/μs)	Package	ECCN Code
LT1997-2	1	3.3	50	0.35	80	1.5	5	37	0.9	1	0.75	16-lead MSOP (4 pins removed), 14-lead DFN	EAR99
LTC2058	2	4.75	36	0.95	5	0.025	0.1	9	0.2	2.5	1.6	12-lead MSOP-EP, 8-lead SOIC-EP	EAR99
ADA4625-1	1	5	36	4	80	2.1	0.075	3.3	0.15	18	48	8-lead SOIC-EP	EAR99
LT6274	1	9	32	1.6	400	10	500	10	1	40	2200	5-lead SOT-23	EAR99

High Speed (BW ≥ 50 MHz) Amplifiers

Part Number	Number of Amps	GBP (typ) (MHz)	Slew Rate (typ) (V/μs)	I _{BIAS} (typ) (nA)	V _{os} (typ) (μV)	V _{NOISE} Density (typ) (nV/√Hz)	I _o /Amp (typ) (mA)	V _s Span (min) (V)	V _s Span (max) (V)	Package	ECCN Code
LT6274	1	40	2200	100	150	10	1.6	9	32	5-lead SOT-23	EAR99

High Speed (BW ≥ 50 MHz), Low Noise Amplifiers

Part Number	Number of Amps	GBP (typ) (MHz)	Slew Rate (typ) (V/μs)	I _{BIAS} (typ) (nA)	V _{os} (typ) (μV)	V _{NOISE} Density (typ) (nV/√Hz)	I _o /Amp (typ) (mA)	V _s Span (min) (V)	V _s Span (max) (V)	Package	ECCN Code
LT6274	1	40	2200	100	150	10	1.6	9	32	5-lead SOT-23	EAR99

ADC Drivers/Differential Amplifiers

Part Number	Number of Channels	BW -3 dB (typ) (MHz)	Gain Set	Gain (min) (dB)	Gain (max) (dB)	V _{NOISE} Density (typ) (nV/√Hz)	Distortion 2 nd Harmonic (typ) (dBc)	Distortion 3 rd Harmonic (typ) (dBc)	I _s (typ) (mA)	V _s Span (min) (V)	V _s Span (max) (V)	Input type	Package	ECCN Code
ADA4945-1	1	200	Resistor			6.2	-140	-148	4	2.7	11	Differential	16-lead LFCSP (1.6 mm EP)	EAR99

Difference Amplifiers

Part Number	Number of Amps	Common-Mode In (min) (V)	Common-Mode In (max) (V)	Gain (min) (V/V)	Gain (max) (V/V)	BW—Low Gain (typ) (MHz)	Slew Rate (typ) (V/μs)	I _o /Amp (max) (mA)	V _s Span (min) (V)	V _s Span (max) (V)	Input Beyond Supply	Package	ECCN Code
LT1997-2	1	-255	255	0.1	0.25	1	0.75	0.4	3.3	50	Yes	16-lead MSOP (4 pins removed), 14-lead DFN	EAR99
LT1990-10	1	-250	250	10	10	0.1	0.4	0.18	2.4	36	No	SOIC, 150 mil 8-lead MSOP	EAR99
LT6376	1	-230	230	10	10	0.16	4.1	0.4	3.3	50	Yes	16-lead MSOP (4 pins removed), 14-lead DFN	EAR99

Current Sense Amplifiers

Part Number	Common-Mode In (min) (V)	Common-Mode In (max) (V)	V _{os} (max) (mV)	Gain (V/V)	BW -3 dB (typ) (MHz)	V _s Span (min) (V)	V _s Span (max) (V)	V _{in} Direction	Filter Option	Automotive	Package	ECCN Code
LTC6115	5	100	0.5	Resistor set	0.5	5	100	Unidirectional	No	Yes	12-lead MSOP	EAR99

New Products

Precision ADCs

µModule Data Acquisition Systems

Resolution	Input Type	Max Output Data Rate		
		≤500 kSPS	≤1 MSPS	≤2 MSPS
18-bit	Fully differential			■ ADAQ4003

Simultaneous Sampling ADCs (High Resolution)

Input Type	Channels	≤200 kSPS/Channel	≤400 kSPS/Channel	≤700 kSPS/Channel	≤1 MSPS/Channel	≤2 MSPS/Channel	≤5 MSPS/Channel
<i>24-Bit</i>							
Fully differential/ single-ended	16	■ AD4111 ■ AD4112					
<i>16-Bit</i>							
Fully differential	2				■ AD7903		■ AD7380

Simultaneous Sampling ADCs

Input Type	Channels	<150 kSPS/Channel	≤400 kSPS/Channel	≤1 MSPS/Channel	≤2 MSPS/Channel	≤5 MSPS/Channel
<i>14-Bit</i>						
Fully differential	2			■ AD7264*		■ AD7381

Isolated Σ-Δ Modulators

Channels	Interface	Integrated	Isolated Working Voltage		
			400 V rms	750 V rms Reinforced	884 V rms
1	CMOS			■ ADuM7701 ■ ADuM7701-8	

Precision DACs

Current Source-Sink DACs

Resolution	Interface	Channels	Current Sink		Part Number	Current Source	
			Part Number	Output Range			Output Ranges
16-Bit	SPI	5	■ LTC2662-16		■ LTC2652-16	Software selectable all channels: 3.125 mA, 6.25 mA, 12.5 mA, 25 mA, 50 mA, 100 mA, 200 mA, 300 mA	
			■ AD5770R				Software selectable all channels: 3.125 mA, 6.25 mA, 12.5 mA, 25 mA, 50 mA, 100 mA, 200 mA, 300 mA, and a switch to V_{SS} to sink current
			■ LTC2662-12				
12-Bit	SPI	5					

Voltage References

High Stability Voltage References

Part Number	Output Voltage (V)	Tempco (ppm/°C) (max)	Initial Accuracy (%) (max)	Supply Voltage Range (V)	ISY (Max)	Output Current Source/Sink (mA)	0.1 Hz to 10 Hz Noise		Temperature Range (°C)	Type	Package	ECCN Code
							µV p-p	ppm p-p				
ADR4525	2.5	1	0.02, 0.04	3.0 to 15	950 µA	-10 to +10	1.25	0.6	0°C to 70°C	Series	SOIC	EAR99
LT6657	1.25, 2.048, 2.5, 3, 3.3, 4.096, 5	1.5, 3	0.1	1.3 to 40	1.2 mA	±10		0.5	-40°C to +125°C	Series	8-lead MSOP	EAR99
LTC6655LN	1.25, 2.048, 2.5, 3, 3.3, 4.096, 5	2, 5	0.025, 0.05	3.0 to 13.2	5 mA	±10		0.25	-40°C to +125°C	Series	8-lead MSOP, 8-lead LS	EAR99

New Products

Automotive Qualified References

Part Number	Output Voltage (V)	Initial Accuracy (%) (Max)	Supply Voltage Range (V)	ISY (max)	Tempco (ppm/°C) (max)	Output Current Source/Sink (mA)	0.1 Hz to 10 Hz Noise		Temperature Range (°C)	Type	Package	ECCN Code
							μV p-p	ppm p-p				
LT6657	1.25, 2.048, 2.5, 3, 3.3, 4.096, 5	0.1	1.3 to 40	1.2 mA	1.5, 3	±10		0.5	-40°C to +125°C	Series	MS-8	EAR99
ADR4525	2.5	0.02	3.0 to 15	950 μA	2	-10 to +10	1.25	0.6	-40°C to +125°C	Series	SOIC	EAR99
ADR3512	1.2	0.1	2.3 to 5.5	100 μA	4, 8	-3 to +10	8	6.7	-40°C to +125°C	Series	MSOP	EAR99
ADR3525	2.5	0.1	2.7 to 5.5	100 μA	5, 8	-3 to +10	18	7.2	-40°C to +125°C	Series	MSOP	EAR99
ADR3530	3	0.1	3.2 to 5.5	100 μA	5, 8	-3 to +10	22	7.3	-40°C to +125°C	Series	MSOP	EAR99
ADR3533	3.3	0.1	3.5 to 5.5	100 μA	5, 8	-3 to +10	25	7.6	-40°C to +125°C	Series	MSOP	EAR99
ADR3540	4.096	0.1	4.3 to 5.5	100 μA	5, 8	-3 to +10	29	7.1	-40°C to +125°C	Series	MSOP	EAR99
ADR3550	5	0.1	5.2 to 5.5	100 μA	5, 8	-3 to +10	35	7.0	-40°C to +125°C	Series	MSOP	EAR99
ADR365 (H-grade)	5	0.16	5.3 to 15	190 μA	25	-1 to +5	12.8	2.6	-40°C to +150°C	Series	SOT-23	EAR99
LT6654	1.25, 2.048, 2.5, 3, 3.3, 4.096, 5	0.05, 0.1	1.75 to 36	350 μA	10, 20	±10		1.6	-40°C to +125°C	Series	SOT-23	EAR99
ADR5041	2.5	0.1, 0.2			75, 100		19.2	7.7	-40°C to +125°C	Shunt	SOT-23	EAR99
ADR5044	4.096	0.1, 0.2			75, 100		32.2	7.9	-40°C to +125°C	Shunt	SOT-23	EAR99

High Output Current References

Part Number	Output Voltage (V)	Initial Accuracy (%) (max)	Supply Voltage Range (V)	ISY (max)	Tempco (ppm/°C) (max)	Output Current Source/Sink (mA)	0.1 Hz to 10 Hz Noise		Temperature Range (°C)	Type	Package	ECCN Code
							μV p-p	ppm p-p				
LT6658	1.2, 1.8, 2.5, 3, 3.3, 5	0.05, 0.1	5 to 36	2 mA	10, 20	+150/-20		1.6	-40°C to +125°C	Series	16-lead DFN, 16-lead MSOP-EP	EAR99

Standard REF—Series Mode

Part Number	Output Voltage (V)	Initial Accuracy (%) (max)	Supply Voltage Range (V)	ISY (max)	Tempco (ppm/°C) (max)	Output Current Source/Sink (mA)	0.1 Hz to 10 Hz Noise		Temperature Range (°C)	Type	Package	ECCN Code
							μV p-p	ppm p-p				
LT6657	1.25, 2.048, 2.5, 3, 3.3, 4.096, 5	0.1	1.3 to 40	1.2 mA	1.5, 3	±10		0.5	-40°C to +125°C	Series	8-lead MSOP	EAR99
LTC6655	1.25, 2.048, 2.5, 3, 3.3, 4.096, 5	0.025, 0.05	3.0 to 13.2	5 mA	2, 5	±10		0.25	-40°C to +125°C	Series	8-lead MSOP	EAR99
ADR3512W	1.2	0.1	2.3 to 5.5	100 μA	4, 8	-3 to +10	8	6.7	-40°C to +125°C	Series	MSOP	EAR99
ADR3525W	2.5	0.1	2.7 to 5.5	100 μA	5, 8	-3 to +10	18	7.2	-40°C to +125°C	Series	MSOP	EAR99
ADR3530W	3	0.1	3.2 to 5.5	100 μA	5, 8	-3 to +10	22	7.3	-40°C to +125°C	Series	MSOP	EAR99
ADR3533W	3.3	0.1	3.5 to 5.5	100 μA	5, 8	-3 to +10	25	7.6	-40°C to +125°C	Series	MSOP	EAR99
ADR3540W	4.096	0.1	4.3 to 5.5	100 μA	5, 8	-3 to +10	29	7.1	-40°C to +125°C	Series	MSOP	EAR99
ADR3550W	5	0.1	5.2 to 5.5	100 μA	5, 8	-3 to +10	35	7.0	-40°C to +125°C	Series	MSOP	EAR99
ADR3412	1.2	0.1	2.3 to 5.5	100 μA	8	-3 to +10	8	6.7	-40°C to +125°C	Series	SOT-23	EAR99
ADR3420	2.048	0.1	2.3 to 5.5	100 μA	8	-3 to +10	15	7.3	-40°C to +125°C	Series	SOT-23	EAR99
ADR3425	2.5	0.1	2.7 to 5.5	100 μA	8	-3 to +10	18	7.2	-40°C to +125°C	Series	SOT-23	EAR99
ADR3430	3	0.1	3.2 to 5.5	100 μA	8	-3 to +10	22	7.3	-40°C to +125°C	Series	SOT-23	EAR99
ADR3433	3.3	0.1	3.5 to 5.5	100 μA	8	-3 to +10	25	7.6	-40°C to +125°C	Series	SOT-23	EAR99
ADR3440	4.096	0.1	4.3 to 5.5	100 μA	8	-3 to +10	29	7.1	-40°C to +125°C	Series	SOT-23	EAR99
ADR3450	5	0.1	5.2 to 5.5	100 μA	8	-3 to +10	35	7.0	-40°C to +125°C	Series	SOT-23	EAR99
LT6654	1.25, 2.048, 2.5, 3, 3.3, 4.096, 5	0.05, 0.1	1.75 to 36	350 μA	10, 20	±10		1.6	-55°C to +125°C	Series	SOT-23	EAR99
LT6658	1.2, 1.8, 2.5, 3, 3.3, 5	0.05, 0.1	5 to 36	2 mA	10, 20	+150/-20		1.6	-40°C to +125°C	Series	16-lead MSE	EAR99

New Products

Standard REF—Shunt Mode

Part Number	Output Voltage (V)	Initial Accuracy (%)	Current Range		Tempco (ppm/°C) (max)	Output Impedance (Ω)	0.1 Hz to 10 Hz Noise		Temperature Range (°C)	Type	Package	ECCN Code
			Min	Max (mA)			μV p-p	ppm p-p				
LT6657	1.25, 2.048, 2.5, 3, 3.3, 4.096, 5	0.1	2.5 mA	11	1.5, 3			0.5	-40°C to +125°C	Shunt	8-lead MSOP	EAR99
ADR5040	2.048	0.1, 0.2	50 μA	15	75, 100	0.2	16.8	8.2	-40°C to +125°C	Shunt	SC70, SOT-23	EAR99
ADR5041	2.5	0.1, 0.2	50 μA	15	75, 100	0.2	19.2	7.7	-40°C to +125°C	Shunt	SC70, SOT-23	EAR99
ADR5043	3	0.1, 0.2	50 μA	15	75, 100	0.2	25.8	8.6	-40°C to +125°C	Shunt	SC70, SOT-23	EAR99
ADR5044	4.096	0.1, 0.2	50 μA	15	75, 100	0.2	32.2	7.9	-40°C to +125°C	Shunt	SC70, SOT-23	EAR99
ADR5045	5	0.1, 0.2	50 μA	15	75, 100	0.2	39.6	7.9	-40°C to +125°C	Shunt	SC70, SOT-23	EAR99

Switches and Multiplexers

0 Hz/DC to RF Performance, MEMS Switches with Integrated Driver

Part Number	Configuration	Specifications									Interface	HBM ESD Level—RF Pins (kV)	Package	ECCN Code
		R _{ON} (Ω) (typ)	Off Leakage (nA) (typ)	Frequency Response (Hz) (min)	Frequency Response (GHz) (max)	Insertion Loss (dB) (typ)	Off Isolation (dB) (typ)	IIP3 (dBm) (typ)	Input Power (dBm) (max)	Specified at Frequency (GHz)				
ADGM1304	(4:1) × 1	1.6	0.5	0	14	0.26	24	69	36	2.5	Parallel	0.1	LFCSP	EAR99
ADGM1004	(4:1) × 1	1.8	0.5	0	13	0.45	24	67	32	2.5	Parallel	5	LFCSP	EAR99

SPI+ Interface with Digital Error Detection

Part Number	Configuration	Specifications				Characterization Voltages (V _{NOM})						Interface	Package	ECCN Code	
		R _{ON} (Ω) (typ)	On Leakage (nA) (typ)	Q _{MU} (pC) (typ)	BW (MHz)	Single				Dual					
						3.3	5	12	36	±5	±15				±20
ADGS1412	SPST × 4	1.5	0.15	20	170		•	•		•	•		SPI+	LFCSP	EAR99
ADGS5412	SPST × 4	9.8	0.1	245	167			•	•		•	•	SPI+	LFCSP	EAR99
ADGS1212	SPST × 4	120	0.02	0.9	1000			•			•		SPI+	LFCSP	EAR99
ADGS1612	SPST × 4	1	0.2	120	34		•	•			•		SPI+	LFCSP	EAR99
ADGS5414	SPST × 8	13.5	0.15	125	200			•	•		•	•	SPI+	LFCSP	EAR99
ADGS1208/ADGS1209	8:1 diff, 4:1 mux	120	0.02	0.4	550						•		SPI+	LFCSP	EAR99
ADGS1408/ADGS1409	8:1 diff, 4:1 mux	4	0.1	50	60			•	•		•	•	SPI+	LFCSP	EAR99

SPI+: SPI device, which has multiple modes of operation.

Overvoltage Detection and Protection: -55 V OVP to +55 V OVP

Part Number	Configuration	HBM ESD Level (kV)	Specifications					Characterization Voltages (V _{NOM})				Interface	Package	ECCN Code
			R _{ON} (Ω) (typ)	R _{ON} Flatness (Ω)	On Leakage (nA) (typ)	Q _{MU} (pC) (typ)	BW (MHz)	Single		Dual				
								12	36	±15	±20			
ADG5436F	SPDT × 2	6	10	0.6	0.3	654	108	•	•	•	•	Parallel	TSSOP, LFCSP	EAR99
ADG5243F	SPDT × 3	3.5	270	7	0.3	0.8	350	•	•	•	•	Parallel	TSSOP, LFCSP	EAR99
ADG5208F/ADG5209F	8:1 diff, 4:1 mux	3.5	250	6.5	0.3	0.4	190/290	•	•	•	•	Parallel	TSSOP, LFCSP	EAR99
ADG5248F/ADG5249F	8:1 diff, 4:1 mux	3.5	250	6.5	0.3	0.8	190/320	•	•	•	•	Parallel	TSSOP, LFCSP	EAR99

High Temperature

Part Number	Configuration	Temperature Range	Specifications				Characterization Voltages (V _{NOM})						Interface	Package	ECCN Code	
			R _{ON} (Ω) (max)	On Leakage (nA) (max)	Q _{MU} (pC)	BW (MHz)	Single				Dual					
							3	5	12	36	±2.5	±15				±20
ADG798	8:1 mux	-55°C to +210°C	10	2600	3	55	•	•			•		Parallel	Ceramic flatpack, ceramic flatpack RFG	EAR99	
ADG5298	8:1 mux	-55°C to +210°C	400	70	0.2	110			•	•		•	•	Parallel	Ceramic flatpack, ceramic flatpack RFG	EAR99

New Products

Temperature Sensors

Analog Output

Part Number	Interface	Function/Resolution	Max Accuracy	Operating Range (°C)	Supply Range (V)	Max Current	Packages	Features	ECCN Code
ADT5912	Voltage output	10 mV/K	±0.1°C @ -20°C to +90°C	-40 to +125	-4.75 to +5.2	-2 mA	4-lead LFCSP	2-terminal temperature transducer	EAR99

Digital Output

Part Number	Interface	Function/Resolution	Max Accuracy	Operating Range (°C)	Supply Range (V)	Max Current	Packages	Features	ECCN Code
ADT7422	I ² C/SMBus	16-bit local	±0.1°C @ 37°C to 39°C	-40 to +150	2.7 to 5.5	270 µA	16-lead LFCSP	16-bit digital temperature sensor, critical temperature indicator, programmable interrupt	EAR99

Operational Amplifiers (Op Amps)

Precision ($V_{os} < 1 \text{ mV}$ and $TCV_{os} < 2 \mu\text{V}/^\circ\text{C}$) Amplifiers

Part Number	Number of Amps	V_{os} (max) (μV)	V_{os} TC (typ) ($\mu\text{V}/^\circ\text{C}$)	I_{BIAS} (max) (nA)	GBP (typ) (MHz)	Slew Rate (typ) ($\text{V}/\mu\text{s}$)	V_{NOISE} Density (typ) ($\text{nV}/\sqrt{\text{Hz}}$)	0.1 Hz to 10 Hz V_{NOISE} (typ) ($\mu\text{V p-p}$)	I_o /Amp (typ) (mA)	V_s Span (min) (V)	V_s Span (max) (V)	Package	ECCN Code
ADA4625-1 <i>New</i>	1	80	0.2	0.075	18	48	3.3	0.15	4	5	36	8-lead SOIC-EP	EAR99
LT1997-2 <i>New</i>	1	80	0.5	5	1	0.75	37	0.9	0.35	3.3	50	16-lead MSOP (4 pins removed), 14-lead DFN	EAR99
LTC6260 <i>New</i>	4	400	1.5	75	1.3	0.24	38	2	0.02	1.8	5.25	10-lead MSOP	EAR99
LT1001	1	25	0.2	2	0.8	0.25	9.6	0.3	1.5	6	44	8-lead PDIP, 8-lead SOIC	EAR99
LT1007	1	25	0.2	35	8	2.5	2.5	0.06	2.6	4	44	8-lead PDIP, 8-lead SOIC	EAR99
LT1012	1	25	0.2	0.1	1	0.2	14	0.5	0.37	2.4	40	8-lead PDIP, 8-lead SOIC	EAR99
LT1037	1	25	0.2	35	60	15	2.5	0.06	2.6	8	44	8-lead PDIP, 8-lead SOIC	EAR99
LTC6078	2	25	0.2	0.001	0.75	0.05	18	1	0.054	2.7	5.5	8-lead MSOP, 10-lead DFN	EAR99
LTC6079	4	25	0.3	0.001	0.75	0.05	18	1	0.054	2.7	5.5	16-lead SSOP, 16-lead DFN	EAR99
AD708	2	30	0.1	1	0.9	0.3	9.6	0.23	2.75	6	36	8-lead PDIP, 8-lead CerDIP	EAR99
LT6020	2	30	0.2	1	0.4	5	50	1.1	0.09	3	30	8-lead MSOP, 8-lead DFN, 10-lead DFN	EAR99
LT6020-1	2	30	0.2	1	0.4	5	50	1.1	0.09	3	30	8-lead MSOP, 8-lead DFN, 10-lead DFN	EAR99
LT6023	2	30	0.5	3	0.04	1.45	132		0.018	3	30	8-lead MSOP, 8-lead DFN, 10-lead DFN	EAR99
LT6023-1	2	30	0.5	3	0.04	1.45	132		0.018	3	30	8-lead MSOP, 8-lead DFN, 10-lead DFN	EAR99
LT6010	1	35	0.2	0.11	0.33	0.09	14	0.4	0.135	2.7	40	8-lead SOIC, 8-lead DFN	EAR99
LT6013	1	35	0.2	0.25	1.6	0.2	9.5	0.2	0.145	2.7	40	8-lead SOIC, 8-lead DFN	EAR99
ADA4077-1	1	35	0.25	1	3.9	1	7	0.25	0.4	5	30	8-lead SOIC, 8-lead MSOP	EAR99
ADA4077-2	2	35	0.25	1	3.9	1	7	0.25	0.4	5	30	8-lead SOIC, 8-lead MSOP	EAR99
ADA4530-1	1	40	0.13	0.00002	2	1.4	14	4	0.9	4.5	16	8-lead SOIC	EAR99
AD797	1	40	0.2	900	110	20	0.9	0.05	10.5	10	36	8-lead PDIP, 8-lead SOIC	EAR99
LT1028	1	40	0.2	90	75	15	0.85	0.035	7.4	8	44	8-lead PDIP, 8-lead SOIC, 16-lead SOIC	EAR99
LT1128	1	40	0.2	90	20	6	0.85	0.035	7.4	8	44	8-lead PDIP, 8-lead SOIC	EAR99
LT1077	1	40	0.4	9	0.23	0.08	27	0.5	0.048	2.2	44	8-lead PDIP, 8-lead SOIC	EAR99
AD8676	2	50	0.2	2	10	2.5	2.8	0.1	2.9	10	30	8-lead SOIC, 8-lead MSOP	EAR99
LT1006	1	50	0.2	15	0.6	0.4	22	0.55	0.34	4	44	8-lead PDIP, 8-lead SOIC	EAR99
LT6018	1	50	0.2	150	15	30	1.2	0.03	7.2	8	33	8-lead SOIC-EP, 12-lead DFN	EAR99
ADA4077-4	4	50	0.25	1	3.9	1	7	0.25	0.4	5	30	14-lead SOIC, 14-lead TSSOP	EAR99
LT1024	2	50	0.25	0.12	1	0.2	14	0.5	0.38	4	40	14-lead PDIP	EAR99
LT1097	1	50	0.3	0.25	0.7	0.2	14	0.5	0.35	2	40	8-lead PDIP, 8-lead SOIC	EAR99
LT1881	2	50	0.3	0.2	1	0.35	14	0.5	0.65	2.4	40	8-lead PDIP, 8-lead SOIC	EAR99
LT1884	2	50	0.3	0.4	2	0.9	9.5	0.4	0.65	2.4	40	8-lead PDIP, 8-lead SOIC	EAR99
LT1991	1	50	0.3	5	0.56	0.12	46	0.35	0.1	2.4	40	10-lead MSOP, 10-lead DFN	EAR99
LT1996	1	50	0.3	5	0.56	0.12	18	0.35	0.1	2.7	36	10-lead MSOP, 10-lead DFN	EAR99
LT6015	1	50	0.75	5	3.2	0.75	18	0.5	0.315	3	50	5-lead SOT-23	EAR99
LT6016	2	50	0.75	5	3.2	0.75	18	0.5	0.315	3	50	8-lead MSOP	EAR99
LT6017	4	50	0.75	5	3.2	0.75	18	0.5	0.315	3	50	22-lead DFN	EAR99
LT1112	2	60	0.15	0.25	0.75	0.3	14	0.3	0.35	2	40	8-lead PDIP, 8-lead SOIC	EAR99
LT1002	2	60	0.2	3	0.8	0.25	9.6	0.35	1.53	6	44	14-lead PDIP	EAR99
LT1677	1	60	0.2	20	7.2	2.5	3.2	0.09	2.75	2.5	44	8-lead PDIP, 8-lead SOIC	EAR99
LT6011	2	60	0.2	0.3	0.33	0.09	14	0.4	0.135	2.4	40	8-lead SOIC, 8-lead MSOP, 8-lead DFN	EAR99
LT6012	4	60	0.2	0.3	0.33	0.09	14	0.4	0.135	2.4	40	14-lead SOIC, 16-lead SSOP	EAR99
LT6014	2	60	0.2	0.4	1.6	0.2	9.5	0.2	0.145	2.7	40	8-lead SOIC, 8-lead DFN	EAR99
LT1114	4	60	0.3	0.25	0.75	0.3	14	0.3	0.35	2	40	14-lead PDIP, 16-lead SOIC	EAR99
LT1997-3	1	60	0.5	5	1.1	0.75	50	1.4	0.35	3.3	50	16-lead MSOP (4 pins removed), 14-lead DFN	EAR99

Operational Amplifiers (Op Amps)

Precision ($V_{os} < 1\text{ mV}$ and $TCV_{os} < 2\ \mu\text{V}/^\circ\text{C}$) Amplifiers (Continued)

Part Number	Number of Amps	V_{os} (max) (μV)	V_{os} TC (typ) ($\mu\text{V}/^\circ\text{C}$)	I_{BIAS} (max) (nA)	GBP (typ) (MHz)	Slew Rate (typ) (V/ μs)	V_{NOISE} Density (typ) (nV/ $\sqrt{\text{Hz}}$)	0.1 Hz to 10 Hz V_{NOISE} (typ) (μV p-p)	I_o /Amp (typ) (mA)	V_s Span (min) (V)	V_s Span (max) (V)	Package	ECCN code
ADA4177-1	1	60	1	1	3.5	1.5	8	0.175	0.5	10	30	8-lead SOIC, 8-lead MSOP	EAR99
ADA4177-2	2	60	1	1	3.5	1.5	8	0.175	0.5	10	30	8-lead SOIC, 8-lead MSOP	EAR99
ADA4177-4	4	60	1	1	3.5	1.5	8	0.175	0.5	10	30	14-lead SOIC, 14-lead TSSOP	EAR99
AD8616	2	60	1.5	0.001	24	12	7	2.4	1.7	2.7	5.5	8-lead SOIC, 8-lead MSOP	EAR99
AD8618	4	60	1.5	0.001	24	12	7	2.4	2	2.7	5.5	14-lead SOIC, 14-lead TSSOP	EAR99
LTC6081	2	70	0.2	0.001	3.6	1	13	1.3	0.33	2.7	5.5	8-lead MSOP, 10-lead DFN	EAR99
LTC6082	4	70	0.2	0.001	3.6	1	13	1.3	0.33	2.7	5.5	16-lead SSOP, 16-lead DFN	EAR99
LT1124	2	70	0.3	20	12.5	4.5	2.7	0.07	2.3	8	44	8-lead PDIP, 8-lead SOIC	EAR99
LT1126	2	70	0.3	20	65	11	2.7	0.07	2.6	8	44	8-lead PDIP, 8-lead SOIC	EAR99
LT1078	2	70	0.4	8	0.2	0.07	28	0.6	0.038	2.2	44	8-lead PDIP, 8-lead SOIC, 16-lead SOIC	EAR99
LT2078	2	70	0.4	8	0.2	0.07	28	0.6	0.035	2.3	44	8-lead SOIC	EAR99
LT2178	2	70	0.4	5	0.06	0.025	49	0.9	0.013	2.2	44	8-lead SOIC	EAR99
LT1178	2	70	0.6	5	0.085	0.04	49	0.9	0.012	2	44	8-lead PDIP, 8-lead SOIC, 16-lead SOIC	EAR99
AD8671	1	75	0.5	12	10	4	2.8	0.077	3.5	8	36	8-lead SOIC, 8-lead MSOP	EAR99
AD8672	2	75	0.5	12	10	4	2.8	0.077	3.5	8	36	8-lead SOIC, 8-lead MSOP	EAR99
AD8675	1	75	0.6	2	10	2.5	2.8	0.1	2.9	10	30	8-lead SOIC, 8-lead MSOP	EAR99
AD8674	4	75	0.8	12	10	4	2.8	0.077	3.5	8	36	14-lead SOIC, 14-lead TSSOP	EAR99
ADA4350	1	80	0.1	0.001	175	100	5		8.5	3.3	12	28-lead TSSOP	EAR99
LT1882	4	80	0.3	0.5	1	0.35	14	0.5	0.65	2.4	40	14-lead SOIC	EAR99
LT1885	4	80	0.3	0.9	2	0.9	9.5	0.4	0.65	2.4	40	14-lead SOIC	EAR99
LT1125	4	90	0.3	20	12.5	4.5	2.7	0.07	2.3	8	44	14-lead PDIP, 16-lead SOIC	EAR99
LT1127	4	90	0.3	20	65	11	2.7	0.07	2.6	8	44	14-lead PDIP, 16-lead SOIC	EAR99
LT1218	1	90	1	70	0.3	0.1	33		0.37	2	36	8-lead PDIP, 8-lead SOIC	EAR99
LT1218L	1	90	1	70	0.3	0.1	33		0.37	2	16	8-lead PDIP, 8-lead SOIC	EAR99
LT1219	1	90	1	70	0.15	0.05	33		0.37	2	36	8-lead PDIP, 8-lead SOIC	EAR99
LT1219L	1	90	1	70	0.15	0.05	33		0.37	2	16	8-lead PDIP, 8-lead SOIC	EAR99
AD706	2	100	0.2	0.2	0.8	0.15	15	0.5	0.6	4	36	8-lead PDIP, 8-lead SOIC	EAR99
LT1079	4	100	0.4	8	0.2	0.07	28	0.6	0.038	2.2	44	14-lead PDIP, 16-lead SOIC	EAR99
LT1079MJ	4	100	0.4	8	0.2	0.07	28	0.6	0.038	2.2	44	14-lead PDIP, 16-lead SOIC	EAR99
LT1678	2	100	0.4	20	20	6	3.9	0.09	2	3	36	8-lead SOIC	EAR99
LT1679	4	100	0.4	20	20	6	3.9		2	3	36	14-lead SOIC	EAR99
AD8610	1	100	0.5	0.01	25	60	6	1.8	3.5	10	26	8-lead SOIC, 8-lead MSOP	EAR99
ADA4084-1	1	100	0.5	250	15.9	4.6	3.9	0.1	0.625	3	30	8-lead SOIC, 5-lead SOT-23	EAR99
ADA4084-2	2	100	0.5	250	15.9	4.6	3.9	0.1	0.625	3	30	8-lead LFCSP, 8-lead SOIC, 8-lead MSOP	EAR99
ADA4084-4	4	100	0.5	250	15.9	4.6	3.9	0.1	0.625	3	30	16-lead LFCSP, 14-lead TSSOP	EAR99
LT2179	4	100	0.5	5	0.06	0.025	49	0.9	0.013	2.2	44	14-lead SOIC, 8-lead SOIC	EAR99
LT1179	4	100	0.6	5	0.085	0.04	49	0.9	0.012	2	44	14-lead PDIP, 16-lead SOIC	EAR99
LTC6244	2	100	0.7	0.075	50	35	8	1.5	6.25	2.8	6	8-lead MSOP, 8-lead DFN	EAR99
LTC6244HV	2	100	0.7	0.075	50	35	8	1.5	6.25	2.8	12	8-lead MSOP, 8-lead DFN	EAR99
LT2079	4	110	0.6	8	0.2	0.07	28	0.6	0.035	2.3	44	14-lead SOIC	EAR99
LT1008	1	120	0.2	0.1	1	0.2	14	0.5	0.38	4	40	8-lead PDIP, 8-lead SOIC	EAR99
AD8597	1	120	0.8	200	10	16	1.07	0.076	5.7	9	30	8-lead LFCSP, 8-lead SOIC	EAR99
AD8599	2	120	0.8	200	10	16	1.07	0.076	5.7	9	36	8-lead SOIC	EAR99
ADA4500-2	2	120	0.9	0.002	10	5.5	14.5	2	1.55	2.7	5.5	8-lead LFCSP, 8-lead MSOP	EAR99

Operational Amplifiers (Op Amps)

Precision ($V_{os} < 1\text{ mV}$ and $TCV_{os} < 2\ \mu\text{V}/^\circ\text{C}$) Amplifiers (Continued)

Part Number	Number of Amps	V_{os} (max) (μV)	V_{os} TC (typ) ($\mu\text{V}/^\circ\text{C}$)	I_{BIAS} (max) (nA)	GBP (typ) (MHz)	Slew Rate (typ) ($\text{V}/\mu\text{s}$)	V_{NOISE} Density (typ) ($\text{nV}/\sqrt{\text{Hz}}$)	0.1 Hz to 10 Hz V_{NOISE} (typ) ($\mu\text{V p-p}$)	I_o /Amp (typ) (mA)	V_s Span (min) (V)	V_s Span (max) (V)	Package	ECCN code
ADA4806-1	1	125	0.2	800	30	160	5.2		0.57	3	10	8-lead SOT-23	EAR99
AD8622	2	125	0.5	0.2	0.56	0.48	11	0.2	0.215	5	36	8-lead SOIC, 8-lead MSOP	EAR99
AD8624	4	125	0.5	0.2	0.56	0.48	11	0.2	0.215	5	36	16-lead LFCSP, 14-lead TSSOP	EAR99
ADA4004-1	1	125	0.7	90	12	2.7	1.8	0.15	2.2	10	30	8-lead SOIC, 5-lead SOT-23	EAR99
ADA4004-2	2	125	0.7	90	12	2.7	1.8	0.15	2.2	10	30	8-lead SOIC, 8-lead MSOP	EAR99
ADA4004-4	4	125	0.7	90	12	2.7	1.8	0.15	2.2	10	30	16-lead LFCSP, 14-lead SOIC	EAR99
ADA4807-1	1	125	0.7	1600	200	225	3.3	0.16	1	2.7	11	6-lead SC70, 6-lead SOT-23	EAR99
ADA4807-2	2	125	0.7	1600	200	225	3.3	0.16	1	2.7	11	10-lead LFCSP, 8-lead MSOP	EAR99
LTC6241	2	125	0.7	0.075	18	10	7	1	1.8	2.8	6	8-lead SOIC, 8-lead DFN	EAR99
LTC6241HV	2	125	0.7	0.075	18	10	7	1	1.8	2.8	12	8-lead SOIC, 8-lead DFN	EAR99
LTC6242	4	125	0.7	0.075	18	10	7	1	1.8	2.8	6	16-lead SSOP, 16-lead DFN	EAR99
LTC6242HV	4	125	0.7	0.075	18	10	7	1	1.8	2.8	12	16-lead SSOP, 16-lead DFN	EAR99
ADA4898-1	1	125	1	400	50	55	0.9		8.1	9	36	8-lead SOIC-EP	EAR99
ADA4898-2	2	125	1	400	50	55	0.9		7.9	9	36	8-lead SOIC-EP	EAR99
AD8677	1	130	0.5	1	0.6	0.2	10	0.25	1.3	8	36	8-lead SOIC, 5-lead TSOT	EAR99
LT1493	4	130	1	100	4.5	1.8	16.5	0.33	0.425	2.1	36	16-lead SOIC	EAR99
AD704	4	150	0.2	0.27	0.8	0.15	15	0.5	0.6	4	36	20-lead LCC, 14-lead PDIP, 16-lead SOIC—wide	EAR99
LT1013	2	150	0.3	20	0.8	0.4	22	0.55	0.35	4	44	8-lead PDIP, 8-lead SOIC	EAR99
LT1013AMH	2	150	0.3	20	0.8	0.4	22	0.55	0.35	4	44	8-lead PDIP, 8-lead SOIC	EAR99
LT1014	4	150	0.3	20	0.8	0.4	22	0.55	0.35	4	44	14-lead PDIP, 16-lead SOIC	EAR99
LT1880	1	150	0.3	0.9	1.1	0.55	13	0.5	1.2	2.4	40	5-lead SOT-23	EAR99
AD8620	2	150	0.5	0.01	25	60	6	1.8	3.5	10	26	8-lead SOIC	EAR99
ADA4661-2	2	150	0.6	0.015	4	2.2	18	3	0.63	3	18	8-lead LFCSP, 8-lead MSOP	EAR99
LT1211	2	150	0.7	100	13	7	12	0.25	1.3	2.5	36	8-lead PDIP, 8-lead SOIC	EAR99
LT1211MJ8	2	150	0.7	100	13	7	12	0.25	1.3	2.5	36	8-lead PDIP, 8-lead SOIC	EAR99
LT1213	2	150	0.75	160	28	8.5	10	0.2	2.7	2.5	36	8-lead PDIP, 8-lead SOIC	EAR99
LT1213MJ8	2	150	0.75	160	28	8.5	10	0.2	2.7	2.5	36	8-lead PDIP, 8-lead SOIC	EAR99
AD844	1	150	1	250		2000	2		6.5	9	36	8-lead PDIP, 8-lead CerDIP, 16-lead SOIC—wide, chips or die	EAR99
AD8664	4	160	2	0.001	4	3.5	10	2.5	1.55	5	16	14-lead SOIC, 14-lead TSSOP	EAR99
LT1007X		160		95	8	1.2			2.8	10	30		EAR99
ADA4807-4	4	175	0.7	1600	200	225	3.3	0.16	1	2.7	11	14-lead TSSOP	EAR99
LTC6240	1	175	0.7	0.001	18	10	7	0.55	2	2.8	6	8-lead SOIC, 5-lead SOT-23	EAR99
LTC6240HV	1	175	0.7	0.001	18	10	7	0.55	2	2.8	12	8-lead SOIC, 5-lead SOT-23	EAR99
LT1492	2	180	1	100	4.5	1.8	16.5	0.33	0.425	2.1	36	8-lead PDIP, 8-lead SOIC	EAR99
LT1115	1	200	0.5	380	70	15	0.9		8.5	8	44	8-lead PDIP, 16-lead SOIC	EAR99
ADA4627-1	1	200	1	0.005	19	56	4.8	0.7	7	9	36	8-lead LFCSP, 8-lead SOIC	EAR99
ADA4637-1	1	200	1	0.005	79.9	170	4.8	0.7	7	9	30	8-lead LFCSP, 8-lead SOIC	EAR99
LT1636	1	225	1	8	0.2	0.07	52	0.7	0.042	2.6	44	8-lead PDIP, 8-lead SOIC, 8-lead MSOP, 8-lead DFN	EAR99
AD8634	2	250	0.35	200	9.7	5	4.2	0.13	1.1	3	30	Chips or die, 8-lead flatpack, 8-lead SOIC	EAR99
AD8655	1	250	0.4	0.01	28	11	2.7		4.5	2.7	5.5	8-lead SOIC, 8-lead MSOP	EAR99
AD8656	2	250	0.4	0.01	28	11	2.7		4.5	2.7	5.5	8-lead SOIC, 8-lead MSOP	EAR99
LT1022	1	250	1.3	0.05	8.5	26	14	2.5	5.2	20	40	8-lead PDIP	EAR99

Operational Amplifiers (Op Amps)

Precision ($V_{os} < 1 \text{ mV}$ and $TCV_{os} < 2 \mu\text{V}/^\circ\text{C}$) Amplifiers (Continued)

Part Number	Number of Amps	V_{os} (max) (μV)	V_{os} TC (typ) ($\mu\text{V}/^\circ\text{C}$)	I_{BIAS} (max) (nA)	GBP (typ) (MHz)	Slew Rate (typ) (V/ μs)	V_{NOISE} Density (typ) (nV/ $\sqrt{\text{Hz}}$)	0.1 Hz to 10 Hz V_{NOISE} (typ) (μV p-p)	I_o /Amp (typ) (mA)	V_s Span (min) (V)	V_s Span (max) (V)	Package	ECCN code
LT1212	4	275	1	125	13	7	12	0.25	1.3	2.5	36	14-lead PDIP, 16-lead SOIC	EAR99
LT1214	4	275	1	200	28	8.5	10	0.2	2.7	2.5	36	14-lead PDIP, 16-lead SOIC	EAR99
AD8603	1	300	1	0.001	0.316	0.1	22	2.3	0.05	1.8	5	5-lead TSOT	EAR99
AD8605	1	300	1	0.001	10	5	6.5	2.3	1.2	2.7	5	5-ball WLCSOP, 5-lead SOT-23	EAR99
AD8606	2	300	1	0.001	10	5	6.5	2.3	1.2	2.7	5	8-ball WLCSOP, 8-lead SOIC, 8-lead MSOP	EAR99
AD8607	2	300	1	0.001	0.316	0.1	22	2.3	0.05	1.8	5	8-lead SOIC, 8-lead MSOP	EAR99
AD8609	4	300	1	0.001	0.316	0.1	22	2.3	0.04	1.8	5	14-lead SOIC, 14-lead TSSOP	EAR99
ADA4096-2	2	300	1	25	0.786	0.4	27	0.7	0.06	3	30	8-lead LFCSP, 8-lead MSOP	EAR99
ADA4096-4	4	300	1	25	0.786	0.4	27	0.7	0.06	3	30	16-lead LFCSP, 14-lead TSSOP	EAR99
ADA4841-1	1	300	1	5300	35	13	2.1		1.2	2.7	12	8-lead SOIC, 6-lead SOT-23	EAR99
ADA4841-2	2	300	1	5300	35	13	2.1		1.2	2.7	12	8-lead LFCSP, 8-lead SOIC, 8-lead MSOP, chips or die	EAR99
LT1215	2	300	1	500	23	30	12	0.4	4.75	2.5	36	8-lead PDIP, 8-lead SOIC	EAR99
AD8608	4	300	1.5	0.001	10	5	6.5	2.3	1.2	2.7	5	Chips or die, 14-lead SOIC, 14-lead TSSOP	EAR99
AD8663	1	300	1.5	0.045	0.54	0.3	21	2.5	0.285	5	16	8-lead LFCSP, 8-lead SOIC	EAR99
AD8667	2	300	1.5	0.045	0.54	0.3	21	2.5	0.285	5	16	8-lead SOIC, 8-lead MSOP	EAR99
AD8669	4	300	1.5	0.045	0.54	0.3	21	2.5	0.285	5	16	14-lead SOIC, 14-lead TSSOP	EAR99
ADA4895-1	1	350	0.15	6000	1500	943	1	0.099	3	3	10	8-lead SOIC, 6-lead SOT-23	EAR99
ADA4895-2	2	350	0.15	6000	1500	943	1	0.099	3	3	10	10-lead MSOP	EAR99
LT6231	2	350	0.5	10,000	215	70	1.1	0.18	3.3	3	12.6	8-lead SOIC, 8-lead DFN	EAR99
LT6232	4	350	0.5	10,000	215	70	1.1	0.18	3.3	3	12.6	16-lead SSOP	EAR99
LT6234	2	350	0.5	3000	60	17	1.9	0.22	1.15	3	12.6	8-lead SOIC, 8-lead DFN	EAR99
LT6235	4	350	0.5	3000	60	17	1.9	0.22	1.15	3	12.6	16-lead SSOP	EAR99
LT1637	1	350	1	50	1	0.35	27	0.6	0.19	2.7	44	8-lead PDIP, 8-lead SOIC, 8-lead MSOP, 8-lead DFN	EAR99
LT1800	1	350	1.5	250	80	25	8.5	1.4	1.6	2.3	12.6	8-lead SOIC, 5-lead SOT-23	EAR99
LT1801	2	350	1.5	250	80	25	8.5	1.4	1.6	2.3	12.6	8-lead SOIC, 8-lead MSOP, 8-lead DFN	EAR99
LT1802	4	350	1.5	250	80	25	8.5	1.4	1.6	2.3	12.6	14-lead SOIC	EAR99
LT6220	1	350	1.5	150	60	20	10	0.5	0.9	2.2	12.6	8-lead SOIC, 5-lead SOT-23	EAR99
LT6221	2	350	1.5	150	60	20	10	0.5	0.9	2.2	12.6	8-lead SOIC, 8-lead DFN	EAR99
LT6222	4	350	1.5	150	60	20	10	0.5	0.9	2.2	12.6	16-lead SSOP	EAR99
LTC6255	1	350	1.5	50	6.5	1.8	21	2.5	0.06	1.8	5.25	6-lead SOT-23, 6-lead DFN	EAR99
LTC6256	2	350	1.5	50	6.5	1.8	21	2.5	0.065	1.8	5.25	8-lead SOT-23, 8-lead MSOP, 10-lead MSOP, 8-lead DFN	EAR99
LTC6257	4	350	1.5	50	6.5	1.8	21	2.5	0.065	1.8	5.25	16-lead MSOP	EAR99
AD8657	2	350	2	0.02	0.23	0.08	45	5	0.022	2.7	18	8-lead LFCSP, 8-lead MSOP	EAR99
AD8659	4	350	2	0.02	0.23	0.08	45	5	0.022	2.7	18	16-lead LFCSP, 14-lead SOIC	EAR99
ADA4622-1	1	350	2	0.01	8	23	12.5	0.75	0.715	5	30	8-lead SOIC, 5-lead SOT-23	EAR99
ADA4622-2	2	350	2	0.01	8	23	12.5	0.75	0.665	5	30	8-lead LFCSP, 8-lead SOIC, 8-lead MSOP	EAR99
ADA4622-4	4	350	2	0.01	8	23	12.5	0.75	0.665	5	30	16-lead LFCSP, 14-lead SOIC	EAR99

Operational Amplifiers (Op Amps)

Precision ($V_{os} < 1\text{ mV}$ and $TCV_{os} < 2\ \mu\text{V}/^\circ\text{C}$) Amplifiers (Continued)

Part Number	Number of Amps	V_{os} (max) (μV)	V_{os} TC (typ) ($\mu\text{V}/^\circ\text{C}$)	I_{BIAS} (max) (nA)	GBP (typ) (MHz)	Slew Rate (typ) ($\text{V}/\mu\text{s}$)	V_{NOISE} Density (typ) ($\text{nV}/\sqrt{\text{Hz}}$)	0.1 Hz to 10 Hz V_{NOISE} (typ) ($\mu\text{V p-p}$)	I_o /Amp (typ) (mA)	V_s Span (min) (V)	V_s Span (max) (V)	Package	ECCN code
LT1494	1	375	0.4	1	0.003	0.001	185	4	0.001	2.1	36	8-lead PDIP, 8-lead SOIC, 8-lead MSOP	EAR99
LT1495	2	375	0.4	1	0.003	0.001	185	4	0.001	2.1	36	8-lead PDIP, 8-lead SOIC	EAR99
LT1496	4	375	0.4	1	0.003	0.001	185	4	0.001	2.1	36	14-lead PDIP, 14-lead SOIC	EAR99
LT1672	1	375	0.4	1	0.012	0.005	185	4	0.002	2.1	36	8-lead PDIP, 8-lead SOIC, 8-lead MSOP	EAR99
LT1673	2	375	0.4	1	0.012	0.005	185	4	0.002	2.1	36	8-lead PDIP, 8-lead SOIC	EAR99
LT1674	4	375	0.4	1	0.012	0.005	185	4	0.002	2.1	36	14-lead PDIP, 14-lead SOIC	EAR99
LT1466L	2	390	2	14	0.12	0.04	45		0.06	2	16	8-lead PDIP, 8-lead SOIC	EAR99
LT1467L	4	390	2	14	0.12	0.04	45		0.06	2	16	16-lead SOIC	EAR99
LTC6261	1	400	0.4	100	30	7	13	1.25	0.245	1.8	5.25	6-lead SOT-23, 6-lead DFN	EAR99
LTC6262	2	400	0.4	100	30	7	13	1.25	0.245	1.8	5.25	8-lead SOT-23, 8-lead MSOP, 10-lead MSOP, 6-lead DFN, 8-lead DFN	EAR99
LTC6263	4	400	0.4	750	30	7	13	1.25	0.245	1.8	5.25	16-lead MSOP	EAR99
ADA4610-2	2	400	0.5	0.025	16.3	25	7.3	0.45	1.6	10	36	8-lead LFCSP, 8-lead SOIC, 8-lead MSOP	EAR99
AD8510	1	400	1	0.08	8	20	7.6		2.5	9	30	8-lead SOIC, 8-lead MSOP	EAR99
AD8512	2	400	1	0.08	8	20	7.6		2.5	9	30	8-lead SOIC, 8-lead MSOP	EAR99
ADA4610-4	4	400	1	0.025	16.3	25	7.3	0.45	1.6	10	36	16-lead LFCSP, 14-lead SOIC	EAR99
LTC6258	1	400	1.5	75	1.3	0.24	38	2	0.02	1.8	5.25	6-lead SOT-23, 6-lead DFN	EAR99
LTC6259	2	400	1.5	75	1.3	0.24	38	2	0.02	1.8	5.25	8-lead SOT-23, 8-lead MSOP, 10-lead MSOP, 8-lead DFN	EAR99
LT1216	4	450	2	600	23	30	12	0.4	4.75	2.5	36	14-lead PDIP, 16-lead SOIC	EAR99
LT1498	2	475	0.5	650	10.5	4.5	12	0.4	1.7	2.2	36	8-lead PDIP, 8-lead SOIC	EAR99
LT1499	4	475	0.5	650	10.5	4.5	12	0.4	1.7	2.2	36	14-lead SOIC	EAR99
LT1366	2	475	2	35	0.4	0.13	29		0.34	2	36	8-lead PDIP, 8-lead SOIC	EAR99
LT1368	2	475	2	35	0.16	0.065	29		0.34	2	36	8-lead PDIP, 8-lead SOIC	EAR99
ADA4896-2	2	500	0.2	17,000	90	120	1	0.099	3	3	10	8-lead LFCSP, 8-lead MSOP	EAR99
ADA4897-1	1	500	0.2	17,000	90	120	1	0.099	3	3	10	8-lead SOIC, 6-lead SOT-23	EAR99
ADA4897-2	2	500	0.2	17,000	90	120	1	0.099	3	3	10	Chips or die, 10-lead MSOP	EAR99
LT6230	1	500	0.5	10,000	215	70	1.1	0.18	3.3	3	12.6	6-lead SOT-23	EAR99
LT6230-10	1	500	0.5	10,000	1450	250	1.1	0.18	3.3	3	12.6	6-lead SOT-23	EAR99
LT6233	1	500	0.5	3000	60	15	1.9	0.22	1.15	3	12.6	6-lead SOT-23	EAR99
LT6233-10	1	500	0.5	3000	375	80	1.9	0.22	1.15	3	12.6	6-lead SOT-23	EAR99
LT6236	1	500	0.5	10,000	215	60	1.1	0.18	3.15	3	12.6	6-lead SOT-23	EAR99
LT6237	2	500	0.5	10,000	215	60	1.1	0.18	3.15	3	12.6	8-lead MSOP, 8-lead DFN	EAR99
LT6238	4	500	0.5	10,000	215	60	1.1	0.18	3.15	3	12.6	16-lead SSOP	EAR99
AD8601	1	500	2	0.06	8.4	6	18		0.75	2.7	5	5-lead SOT-23	EAR99
AD8602	2	500	2	0.06	8.4	6	18		0.75	2.7	5.5	8-lead SOIC, 8-lead MSOP	EAR99
LT1490A	2	500	2	8	0.18	0.06	50	1	0.04	2	44	8-lead PDIP, 8-lead SOIC, 8-lead MSOP, 8-lead DFN	EAR99
LT6003	1	500	2	0.09	0.002	0.001	325	3	0.001	1.6	16	5-lead SOT-23, 4-lead DFN	EAR99
LT6004	2	500	2	0.09	0.002	0.001	325	3	0.001	1.6	16	8-lead MSOP, 8-lead DFN	EAR99
LTC6246	1	500	2	350	180	90	4.2		0.95	2.5	5.25	6-lead SOT-23	EAR99
LTC6247	2	500	2	350	180	90	4.2		0.95	2.5	5.25	8-lead SOT-23, 8-lead MSOP, 10-lead MSOP, 8-lead DFN	EAR99

Operational Amplifiers (Op Amps)

Precision ($V_{os} < 1 \text{ mV}$ and $TCV_{os} < 2 \mu\text{V}/^\circ\text{C}$) Amplifiers (Continued)

Part Number	Number of Amps	V_{os} (max) (μV)	V_{os} TC (typ) ($\mu\text{V}/^\circ\text{C}$)	I_{BIAS} (max) (nA)	GBP (typ) (MHz)	Slew Rate (typ) (V/ μs)	V_{NOISE} Density (typ) (nV/ $\sqrt{\text{Hz}}$)	0.1 Hz to 10 Hz V_{NOISE} (typ) ($\mu\text{V p-p}$)	I_o /Amp (typ) (mA)	V_s Span (min) (V)	V_s Span (max) (V)	Package	ECCN code
LTC6248	4	500	2	350	180	90	4.2		0.95	2.5	5.25	16-lead MSOP	EAR99
LT1806	1	550	1.5	4000	325	125	3.5	0.8	9	2.5	12.6	8-lead SOIC, 6-lead SOT-23	EAR99
LT1807	2	550	1.5	4000	325	125	3.5	0.8	9	2.5	12.6	8-lead SOIC, 8-lead MSOP	EAR99
AD8604	4	600	2	0.06	8.4	6	18		0.75	2.7	5.5	14-lead SOIC, 16-lead QSOP, 14-lead TSSOP	EAR99
LT1638	2	600	2	50	1.2	0.38	20	1	0.17	2.5	44	8-lead PDIP, 8-lead SOIC, 8-lead MSOP, 8-lead DFN	EAR99
LT1639	4	600	2	50	1.075	0.38	20	1	0.17	2.5	44	14-lead PDIP, 14-lead SOIC	EAR99
LT6001	2	600	2	5	0.05	0.015	75		0.013	1.8	18	8-lead MSOP, 10-lead DFN	EAR99
LT6005	4	650	2	0.09	0.002	0.001	325	3	0.001	1.6	16	16-lead SSOP, 16-lead DFN	EAR99
LT6000	1	750	2	5	0.05	0.015	75		0.013	1.8	18	6-lead DFN	EAR99
LT6002	4	750	2	5	0.05	0.015	75		0.013	1.8	18	16-lead SSOP, 16-lead DFN	EAR99
LTC6084	2	750	2	0.04	1.5	0.5	31	3	0.11	2.5	5.5	8-lead MSOP, 10-lead DFN	EAR99
LTC6085	4	750	2	0.04	1.5	0.5	31	3	0.11	2.5	5.5	16-lead SSOP, 16-lead DFN	EAR99
LTC6087	2	750	2	0.04	14	7.2	12	5.8	1.05	2.7	5.5	8-lead MSOP, 10-lead DFN	EAR99
LTC6088	4	750	2	0.04	14	7.2	12	5.8	1.05	2.7	5.5	16-lead SSOP, 16-lead DFN	EAR99
LT1367	4	800	2	35	0.4	0.13	29		0.34	2	36	14-lead SOIC	EAR99
LT1369	4	800	2	35	0.16	0.065	29		0.34	2	36	14-lead SOIC	EAR99
LT1782	1	800	2	15	0.2	0.07	50	1	0.04	2.2	18	5-lead SOT-23, 6-lead SOT-23	EAR99
LT1783	1	800	2	80	1.25	0.42	20	0.6	0.21	2.2	18	5-lead SOT-23, 6-lead SOT-23	EAR99
AD8027	1	900	1.5	6,000	190	100	4.3		6.5	2.7	12	8-lead SOIC, 6-lead SOT-23	EAR99
AD8028	2	900	1.5	6000	190	100	4.3		6.5	2.7	12	Chips or die, 8-lead SOIC, 10-lead MSOP	EAR99
AD829	1	1000	0.3	7000	750	230	1.7		5.3	9	36	20-lead LCC, 8-lead PDIP, 8-lead CerDIP, 8-lead SOIC, chips or die	EAR99
ADA4075-2	2	1000	0.3	100	6.5	12	2.8	0.06	2.25	9	36	8-lead LFCSP, 8-lead SOIC	EAR99
AD8021	1	1000	0.5	11,300	1000	130	2.1		7.8	4.5	24	8-lead SOIC, 8-lead MSOP	EAR99
AD8067	1	1000	1	0.005	200	640	6.6		7	5	24	5-lead SOT-23	EAR99
AD8513	4	1000	1.7	0.08	8	20	7.6		2.5	9	30	14-lead SOIC, 14-lead TSSOP	EAR99
AD820	1	1000	2	0.01	1.8	3	13	2	0.9	5	30	8-lead PDIP, 8-lead SOIC, 8-lead MSOP	EAR99
LT1491A	4	1000	2	8	0.18	0.06	50	1	0.04	2	44	14-lead PDIP, 14-lead SOIC, 16-lead DFN	EAR99

Operational Amplifiers (Op Amps)

LTC2063/LTC2064: 2 μ A Supply Current, Low I_{BIAS} , Zero-Drift Op Amp

Key Features

- ▶ Low supply current: 2 μ A maximum
- ▶ Offset voltage: 5 μ V maximum
- ▶ Offset voltage drift: 0.02 μ V/ $^{\circ}$ C maximum
- ▶ Input bias current
 - 3 pA typical
 - 30 pA maximum, -40° C to $+85^{\circ}$ C
 - 100 pA maximum, -40° C to $+125^{\circ}$ C
- ▶ Integrated EMI filter (114 dB rejection at 1.8 GHz)
- ▶ Shutdown current: 170 nA maximum

Benefits

- ▶ Enables high accuracy in micropower applications by combining zero drift with extremely low supply current
- ▶ 1.7 V to 5.25 V supply range allows for use with small battery stack
- ▶ Low input bias current allows for large resistors, as typical in micropower applications
- ▶ RRIO, small package, and integrated EMI filter provide a robust set of characteristics for general use
- ▶ The LTC2063 makes it easy for portable systems by featuring low shutdown quiescent current and minimal charge draw from a supply during power-up

Applications

- ▶ Signal conditioning in wireless mesh networks
- ▶ Portable instrumentation systems
- ▶ Low power sensor conditioning
- ▶ Gas detection
- ▶ Temperature measurement
- ▶ Medical instrumentation
- ▶ Energy harvesting applications
- ▶ Low power current sensing

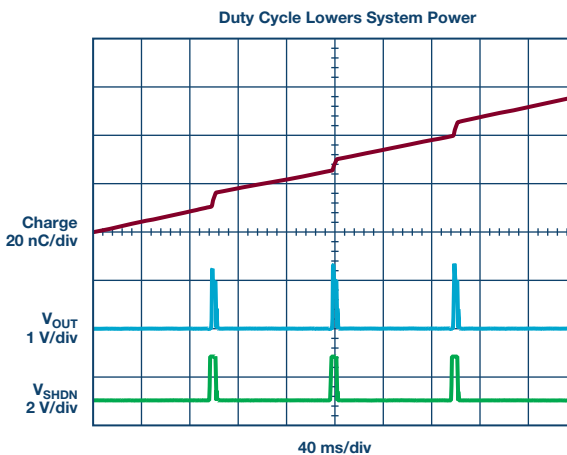

Zero-Drift Amplifiers

Part Number	Number of Amps	V_{OS} (max) (μ V)	$V_{OS,TC}$ (max) (μ V/ $^{\circ}$ C)	I_{BIAS} (max) (pA)	GBP (typ) (MHz)	Slew Rate (typ) (V/ μ s)	V_{NOISE} Density (typ) (nV/ \sqrt Hz)	0.1 Hz to 10 Hz V_{NOISE} (typ) (μ V p-p)	I_O /Amp (typ) (mA)	V_S Span (min) (V)	V_S Span (max) (V)	Package	ECCN Code
LTC2064 <i>New</i>	2	5	0.02	20	0.02	0.004	220	4.6	0.001	1.7	5.25	8-lead MSOP, 10-lead DFN	EAR99
LTC2066 <i>New</i>	1	5	0.02	35	0.1	0.018	80	1.7	0.008	1.7	5.25	5-lead SOT-23, 6-lead SC70	EAR99
LTC2067 <i>New</i>	2	5	0.02	35	0.1	0.018	80	1.7	0.008	1.7	5.25	8-lead MSOP, 10-lead DFN	EAR99
LTC2058 <i>New</i>	2	5	0.025	100	2.5	1.6	9	0.2	0.95	4.75	36	12-lead MSOP-EP, 8-lead SOIC-EP	EAR99
ADA4528-1	1	2.5	0.015	200	3.4	0.5	5.9	0.099	1.4	2.2	5.5	8-lead LFCSP, 8-lead MSOP	EAR99
ADA4528-2	2	2.5	0.015	250	3.4	0.5	5.9	0.099	1.4	2.2	5.5	8-lead LFCSP, 8-lead LFCSP, 8-lead MSOP	EAR99
LTC2050	1	3	0.03	75	3	2		1.5	0.8	2.7	6	8-lead SOIC, 5-lead SOT-23, 6-lead SOT-23	EAR99
LTC2050HV	1	3	0.03	75	3	2		1.5	0.8	2.7	11	8-lead SOIC, 5-lead SOT-23, 6-lead SOT-23	EAR99
LTC2051	2	3	0.03	75	3	2		1.5	0.85	2.7	6	8-lead SOIC, 8-lead MSOP, 10-lead MSOP, 8-lead DFN	EAR99
LTC2051HV	2	3	0.03	75	3	2		1.5	0.85	2.7	11	8-lead SOIC, 8-lead MSOP, 10-lead MSOP, 8-lead DFN	EAR99
LTC2052	4	3	0.03	75	3	2		1.5	0.85	2.7	6	14-lead SOIC, 16-lead SSOP	EAR99
LTC2052HV	4	3	0.03	75	3	2		1.5	0.85	2.7	11	14-lead SOIC, 16-lead SSOP	EAR99
LTC2054	1	3	0.03	150	0.5	0.5		1.6	0.14	2.7	6	5-lead SOT-23	EAR99
LTC2054HV	1	3	0.03	150	0.5	0.5		1.6	0.175	2.7	11	5-lead SOT-23	EAR99
LTC2055	2	3	0.03	150	0.5	0.5		1.6	0.13	2.7	6	8-lead MSOP, 8-lead DFN	EAR99
LTC2055HV	2	3	0.03	150	0.5	0.5		1.6	0.15	2.7	11	8-lead MSOP, 8-lead DFN	EAR99
LTC2057	1	4	0.015	200	1.5	1.2	11	0.2	0.8	4.75	36	8-lead SOIC, 8-lead MSOP, 10-lead MSOP, 8-lead DFN	EAR99
LTC2057HV	1	4	0.015	200	1.5	1.2	11	0.2	0.8	4.75	60	8-lead SOIC, 8-lead MSOP, 10-lead MSOP, 8-lead DFN	EAR99

Operational Amplifiers (Op Amps)

Zero-Drift Amplifiers (Continued)

Part Number	Number of Amps	V _{os} (max) (μV)	V _{os} TC (max) (μV/°C)	I _{BIAS} (max) (pA)	GBP (typ) (MHz)	Slew Rate (typ) (V/μs)	V _{NOISE} Density (typ) (nV/√Hz)	0.1 Hz to 10 Hz V _{NOISE} (typ) (μV p-p)	I _Q /Amp (typ) (mA)	V _s Span (min) (V)	V _s Span (max) (V)	Package	ECCN Code
ADA4638-1	1	4.5	0.8	90	1.5	1.5	66	1.2	0.85	4.5	30	8-lead LFCSP, 8-lead SOIC	EAR99
ADA4522-1	1	5	0.015	150	2.7	1.7	5.8	0.117	0.84	4.5	55	8-lead SOIC, 8-lead MSOP	EAR99
ADA4522-2	2	5	0.015	150	2.7	1.7	5.8	0.117	0.83	4.5	55	8-lead SOIC, 8-lead MSOP	EAR99
ADA4522-4	4	5	0.015	150	2.7	1.7	5.8	0.117	0.83	4.5	55	14-lead SOIC, 14-lead TSSOP	EAR99
AD8628	1	5	0.02	100	2.5	1	22	0.5	0.85	2.7	5.5	8-lead SOIC, 5-lead SOT-23, 5-lead TSOT	EAR99
AD8629	2	5	0.02	100	2.5	1	22	0.5	0.85	2.7	5.5	8-lead SOIC, 8-lead MSOP	EAR99
AD8630	4	5	0.02	300	2.5	1	22	0.5	0.85	2.7	5.5	14-lead SOIC, 14-lead TSSOP	EAR99
LTC2063	1	5	0.02	20	0.02	0.004	220	4.6	0.001	1.7	5.25	5-lead SOT-23, 6-lead SC70	EAR99
AD8551	1	5	0.04	50	1.5	0.4	42	1	0.975	2.7	5	8-lead SOIC, 8-lead MSOP	EAR99
AD8552	2	5	0.04	50	1.5	0.4	42	1	0.975	2.7	5	8-lead SOIC, 8-lead TSSOP	EAR99
AD8554	4	5	0.04	50	1.5	0.4	42	1	0.975	2.7	5	14-lead SOIC, 14-lead TSSOP	EAR99
AD8571	1	5	0.04	50	1.5	0.4	51	1.3	0.975	2.7	5.5	8-lead SOIC, 8-lead MSOP	EAR99
AD8572	2	5	0.04	50	1.5	0.4	51	1.3	0.975	2.7	5.5	8-lead SOIC, 8-lead TSSOP	EAR99
AD8574	4	5	0.04	50	1.5	0.4	51	1.3	0.975	2.7	5.5	14-lead SOIC, 14-lead TSSOP	EAR99
LTC1050	1	5	0.05	30	2.5	4	90	1.6	1	4.75	18	14-lead PDIP, 8-lead PDIP, 8-lead SOIC	EAR99
LTC1051	2	5	0.05	65	2.5	4	70	1.5	1	4.75	16.5	8-lead PDIP, 16-lead SOIC	EAR99
LTC1052	1	5	0.05	30	1.2	4	30	1.5	1.7	4.75	18	14-lead PDIP, 8-lead PDIP, 16-lead SOIC	EAR99
LTC1053	4	5	0.05	65	2.5	4	70	1.5	1	4.75	16.5	14-lead PDIP, 18-lead SOIC	EAR99
LTC1151	2	5	0.05	100	2	2.5		1.5	0.9	4.75	36	8-lead PDIP, 16-lead SOIC	EAR99
AD8638	1	9	0.06	75	1.5	2	60	1.2	1.5	4.5	16	8-lead SOIC, 5-lead SOT-23	EAR99
AD8639	2	9	0.06	75	1.5	2	60	1.2	1.5	4.5	16	8-lead LFCSP, 8-lead SOIC, 8-lead MSOP	EAR99
LTC1047	2	10	0.05	30	0.2	0.2		3.5	0.06	4.75	16	8-lead PDIP, 16-lead SOIC	EAR99
LTC1150	1	10	0.05	100	2.5	3		1.8	0.8	4.75	32	8-lead PDIP, 8-lead SOIC	EAR99
LTC1250	1	10	0.05	200	1.5	10	15	0.75	3	4.75	18	8-lead PDIP, 8-lead SOIC	EAR99
LTC1049	1	10	0.1	50	0.8	0.8	80	3	0.2	4.75	18	8-lead PDIP, 8-lead SOIC	EAR99
LTC1152	1	10	0.1	100	0.7	0.5	100	2	2.2	3	14	8-lead PDIP, 8-lead SOIC	EAR99
AD8538	1	13	0.1	25	0.43	0.4	50	2	0.18	2.7	5	8-lead SOIC, 5-lead TSOT	EAR99
AD8539	2	15	0.1	60	0.43	0.4	52	1.2	0.21	2.7	5	8-lead SOIC, 8-lead MSOP	EAR99
ADA4051-2	2	15	0.1	70	0.125	0.06	95	1.96	0.013	0	5	8-lead LFCSP, 8-lead MSOP	EAR99
ADA4051-1	1	17	0.1	70	0.125	0.06	95	1.96	0.015	0	5	5-lead SC70, 5-lead SOT-23	EAR99

Operational Amplifiers (Op Amps)

ADA4625-1: 36 V, 18 MHz, Low Noise, Fast Settling Single-Supply, RRO, JFET Op Amp**Key Features**

- ▶ Single-supply operation:
 - IVR includes negative supply rail
 - Rail-to-rail output maximizes dynamic range
- ▶ Low noise:
 - 3.3 nV/√Hz typ at 1 kHz
 - 0.15 μV p-p, 0.1 Hz to 10 Hz
- ▶ High speed: 18 MHz and 48 V/μs typ
- ▶ Settling time:
 - 0.5 μs to 0.1%, 0.7 μs to 0.01% (10 V step)
- ▶ Low V_{OS} and TCV_{OS} : ±80 μV max at 25°C and 1.2 μV/°C max
- ▶ Low I_{BIAS} current: 75 pA max at 25°C

Benefits

- ▶ 3 nV voltage noise enables increased sensitivity in transimpedance circuits
- ▶ Bandwidth/slew rate/settling time improves system throughput in multichannel DAQ systems
- ▶ Low I_{BIAS} and noise reduce PLL dynamic spurs
- ▶ Reduces phase jitter and dynamic spurs in PLL systems

Applications

- ▶ PLL filters
- ▶ Pulsed light photodiodes
- ▶ Data acquisition systems
- ▶ High speed instrumentation

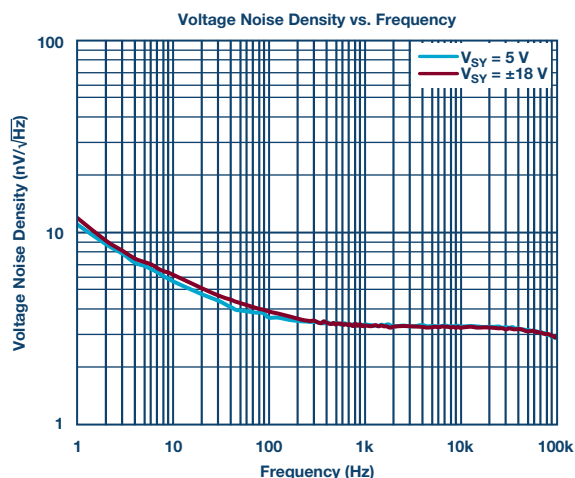
**Low Noise ($V_{NOISE} \leq 5 \text{ nV}/\sqrt{\text{Hz}}$) Amplifiers**

Part Number	Number of Amps	V_{NOISE} Density (typ) (nV/√Hz)	0.1 Hz to 10 Hz V_{NOISE} (typ) (μV p-p)	V_S Span (min) (V)	V_S Span (max) (V)	I_o /Amp (typ) (mA)	V_{OS} (max) (μV)	V_{OS} TC (max) (μV/°C)	I_{BIAS} (max) (nA)	GBP (typ) (MHz)	Slew Rate (typ) (V/μs)	Package	ECCN Code
ADA4625-1 <i>New</i>	1	3.3	0.15	5	36	4	80	2.1	0.075	18	48	8-lead SOIC-EP	EAR99
LTC2058 <i>New</i>	2	9	0.2	4.75	36	0.95	5	0.025	0.1	2.5	1.6	12-lead MSOP-EP, 8-lead SOIC-EP	EAR99
LT6274 <i>New</i>	1	10	1	9	32	1.6	400	10	500	40	2200	5-lead SOT-23	EAR99
LT1028	1	0.85	0.035	8	44	7.4	40	0.8	90	75	15	8-lead PDIP, 8-lead SOIC, 16-lead SOIC	EAR99
LT1128	1	0.85	0.035	8	44	7.4	40	0.8	90	20	6	8-lead PDIP, 8-lead SOIC	EAR99
ADA4898-2	2	0.9		9	36	7.9	125		400	50	55	8-lead SOIC-EP	EAR99
ADA4898-1	1	0.9		9	36	8.1	125		400	50	55	8-lead SOIC-EP	EAR99
LT1115	1	0.9		8	44	8.5	200		380	70	15	8-lead PDIP, 16-lead SOIC	EAR99
AD797	1	0.9	0.05	10	36	10.5	40	1	900	110	20	8-lead PDIP, 8-lead SOIC	EAR99
AD8099	1	0.95		5	12	15	500		13,000	3800	470	8-lead LFCSP, 8-lead SOIC-EP	EAR99
LT6200	1	0.95	0.6	2.5	12.6	20	1000	24	40,000	165	44	8-lead SOIC, 6-lead SOT-23	EAR99
LT6200-10	1	0.95	0.6	2.5	12.6	20	1000	24	40,000	1450	340	8-lead SOIC, 6-lead SOT-23	EAR99
LT6200-5	1	0.95	0.6	2.5	12.6	20	1000	24	40,000	750	210	8-lead SOIC, 6-lead SOT-23	EAR99
LT6201	2	0.95	0.6	2.5	12.6	20	1000	24	40,000	165	50	8-lead SOIC, 8-lead DFN	EAR99
ADA4895-1	1	1	0.099	3	10	3	350		6000	1500	943	8-lead SOIC, 6-lead SOT-23	EAR99
ADA4895-2	2	1	0.099	3	10	3	350		6000	1500	943	10-lead MSOP	EAR99
ADA4896-2	2	1	0.099	3	10	3	500		17,000	90	120	8-lead LFCSP, 8-lead MSOP	EAR99
ADA4897-1	1	1	0.099	3	10	3	500		17,000	90	120	8-lead SOIC, 6-lead SOT-23	EAR99

Operational Amplifiers (Op Amps)

Low Noise ($V_{\text{NOISE}} \leq 5 \text{ nV}/\sqrt{\text{Hz}}$) Amplifiers (Continued)

Part Number	Number of Amps	V_{NOISE} Density (typ) (nV/ $\sqrt{\text{Hz}}$)	0.1 Hz to 10 Hz V_{NOISE} (typ) ($\mu\text{V p-p}$)	V_s Span (min) (V)	V_s Span (max) (V)	I_q /Amp (typ) (mA)	V_{OS} (max) (μV)	V_{OS} TC (max) ($\mu\text{V}/^\circ\text{C}$)	I_{BIAS} (max) (nA)	GBP (typ) (MHz)	Slew Rate (typ) (V/ μs)	Package	ECCN Code
ADA4897-2	2	1	0.099	3	10	3	500		17,000	90	120	Chips or die, 10-lead MSOP	EAR99
ADA4899-1	1	1		4.5	12	14.7	230		1000	280	310	8-lead LFCSP, 8-lead SOIC-EP	EAR99
AD8597	1	1.07	0.076	9	30	5.7	120	2.2	200	10	16	8-lead LFCSP, 8-lead SOIC	EAR99
AD8599	2	1.07	0.076	9	36	5.7	120	2.2	200	10	16	8-lead SOIC	EAR99
LT6236	1	1.1	0.18	3	12.6	3.15	500	2	10,000	215	60	6-lead SOT-23	EAR99
LT6237	2	1.1	0.18	3	12.6	3.15	500	2	10,000	215	60	8-lead MSOP, 8-lead DFN	EAR99
LT6238	4	1.1	0.18	3	12.6	3.15	500	2	10,000	215	60	16-lead SSOP	EAR99
LT6230	1	1.1	0.18	3	12.6	3.3	500	3	10,000	215	70	6-lead SOT-23	EAR99
LT6230-10	1	1.1	0.18	3	12.6	3.3	500	3	10,000	1450	250	6-lead SOT-23	EAR99
LT6231	2	1.1	0.18	3	12.6	3.3	350	3	10,000	215	70	8-lead SOIC, 8-lead DFN	EAR99
LT6232	4	1.1	0.18	3	12.6	3.3	350	3	10,000	215	70	16-lead SSOP	EAR99
LT6018	1	1.2	0.03	8	33	7.2	50	0.5	150	15	30	8-lead SOIC-EP, 12-lead DFN	EAR99
ADA4800	1	1.5		4	17	1.4	41,000		0	0	415	6-lead LFCSP, chips or die	EAR99
AD8004	4	1.5		4	12	14	3500		110,000	250	3000	14-lead SOIC	EAR99
AD8000	1	1.6	0.02	4.5	12	13.5	10,000		45,000	0	4100	8-lead LFCSP, 8-lead SOIC-EP	EAR99
AD829	1	1.7		9	36	5.3	1000		7000	750	230	20-lead LCC, 8-lead PDIP, 8-lead CerDIP, 8-lead SOIC, chips or die	EAR99
LT1993-10	1	1.7		4	5.5	100	6500		0	700	1100	16-lead QFN	EAR99
ADA4004-1	1	1.8	0.15	10	30	2.2	125	1	90	12	2.7	8-lead SOIC, 5-lead SOT-23	EAR99
ADA4004-2	2	1.8	0.15	10	30	2.2	125	1	90	12	2.7	8-lead SOIC, 8-lead MSOP	EAR99
ADA4004-4	4	1.8	0.15	10	30	2.2	125	1	90	12	2.7	16-lead LFCSP, 14-lead SOIC	EAR99
AD8003	3	1.8		4.5	10	9.5	9300		50,000	1650	3800	24-lead LFCSP, chips or die	EAR99
AD815	2	1.85		10	36	15	8000		5000	0	900		EAR99
LT6233	1	1.9	0.22	3	12.6	1.15	500	3	3000	60	15	6-lead SOT-23	EAR99
LT6233-10	1	1.9	0.22	3	12.6	1.15	500	3	3000	375	80	6-lead SOT-23	EAR99
LT6234	2	1.9	0.22	3	12.6	1.15	350	3	3000	60	17	8-lead SOIC, 8-lead DFN	EAR99
LT6235	4	1.9	0.22	3	12.6	1.15	350	3	3000	60	17	16-lead SSOP	EAR99
LT6202	1	1.9	0.8	2.5	12.6	2.8	500	24	7000	100	25	8-lead SOIC, 5-lead SOT-23	EAR99
LT6203	2	1.9	0.8	2.5	12.6	2.8	500	24	7000	100	25	8-lead SOIC, 8-lead MSOP, 8-lead DFN	EAR99
LT6204	4	1.9	0.8	2.5	12.6	2.8	500	24	7000	100	25	14-lead SOIC, 16-lead SSOP	EAR99
AD8017	2	1.9		4.4	12	7	3000		45,000	0	1600	8-lead SOIC	EAR99
AD8009	1	1.9		5	12	14	5000		150,000	0	5500	8-lead SOIC, 5-lead SOT-23, chips or die	EAR99
AD811	1	1.9		9	36	14.5	3000		5000	0	400	20-lead LCC, 8-lead PDIP, 8-lead CerDIP, 8-lead SOIC, 16-lead SOIC—wide, LCC:cer leadless chip carr, chips or die	EAR99
AD8011	1	2		3	12	1	5000		15,000	0	1100	8-lead PDIP, 8-lead SOIC	EAR99
LT6203X	2	2	0.8	2.5	12.6	3.3	500		7000	83	24	8-lead SOIC	EAR99
AD8001	1	2		6	12	5	5500		25,000	880	1200	8-lead PDIP, 8-lead CerDIP, 8-lead SOIC, 5-lead SOT-23, chips or die	EAR99
AD8023	3	2		4.2	15	6.2	5000		45,000	0	1200	14-lead SOIC, chips or die	EAR99
AD844	1	2		9	36	6.5	150		250	0	2000	8-lead PDIP, 8-lead CerDIP 16-lead SOIC—wide, chips or die	EAR99
AD8002	2	2		6	12	10	6000		25,000	600	1200	8-lead SOIC, 8-lead MSOP	EAR99
AD8079	2	2		6	12	10	15,000		6000	260	800	8-lead SOIC	EAR99
AD8010	1	2		9	12	15.5	12,000		135,000	0	800	8-lead PDIP, 8-lead SOIC, 16-lead SOIC—wide	EAR99

Operational Amplifiers (Op Amps)

Low Noise ($V_{\text{NOISE}} \leq 5 \text{ nV}/\sqrt{\text{Hz}}$) Amplifiers (Continued)

Part Number	Number of Amps	V_{NOISE} Density (typ) (nV/ $\sqrt{\text{Hz}}$)	0.1 Hz to 10 Hz V_{NOISE} (typ) (μV p-p)	V_{S} Span (min) (V)	V_{S} Span (max) (V)	$I_{\text{O/Amp}}$ (typ) (mA)	V_{OS} (max) (μV)	V_{OS} TC (max) ($\mu\text{V}/^{\circ}\text{C}$)	I_{BIAS} (max) (nA)	GBP (typ) (MHz)	Slew Rate (typ) (V/ μs)	Package	ECCN Code
ADA4841-1	1	2.1		2.7	12	1.2	300		5300	35	13	8-lead SOIC, 6-lead SOT-23	EAR99
ADA4841-2	2	2.1		2.7	12	1.2	300		5300	35	13	8-lead LFCSP, 8-lead SOIC, 8-lead MSOP, chips or die	EAR99
AD8021	1	2.1		4.5	24	7.8	1000		11,300	1000	130	8-lead SOIC, 8-lead MSOP	EAR99
ADA4870	1	2.1		10	40	32.5	10,000		23,000	0	2500	PSOP_3 430 mil with heatsink, chips or die	EAR99
LT1993-4	1	2.15		4	5.5	100	6500		0	900	1100	16-lead QFN	EAR99
LTC6360	1	2.3		4.75	5.25	13.6	250		30,000	1000	135	8-lead MSOP-EP, 8-lead DFN	EAR99
ADA4311-1	2	2.4		12	12	11.8	3000		16,000	0	1050	10-lead MSOP_ED	EAR99
AD8012	2	2.5		3	12	1.7	4000		12,000	0	2250	8-lead SOIC, 8-lead MSOP	EAR99
LT1007	1	2.5	0.06	4	44	2.6	25	0.6	35	8	2.5	8-lead PDIP, 8-lead SOIC	EAR99
LT1037	1	2.5	0.06	8	44	2.6	25	0.6	35	60	15	8-lead PDIP, 8-lead SOIC	EAR99
AD8022	2	2.5		4.5	26	4	6000		5000	100	50	8-lead SOIC, 8-lead MSOP	EAR99
AD8392A		2.5		10	24	5.8	4000		10,000	0	515	32-lead LFCSP with 3.1 mm exposed pad, 28-lead TSSOP-EP	EAR99
LT1226	1	2.6		5	36	7	1000		8000	1000	400	8-lead PDIP, 8-lead SOIC	EAR99
AD8016	2	2.6		6	26	12.5	3000		75,000	0	1000	28-lead TSSOP-EP	EAR99
LT1124	2	2.7	0.07	8	44	2.3	70	1	20	12.5	4.5	8-lead PDIP, 8-lead SOIC	EAR99
LT1125	4	2.7	0.07	8	44	2.3	90	1	20	12.5	4.5	14-lead PDIP, 16-lead SOIC	EAR99
LT1126	2	2.7	0.07	8	44	2.6	70	1	20	65	11	8-lead PDIP, 8-lead SOIC	EAR99
LT1127	4	2.7	0.07	8	44	2.6	90	1	20	65	11	14-lead PDIP, 16-lead SOIC	EAR99
AD8655	1	2.7		2.7	5.5	4.5	250	2.3	0.01	28	11	8-lead SOIC, 8-lead MSOP	EAR99
AD8656	2	2.7		2.7	5.5	4.5	250	2.3	0.01	28	11	8-lead SOIC, 8-lead MSOP	EAR99
AD8007	1	2.7		5	12	9	4000		6000	0	1000	5-lead SC70, 8-lead SOIC	EAR99
AD8008	2	2.7		5	12	9	4000		8000	380	1000	8-lead SOIC, 8-lead MSOP	EAR99
LT1251	1	2.7		5	36	13.5	5000		30,000	40	300	14-lead PDIP, 14-lead SOIC	EAR99
LT1256	1	2.7		5	36	13.5	5000		0	40	300	14-lead PDIP, 14-lead SOIC	EAR99
LTC6252	1	2.75	2	2.5	5.25	3.3	350		3000	720	280	6-lead SOT-23	EAR99
LTC6253	2	2.75	2	2.5	5.25	3.3	350		3000	720	280	8-lead SOT-23, 8-lead MSOP, 10-lead MSOP, 8-lead DFN	EAR99
LTC6253-7	2	2.75	2	2.5	5.25	3.3	350		750	2000	500	10-lead MSOP	EAR99
LTC6254	4	2.75	2	2.5	5.25	3.3	350		3000	720	280	16-lead MSOP	EAR99
ADA4075-2	2	2.8	0.06	9	36	2.25	1000		100	6.5	12	8-lead LFCSP, 8-lead SOIC	EAR99
AD8675	1	2.8	0.1	10	30	2.9	75	0.6	2	10	2.5	8-lead SOIC, 8-lead MSOP	EAR99
AD8676	2	2.8	0.1	10	30	2.9	50	0.6	2	10	2.5	8-lead SOIC, 8-lead MSOP	EAR99
AD8671	1	2.8	0.077	8	36	3.5	75	0.5	12	10	4	8-lead SOIC, 8-lead MSOP	EAR99
AD8672	2	2.8	0.077	8	36	3.5	75	0.8	12	10	4	8-lead SOIC, 8-lead MSOP	EAR99
AD8674	4	2.8	0.077	8	36	3.5	75	0.8	12	10	4	14-lead SOIC, 14-lead TSSOP	EAR99
ADA4310-1	2	2.85		5	12	7.6			0	0	820	16-lead LFCSP, 10-lead MSOP_ED	EAR99
AD810	1	2.9		5	36	6.8	6000		10,000	80	1000	8-lead PDIP, 8-lead CerDIP, 8-lead SOIC, chips or die	EAR99
AD743	1	2.9	0.38	9.6	36	10	1000		0.4	4.5	2.8	16-lead SOIC—wide	EAR99
AD745	1	2.9	0.38	9.6	36	10	500		0.25	20	12.5	16-lead SOIC—wide	EAR99
AD8072	2	3		5	12	3	6000		12,000	100	500	8-lead PDIP, 8-lead SOIC, 8-lead MSOP	EAR99
AD8073	3	3		5	12	3	6000		12,000	100	500	14-lead SOIC	EAR99
LT1253	2	3		4	28	6	15,000		0	250	250	8-lead PDIP, 8-lead SOIC	EAR99
LT1254	4	3		4	28	6	15,000		0	250	250	14-lead PDIP, 14-lead SOIC	EAR99
LT1497	2	3		4	36	6	15,000		0	59	900	16-lead SOIC, 8-lead SOIC	EAR99
LT1222	1	3		5	36	8	300		300	500	200	8-lead PDIP, 8-lead SOIC	EAR99
LT1252	1	3		4	28	8.5	15,000		0	250	250	8-lead PDIP, 8-lead SOIC	EAR99
LT1994	1	3		2.375	12.6	13.3	2000		45,000	70	65	8-lead MSOP, 8-lead DFN	EAR99

Operational Amplifiers (Op Amps)

Low Noise ($V_{\text{NOISE}} \leq 5 \text{ nV}/\sqrt{\text{Hz}}$) Amplifiers (Continued)

Part Number	Number of Amps	V_{NOISE} Density (typ) (nV/ $\sqrt{\text{Hz}}$)	0.1 Hz to 10 Hz V_{NOISE} (typ) ($\mu\text{V p-p}$)	V_s Span (min) (V)	V_s Span (max) (V)	I_q /Amp (typ) (mA)	V_{OS} (max) (μV)	V_{OS} TC (max) ($\mu\text{V}/^\circ\text{C}$)	I_{BIAS} (max) (nA)	GBP (typ) (MHz)	Slew Rate (typ) (V/ μs)	Package	ECCN Code
AD8045	1	3		3.3	12	16	1000		6300	400	1350	8-lead LFCSP, 8-lead SOIC-EP	EAR99
AD8024	4	3		5	24	17	5000		7500	200	390	16-lead SOIC	EAR99
LT1210	1	3		8	36	35	15,000		0	66	900	7-lead TO-220 (flow 06) round header/metal CAN, 7-lead DD PAK, 7-lead TO-220 (flow 44), 7-lead TO-220 (flow 37), 16-lead SOIC	EAR99
LT1210X	1	3		10	30	35	15,000		0	66	900	16-lead TSSOP-EP	EAR99
LT1677	1	3.2	0.09	2.5	44	2.75	60	1.5	20	7.2	2.5	8-lead PDIP, 8-lead SOIC	EAR99
LT1229	2	3.2		4	36	6	10,000		0	100	700	8-lead PDIP, 8-lead SOIC	EAR99
LT1230	4	3.2		4	36	6	10,000		0	100	700	14-lead PDIP, 14-lead SOIC	EAR99
LT1227	1	3.2		4	36	10	10,000		0	140	1100	8-lead PDIP, 8-lead SOIC	EAR99
LT1227MJ8	1	3.2		4	36	10	10,000		0	100	1100	8-lead PDIP, 8-lead SOIC	EAR99
ADA4861-3	3	3.2		5	12	16.1	13,000		13,000	730	680	14-lead SOIC	EAR99
ADA4807-1	1	3.3	0.16	2.7	11	1	125	3.7	1600	200	225	6-lead SC70, 6-lead SOT-23	EAR99
ADA4807-2	2	3.3	0.16	2.7	11	1	125	3.7	1600	200	225	10-lead LFCSP, 8-lead MSOP	EAR99
ADA4807-4	4	3.3	0.16	2.7	11	1	175	3.7	1600	200	225	14-lead TSSOP	EAR99
AD8014	1	3.5		4.5	12	1.15	5000		15,000	0	4600	8-lead SOIC, 5-lead SOT-23	EAR99
AD8013	3	3.5		4.2	13	3.5	5000		15,000	140	1000	14-lead SOIC, chips or die	EAR99
AD812	2	3.5		2.4	36	4.5	5000		25,000	0	250	8-lead PDIP, 8-lead SOIC	EAR99
AD813	3	3.5		2.4	36	4.5	5000		30,000	0	450	14-lead PDIP, 14-lead SOIC, chips or die, LCC:cer leadless chip carr	EAR99
LT1806	1	3.5	0.8	2.5	12.6	9	550	5	4000	325	125	8-lead SOIC, 6-lead SOT-23	EAR99
LT1807	2	3.5	0.8	2.5	12.6	9	550	5	4000	325	125	8-lead SOIC, 8-lead MSOP	EAR99
LT1993-2	1	3.5		4	5.5	100	6500		0	800	1100	16-lead QFN	EAR99
LT1206	1	3.6		10	36	20	10,000		0	66	900	Round header/metal CAN 7-lead DD PAK, 8-lead PDIP, 8-lead SOIC	EAR99
LT1207	2	3.6		10	36	20	10,000		0	66	900	16-lead SOIC	EAR99
LT1259	2	3.6		4	36	5	12,000		0	130	1600	14-lead PDIP, 14-lead SOIC	EAR99
LT1260	3	3.6		4	36	5	12,000		0	130	1600	16-lead PDIP, 16-lead SOIC	EAR99
LT1795	2	3.6		10	36	29	13,000		0	65	900	20-lead SOIC, 20-lead TSSOP-EP	EAR99
AD8048	1	3.8		6	12	5.9	3000		3500	120	1000	8-lead SOIC	EAR99
LT1722	1	3.8		4.6	12.6	3.7	400	7	300	200	70	8-lead SOIC, 5-lead SOT-23	EAR99
LT1723	2	3.8		4.6	12.6	3.7	400	7	300	200	70	8-lead SOIC, 8-lead MSOP	EAR99
LT1724	4	3.8		4.6	12.6	3.7	400	7	300	200	70	14-lead SOIC	EAR99
ADA4084-1	1	3.9	0.1	3	30	0.625	100	1.75	250	15.9	4.6	8-lead SOIC, 5-lead SOT-23	EAR99
ADA4084-2	2	3.9	0.1	3	30	0.625	100	1.75	250	15.9	4.6	8-lead LFCSP, 8-lead SOIC, 8-lead MSOP	EAR99
ADA4084-4	4	3.9	0.1	3	30	0.625	100	1.75	250	15.9	4.6	16-lead LFCSP, 14-lead TSSOP	EAR99
LT1678	2	3.9	0.09	3	36	2	100	3	20	20	6	8-lead SOIC	EAR99
LT1679	4	3.9		3	36	2	100	3	20	20	6	14-lead SOIC	EAR99
AD8005	1	4		8	12	0.4	30,000		10,000	270	1500	8-lead SOIC, 5-lead SOT-23	EAR99
ADA4817-1	1	4		5	10	19	2000		0.02	410	870	8-lead LFCSP, 8-lead SOIC-EP	EAR99
ADA4817-2	2	4		5	10	19	2000		0.02	410	870	16-lead LFCSP	EAR99
ADA4858-3	3	4		3	5.5	19	14,000		13,000	600	600	16-lead LFCSP	EAR99
ADA4860-1	1	4		5	12	6	13,000		10,000	0	790	6-lead SOT-23	EAR99
LTC6268-10	1	4	12.6	3.1	5.25	16.5	700		0.00002	4000	1500	8-lead SOIC, 6-lead SOT-23	EAR99

Operational Amplifiers (Op Amps)

Low Noise ($V_{\text{NOISE}} \leq 5 \text{ nV}/\sqrt{\text{Hz}}$) Amplifiers (Continued)

Part Number	Number of Amps	V_{NOISE} Density (typ) (nV/ $\sqrt{\text{Hz}}$)	0.1 Hz to 10 Hz V_{NOISE} (typ) ($\mu\text{V p-p}$)	V_{S} Span (min) (V)	V_{S} Span (max) (V)	$I_{\text{O/Amp}}$ (typ) (mA)	V_{OS} (max) (μV)	V_{OS} TC (max) ($\mu\text{V}/^{\circ}\text{C}$)	I_{BIAS} (max) (nA)	GBP (typ) (MHz)	Slew Rate (typ) (V/ μs)	Package	ECCN Code
LTC6269-10	2	4	12.6	3.1	5.25	16.5	700		0.00002	4000	1500	8-lead MSOP-EP, 10-lead DFN	EAR99
AD8634	2	4.2	0.13	3	30	1.1	250		200	9.7	5	Chips or die, 8-lead flatpack, 8-lead SOIC	EAR99
LT1792	1	4.2	2.4	10	40	4.2	600	10	0.8	5.6	3.4	8-lead PDIP, 8-lead SOIC	EAR99
LTC6246	1	4.2		2.5	5.25	0.95	500		350	180	90	6-lead SOT-23	EAR99
LTC6247	2	4.2		2.5	5.25	0.95	500		350	180	90	8-lead SOT-23, 8-lead MSOP, 10-lead MSOP, 8-lead DFN	EAR99
LTC6248	4	4.2		2.5	5.25	0.95	500		350	180	90	16-lead MSOP	EAR99
AD8027	1	4.3		2.7	12	6.5	900		6000	190	100	8-lead SOIC, 6-lead SOT-23	EAR99
AD8028	2	4.3		2.7	12	6.5	900		6000	190	100	Chips or die, 8-lead SOIC, 10-lead MSOP	EAR99
AD9632	1	4.3		6	12	16	5000		7000	130	1500	8-lead SOIC	EAR99
LTC6268	1	4.3	13	3.1	5.25	16.5	700		0.00002	500	400	8-lead SOIC, 6-lead SOT-23	EAR99
LTC6269	2	4.3	13	3.1	5.25	16.5	700		0.00002	500	400	8-lead SOIC, 6-lead SOT-23	EAR99
ADA4857-1	1	4.4		4.5	10.5	5	4500	22	3300	410	2800	8-lead LFCSP, 8-lead SOIC	EAR99
ADA4857-2	2	4.4		4.5	10.5	5	4500	22	3300	410	2800	16-lead LFCSP	EAR99
AD8018	2	4.5		3.3	8	9	15,000		8000	0	300	8-lead SOIC, 14-lead TSSOP	EAR99
AD8037	1	4.5		6	12	18.5	7000		9000	140	1500	8-lead SOIC, chips or die	EAR99
AD8397	2	4.5		3	25.2	11	3000		900	35	53	8-lead SOIC, 8-lead SOIC-EP	EAR99
AD8651	1	4.5		2.7	5.5	9	350		0.01	50	41	8-lead SOIC, 8-lead MSOP	EAR99
AD8652	2	4.5		2.7	5.5	9	300		0.01	50	41	8-lead SOIC, 8-lead MSOP	EAR99
LT1113	2	4.5	2.4	9	40	5.3	1500	1.5	0.45	5.6	3.9	8-lead PDIP, 8-lead SOIC	EAR99
LT1395	1	4.5		3	12.6	4.6	12,000		0	400	800	8-lead SOIC, 5-lead SOT-23, 6-lead SOT-23	EAR99
LT1396	2	4.5		3	12.6	4.6	12,000		0	400	800	8-lead SOIC, 8-lead MSOP, 8-lead DFN	EAR99
LT1397	4	4.5		3	12.6	4.6	12,000		0	400	800	14-lead SOIC, 16-lead SSOP, 14-lead DFN	EAR99
LT1398	2	4.5		3	12.6	4.6	12,000		0	300	800	16-lead SOIC	EAR99
LT1399	3	4.5		3	12.6	4.6	12,000		0	300	800	16-lead SOIC, 16-lead SSOP	EAR99
LT1399HV	3	4.5		3	15.5	4.6	12,000		0	300	800	16-lead SOIC, 16-lead SSOP	EAR99
LT6559	3	4.5		4	12	3.9	10,000		0	300	500	16-lead QFN	EAR99
ADA4627-1	1	4.8	0.7	9	36	7	200	2	0.005	19	56	8-lead LFCSP, 8-lead SOIC	EAR99
ADA4637-1	1	4.8	0.7	9	30	7	200	2	0.005	79.9	170	8-lead LFCSP, 8-lead SOIC	EAR99
AD848	1	5		9	36	4.8	2300		5000	175	300	8-lead PDIP, 8-lead CerDIP, 8-lead SOIC, chips or die	EAR99
ADA4350	1	5		3.3	12	8.5	80	1.6	0.001	175	100	28-lead TSSOP	EAR99
LT1468	1	5	0.3	6	36	3.6	75	2	40	90	22	8-lead PDIP, 8-lead SOIC, 8-lead DFN	EAR99
LT1468-2	1	5	0.3	10	36	3.9	75		10	200	30	8-lead SOIC, 8-lead DFN	EAR99
LT1469	2	5	0.3	6	36	4.1	125	3	40	90	22	8-lead PDIP, 8-lead SOIC, 12-lead DFN	EAR99
LT1469-2	2	5	0.3	10	36	4.1	125		10	200	30	8-lead SOIC, 12-lead DFN	EAR99

Operational Amplifiers (Op Amps)

Low Power ($I_O/\text{Amp} < 0.5 \text{ mA}$) Amplifiers

Part Number	Number of Amps	I_O/Amp (typ) (μA)	Shut-down	GBP (typ) (MHz)	Slew Rate (typ) (V/ μs)	I_{BIAS} (max) (nA)	V_{OS} (max) (μV)	V_{NOISE} Density (typ) (nV/ $\sqrt{\text{Hz}}$)	0.1 Hz to 10 Hz V_{NOISE} (typ) (μV p-p)	V_s Span (min) (V)	V_s Span (max) (V)	Package	ECCN Code
LTC2064 <i>New</i>	2	1.4	Yes	0.02	0.004	0.02	5	220	4.6	1.7	5.25	8-lead MSOP, 10-lead DFN	EAR99
LTC2066 <i>New</i>	1	7.5	Yes	0.1	0.018	0.035	5	80	1.7	1.7	5.25	5-lead SOT-23, 6-lead SC70	EAR99
LTC2067 <i>New</i>	2	7.5	Yes	0.1	0.018	0.035	5	80	1.7	1.7	5.25	8-lead MSOP, 10-lead DFN	EAR99
LTC6260 <i>New</i>	4	20	No	14.3	0.24	75	400	38	2	1.8	5.25	10-lead MSOP	EAR99
LT1997-2 <i>New</i>	1	350	Yes	11	0.75	5	80	37	0.9	3.3	50	16-lead MSOP (4 pins removed), 14-lead DFN	EAR99
AD8500	1	0.75	No	0.077	0.004	0.01	1000	190		1.8	5	5-lead SC70	EAR99
AD8502	2	0.75	No	0.077	0.004	0.01	3000	190	6	1.8	5	8-lead SOT-23	EAR99
AD8504	4	0.75	No	0.077	0.004	0.01	3000	190	6	1.8	5	14-lead TSSOP	EAR99
LT6003	1	0.85	No	0.022	0.001	0.09	500	325	3	1.6	16	5-lead SOT-23, 4-lead DFN	EAR99
LT6004	2	0.85	No	0.022	0.001	0.09	500	325	3	1.6	16	8-lead MSOP, 8-lead DFN	EAR99
LT6005	4	0.85	No	0.022	0.001	0.09	650	325	3	1.6	16	16-lead SSOP, 16-lead DFN	EAR99
LT1494	1	1	No	0.030	0.001	1	375	185	4	2.1	36	8-lead PDIP, 8-lead SOIC, 8-lead MSOP	EAR99
LT1495	2	1	No	0.030	0.001	1	375	185	4	2.1	36	8-lead PDIP, 8-lead SOIC	EAR99
LT1496	4	1	No	0.030	0.001	1	375	185	4	2.1	36	14-lead PDIP, 14-lead SOIC	EAR99
LTC2063	1	1.4	Yes	0.02	0.004	0.02	5	220	4.6	1.7	5.25	5-lead SOT-23, 6-lead SC70	EAR99
LT1672	1	1.5	No	0.132	0.005	1	375	185	4	2.1	36	8-lead PDIP, 8-lead SOIC, 8-lead MSOP	EAR99
LT1673	2	1.5	No	0.132	0.005	1	375	185	4	2.1	36	8-lead PDIP, 8-lead SOIC	EAR99
LT1674	4	1.5	No	0.132	0.005	1	375	185	4	2.1	36	14-lead PDIP, 14-lead SOIC	EAR99
ADA4505-1	1	9	No	0.55	0.006	0.002	3000	65	2.95	1.8	5	6-ball WLCSP, 5-lead SOT-23	EAR99
ADA4505-2	2	9	No	0.55	0.006	0.002	3000	65	2.95	1.8	5	8-ball WLCSP, 8-lead MSOP	EAR99
ADA4505-4	4	9	No	0.55	0.006	0.002	3000	65	2.95	1.8	5	14-ball WLCSP, 14-lead TSSOP	EAR99
LT1178	2	12	No	0.935	0.04	5	70	49	0.9	2	44	8-lead PDIP, 8-lead SOIC, 16-lead SOIC	EAR99
LT1179	4	12	No	0.935	0.04	5	100	49	0.9	2	44	14-lead PDIP, 16-lead SOIC	EAR99
ADA4051-2	2	13	No	1.375	0.06	0.07	15	95	1.96	0	5	8-lead LFCSP, 8-lead MSOP	EAR99
LT2178	2	13	No	0.66	0.025	5	70	49	0.9	2.2	44	8-lead SOIC	EAR99
LT2179	4	13	No	0.66	0.025	5	100	49	0.9	2.2	44	14-lead SOIC	EAR99
LT6000	1	13	Yes	0.55	0.015	5	750	75		1.8	18	6-lead DFN	EAR99
LT6001	2	13	Yes	0.55	0.015	5	600	75		1.8	18	8-lead MSOP, 10-lead DFN	EAR99
LT6002	4	13	No	0.55	0.015	5	750	75		1.8	18	16-lead SSOP, 16-lead DFN	EAR99
ADA4051-1	1	15	No	1.375	0.06	0.07	17	95	1.96	0	5	5-lead SC70, 5-lead SOT-23	EAR99
AD8505	1	16.5	No	1.045	0.013	0.01	2500	45	2.8	1.8	5	6-ball WLCSP, 5-lead SOT-23	EAR99
LT6023	2	18	No	0.44	1.45	3	30	132		3	30	8-lead MSOP, 8-lead DFN, 10-lead DFN	EAR99
LT6023-1	2	18	Yes	0.44	1.45	3	30	132		3	30	8-lead MSOP, 8-lead DFN, 10-lead DFN	EAR99
AD8506	2	20	No	1.045	0.013	0.01	2500	45	2.8	1.8	5	8-ball WLCSP, 8-lead MSOP	EAR99
LTC6258	1	20	Yes	14.3	0.24	75	400	38	2	1.8	5.25	6-lead SOT-23, 6-lead DFN	EAR99
LTC6259	2	20	Yes	14.3	0.24	75	400	38	2	1.8	5.25	8-lead SOT-23, 8-lead MSOP, 10-lead MSOP, 8-lead DFN	EAR99
AD8657	2	22	No	2.53	0.08	0.02	350	45	5	2.7	18	8-lead LFCSP, 8-lead MSOP	EAR99
AD8659	4	22	No	2.53	0.08	0.02	350	45	5	2.7	18	16-lead LFCSP, 14-lead SOIC	EAR99
LT1462	2	28	No	1.925	0.13	0.002	800	76	2	10	40	8-lead PDIP, 8-lead SOIC	EAR99
LT1463	4	28	No	1.925	0.13	0.002	800	76	2	10	40	14-lead PDIP, 14-lead SOIC	EAR99
LT2078	2	35	No	2.2	0.07	8	70	28	0.6	2.3	44	8-lead SOIC	EAR99
LT2079	4	35	No	2.2	0.07	8	110	28	0.6	2.3	44	14-lead SOIC	EAR99
AD8613	1	38	No	3.85	0.1	0.001	2200	22	2.3	1.8	5	5-lead SC70, 5-lead TSOT	EAR99
AD8617	2	38	No	4.4	0.1	0.001	2200	22	2.3	1.8	5	8-lead LFCSP, 8-lead SOIC, 8-lead MSOP	EAR99
AD8619	4	38	No	4.4	0.1	0.001	2200	22	2.3	1.8	5	14-lead SOIC, 14-lead TSSOP	EAR99
LT1078	2	38	No	2.2	0.07	8	70	28	0.6	2.2	44	8-lead PDIP, 8-lead SOIC, 16-lead SOIC	EAR99
LT1079	4	38	No	2.2	0.07	8	100	28	0.6	2.2	44	14-lead PDIP, 16-lead SOIC	EAR99
LT1079MJ	4	38	No	2.2	0.07	8	100	28	0.6	2.2	44	14-lead PDIP, 16-lead SOIC	EAR99
AD8609	4	40	No	3.476	0.1	0.001	300	22	2.3	1.8	5	14-lead SOIC, 14-lead TSSOP	EAR99
LT1490A	2	40	No	1.98	0.06	8	500	50	1	2	44	8-lead PDIP, 8-lead SOIC, 8-lead MSOP, 8-lead DFN	EAR99
LT1491A	4	40	No	1.98	0.06	8	1000	50	1	2	44	14-lead PDIP, 14-lead SOIC, 16-lead DFN	EAR99
LT1782	1	40	Yes	2.2	0.07	15	800	50	1	2.2	18	5-lead SOT-23, 6-lead SOT-23	EAR99
LT1636	1	42	Yes	2.2	0.07	8	225	52	0.7	2.6	44	8-lead PDIP, 8-lead SOIC, 8-lead MSOP, 8-lead DFN	EAR99
LT1077	1	48	No	2.53	0.08	9	40	27	0.5	2.2	44	8-lead PDIP, 8-lead SOIC	EAR99
AD8603	1	50	No	3.476	0.1	0.001	300	22	2.3	1.8	5	5-lead TSOT	EAR99
AD8607	2	50	No	3.476	0.1	0.001	300	22	2.3	1.8	5	8-lead SOIC, 8-lead MSOP	EAR99

Operational Amplifiers (Op Amps)

Low Power ($I_Q/\text{Amp} < 0.5 \text{ mA}$) Amplifiers (Continued)

Part Number	Number of Amps	I_Q/Amp (typ) (μA)	Shut-down	GBP (typ) (MHz)	Slew Rate (typ) (V/ μs)	I_{BIAS} (max) (nA)	V_{OS} (max) (μV)	V_{NOISE} Density (typ) (nV/ $\sqrt{\text{Hz}}$)	0.1 Hz to 10 Hz V_{NOISE} (typ) ($\mu\text{V p-p}$)	V_s Span (min) (V)	V_s Span (max) (V)	Package	ECCN Code
LTC6078	2	54	Yes	8.25	0.05	0.001	25	18	1	2.7	5.5	8-lead MSOP, 10-lead DFN	EAR99
LTC6079	4	54	No	8.25	0.05	0.001	25	18	1	2.7	5.5	16-lead SSOP, 16-lead DFN	EAR99
ADA4096-2	2	60	No	8.646	0.4	25	300	27	0.7	3	30	8-lead LFCSP, 8-lead MSOP	EAR99
ADA4096-4	4	60	No	8.646	0.4	25	300	27	0.7	3	30	16-lead LFCSP, 14-lead TSSOP	EAR99
LT1466L	2	60	No	1.32	0.04	14	390	45		2	16	8-lead PDIP, 8-lead SOIC	EAR99
LT1467L	4	60	No	1.32	0.04	14	390	45		2	16	16-lead SOIC	EAR99
LTC1047	2	60	Yes	2.2	0.2	0.03	10		3.5	4.75	16	8-lead PDIP, 16-lead SOIC	EAR99
LTC6255	1	60	Yes	71.5	1.8	50	350	21	2.5	1.8	5.25	6-lead SOT-23, 6-lead DFN	EAR99
AD8541	1	65	No	11	0.92	0.06	6000	38		2.5	5	5-lead SC70, 8-lead SOIC, 5-lead SOT-23	EAR99
AD8542	2	65	No	11	0.92	0.06	6000	38		2.5	5	8-lead SOIC, 8-lead MSOP, 8-lead TSSOP	EAR99
AD8544	4	65	No	11	0.92	0.06	6000	38		2.5	5	14-lead SOIC, 14-lead TSSOP	EAR99
LTC6256	2	65	Yes	71.5	1.8	50	350	21	2.5	1.8	5.25	8-lead SOT-23, 8-lead MSOP, 10-lead MSOP, 8-lead DFN	EAR99
LTC6257	4	65	Yes	71.5	1.8	50	350	21	2.5	1.8	5.25	16-lead MSOP	EAR99
LT6020	2	90	No	4.4	5	1	30	50	1.1	3	30	8-lead MSOP, 8-lead DFN, 10-lead DFN	EAR99
LT6020-1	2	90	Yes	4.4	5	1	30	50	1.1	3	30	8-lead MSOP, 8-lead DFN, 10-lead DFN	EAR99
LT1991	1	100	No	6.16	0.12	5	50	46	0.35	2.4	40	10-lead MSOP, 10-lead DFN	EAR99
LT1996	1	100	No	6.16	0.12	5	50	18	0.35	2.7	36	10-lead MSOP, 10-lead DFN	EAR99
LTC6084	2	110	Yes	16.5	0.5	0.04	750	31	3	2.5	5.5	8-lead MSOP, 10-lead DFN	EAR99
LTC6085	4	110	No	16.5	0.5	0.04	750	31	3	2.5	5.5	16-lead SSOP, 16-lead DFN	EAR99
LT1635	1	130	No	1.925	0.045	4.5	1300	50	1	1.1	14	8-lead PDIP, 8-lead SOIC	EAR99
LT6010	1	135	Yes	3.63	0.09	0.11	35	14	0.4	2.7	40	8-lead SOIC, 8-lead DFN	EAR99
LT6011	2	135	No	3.63	0.09	0.3	60	14	0.4	2.4	40	8-lead SOIC, 8-lead MSOP, 8-lead DFN	EAR99
LT6012	4	135	No	3.63	0.09	0.3	60	14	0.4	2.4	40	14-lead SOIC, 16-lead SSOP	EAR99
LTC2055	2	130	No	5.5	0.5	0.15	3		1.6	2.7	6	8-lead MSOP, 8-lead DFN	EAR99
LTC2055HV	2	150	No	5.5	0.5	0.15	3		1.6	2.7	11	8-lead MSOP, 8-lead DFN	EAR99
LT1464	2	145	No	11	0.9	0.002	800	24	2	10	40	8-lead PDIP, 8-lead SOIC	EAR99
LT1465	4	145	No	11	0.9	0.002	800	24	2	10	40	14-lead PDIP, 14-lead SOIC	EAR99
LT6013	1	145	No	17.6	0.2	0.25	35	9.5	0.2	2.7	40	8-lead SOIC, 8-lead DFN	EAR99
LT6014	2	145	No	17.6	0.2	0.4	60	9.5	0.2	2.7	40	8-lead SOIC, 8-lead DFN	EAR99
LTC2054	1	140	No	5.5	0.5	0.15	3		1.6	2.7	6	5-lead SOT-23	EAR99
LTC2054HV	1	175	No	5.5	0.5	0.15	3		1.6	2.7	11	5-lead SOT-23	EAR99
ADA4062-2	2	165	No	15.4	3.3	0.05	1500	36	1.5	8	36	10-lead LFCSP, 8-lead SOIC, 8-lead MSOP	EAR99
ADA4062-4	4	165	No	15.4	3.3	0.05	1500	36	1.5	8	36	16-lead LFCSP, 14-lead TSSOP	EAR99
ADA4091-2	2	165	No	13.97	0.46	80	250	24	0.8	2.7	36	8-lead LFCSP, 8-lead SOIC	EAR99
ADA4091-4	4	165	No	13.97	0.46	80	250	24	0.8	2.7	36	16-lead LFCSP, 14-lead TSSOP	EAR99
ADA4092-4	4	165	No	15.4	0.4	80	1500	24	0.8	2.7	36	14-lead TSSOP	EAR99
ADA4691-2	2	165	Yes	39.6	1.3	0.005	2500	13	3.2	2.7	5.5	9-ball WLCSOP, 10-lead LFCSP	EAR99
ADA4691-4	4	165	Yes	39.6	1.3	0.005	2500	13	3.2	2.7	5.5	16-lead LFCSP	EAR99
AD648	2	170	No	11	1.8	0.01	1000	30		9	36	8-lead PDIP, 8-lead SOIC	EAR99
LT1638	2	170	No	13.2	0.38	50	600	20	1	2.5	44	8-lead PDIP, 8-lead SOIC, 8-lead MSOP, 8-lead DFN	EAR99
LT1639	4	170	No	11.825	0.38	50	600	20	1	2.5	44	14-lead PDIP, 14-lead SOIC	EAR99
AD8244	4	180	No		0.8	0.003	350	13	0.4	3	36	10-lead MSOP	EAR99
AD8538	1	180	No	4.73	0.4	0.025	13	50	2	2.7	5	8-lead SOIC, 5-lead TSOT	EAR99
ADA4692-2	2	180	No	39.6	1.3	0.005	2500	16		2.7	5	8-lead LFCSP, 8-lead SOIC	EAR99
LT1637	1	190	Yes	11	0.35	50	350	27	0.6	2.7	44	8-lead PDIP, 8-lead SOIC, 8-lead MSOP, 8-lead DFN	EAR99
LTC1049	1	200	Yes	8.8	0.8	0.05	10	80	3	4.75	18	8-lead PDIP, 8-lead SOIC	EAR99
AD8539	2	210	No	4.73	0.4	0.06	15	52	1.2	2.7	5	8-lead SOIC, 8-lead MSOP	EAR99
AD8682	2	210	No	38.5	9	0.02	1000	36	1.3	9	36	8-lead SOIC, 8-lead MSOP	EAR99
AD8684	4	210	No	38.5	9	0.02	1000	36	1.3	9	36	14-lead SOIC, 14-lead TSSOP	EAR99
LT1783	1	210	Yes	13.75	0.42	80	800	20	0.6	2.2	18	5-lead SOT-23, 6-lead SOT-23	EAR99
AD8622	2	215	No	6.16	0.48	0.2	125	11	0.2	5	36	8-lead SOIC, 8-lead MSOP	EAR99
AD8624	4	215	No	6.16	0.48	0.2	125	11	0.2	5	36	16-lead LFCSP, 14-lead TSSOP	EAR99
ADA4692-4	4	225	No	39.6	1.3	0.005	2500	13		2.7	5.5	14-lead TSSOP	EAR99
LTC6261	1	245	Yes	330	7	100	400	13	1.25	1.8	5.25	6-lead SOT-23, 6-lead DFN	EAR99
LTC6262	2	245	Yes	330	7	100	400	13	1.25	1.8	5.25	8-lead SOT-23, 8-lead MSOP, 10-lead MSOP, 8-lead DFN	EAR99
LTC6263	4	245	Yes	330	7	750	400	13	1.25	1.8	5.25	16-lead MSOP	EAR99

Operational Amplifiers (Op Amps)

Low Power ($I_O/\text{Amp} < 0.5 \text{ mA}$) Amplifiers (Continued)

Part Number	Number of Amps	I_O/Amp (typ) (μA)	Shut-down	GBP (typ) (MHz)	Slew Rate (typ) ($\text{V}/\mu\text{s}$)	I_{BIAS} (max) (nA)	V_{OS} (max) (μV)	V_{NOISE} Density (typ) ($\text{nV}/\sqrt{\text{Hz}}$)	0.1 Hz to 10 Hz V_{NOISE} (typ) (μV p-p)	V_s Span (min) (V)	V_s Span (max) (V)	Package	ECCN Code
LT1351	1	250	Yes	33	200	50	600	14		5	36	8-lead PDIP, 8-lead SOIC, 8-lead MSOP	EAR99
LT1352	2	250	No	33	200	50	600	14		5	36	8-lead PDIP, 8-lead SOIC	EAR99
LT1353	4	250	No	33	200	50	600	14		5	36	14-lead SOIC	EAR99
AD8663	1	285	No	5.94	0.3	0.045	300	21	2.5	5	16	8-lead LFCSP, 8-lead SOIC	EAR99
AD8667	2	285	No	5.94	0.3	0.045	300	21	2.5	5	16	8-lead SOIC, 8-lead MSOP	EAR99
AD8669	4	285	No	5.94	0.3	0.045	300	21	2.5	5	16	14-lead SOIC, 14-lead TSSOP	EAR99
AD8641	1	290	No	38.5	3	0.001	750	27.5	4.2	5	26	5-lead SC70, 8-lead SOIC	EAR99
AD8642	2	290	No	38.5	3	0.001	750	27.5	4.2	5	26	8-lead SOIC, 8-lead MSOP	EAR99
AD8643	4	290	No	38.5	3	0.001	750	27.5	4.2	5	26	16-lead LFCSP, 14-lead SOIC	EAR99
LT6015	1	315	No	35.2	0.75	5	50	18	0.5	3	50	5-lead SOT-23	EAR99
LT6016	2	315	No	35.2	0.75	5	50	18	0.5	3	50	8-lead MSOP	EAR99
LT6017	4	315	No	35.2	0.75	5	50	18	0.5	3	50	22-lead DFN	EAR99
LT1413	2	330	No	10.45	0.3		150	23	0.55	3	22	8-lead PDIP, 8-lead SOIC	EAR99
LTC6081	2	330	Yes	39.6	1	0.001	70	13	1.3	2.7	5.5	8-lead MSOP, 10-lead DFN	EAR99
LTC6082	4	330	No	39.6	1	0.001	70	13	1.3	2.7	5.5	16-lead SSOP, 16-lead DFN	EAR99
LT1006	1	340	No	6.6	0.4	15	50	22	0.55	4	44	8-lead PDIP, 8-lead SOIC	EAR99
LT1366	2	340	No	4.4	0.13	35	475	29		2	36	8-lead PDIP, 8-lead SOIC	EAR99
LT1367	4	340	No	4.4	0.13	35	800	29		2	36	14-lead SOIC	EAR99
LT1368	2	340	No	1.76	0.065	35	475	29		2	36	8-lead PDIP, 8-lead SOIC	EAR99
LT1369	4	340	No	1.76	0.065	35	800	29		2	36	14-lead SOIC	EAR99
LT1013	2	350	No	8.8	0.4	20	150	22	0.55	4	44	8-lead TO-5 (0.200 in PCD), 8-lead PDIP, 8-lead SOIC	EAR99
LT1013AMH	2	350	No	8.8	0.4	20	150	22	0.55	4	44	8-lead TO-5 (0.200 in PCD), 8-lead PDIP, 8-lead SOIC	EAR99
LT1014	4	350	No	8.8	0.4	20	150	22	0.55	4	44	14-lead PDIP, 16-lead SOIC	EAR99
LT1097	1	350	No	7.7	0.2	0.25	50	14	0.5	2	40	8-lead PDIP, 8-lead SOIC	EAR99
LT1112	2	350	No	8.25	0.3	0.25	60	14	0.3	2	40	8-lead PDIP, 8-lead SOIC	EAR99
LT1114	4	350	No	8.25	0.3	0.25	60	14	0.3	2	40	14-lead PDIP, 16-lead SOIC	EAR99
LT1997-3	1	350	Yes	12.1	0.75	5	60	50	1.4	3.3	50	16-lead MSOP (4 pins removed), 14-lead DFN	EAR99
LT1012	1	370	No	11	0.2	0.1	25	14	0.5	2.4	40	8-lead PDIP, 8-lead SOIC	EAR99
LT1218	1	370	Yes	3.3	0.1	70	90	33		2	36	8-lead PDIP, 8-lead SOIC	EAR99
LT1218L	1	370		3.3	0.1	70	90	33		2	16	8-lead PDIP, 8-lead SOIC	EAR99
LT1219	1	370	Yes	1.65	0.05	70	90	33		2	36	8-lead PDIP, 8-lead SOIC	EAR99
LT1219L	1	370		1.65	0.05	70	90	33		2	16	8-lead PDIP, 8-lead SOIC	EAR99
LT1008	1	380	No	11	0.2	0.1	120	14	0.5	4	40	8-lead PDIP, 8-lead SOIC	EAR99
LT1024	2	380	No	11	0.2	0.12	50	14	0.5	4	40	14-lead PDIP	EAR99
AD8005	1	400	No	2970	1500	10,000	30,000	4		8	12	8-lead SOIC, 5-lead SOT-23	EAR99
ADA4077-1	1	400	No	42.9	1	1	35	7	0.25	5	30	8-lead SOIC, 8-lead MSOP	EAR99
ADA4077-2	2	400	No	42.9	1	1	35	7	0.25	5	30	8-lead SOIC, 8-lead MSOP	EAR99
ADA4077-4	4	400	No	42.9	1	1	50	7	0.25	5	30	14-lead SOIC, 14-lead TSSOP	EAR99
ADA4665-2	2	400	No	13.2	1	0.001	4000	27	3	5	16	8-lead SOIC, 8-lead MSOP	EAR99
LT1492	2	425	No	49.5	1.8	100	180	16.5	0.33	2.1	36	8-lead PDIP, 8-lead SOIC	EAR99
LT1493	4	425	No	49.5	1.8	100	130	16.5	0.33	2.1	36	16-lead SOIC	EAR99
AD8508	4	500	No	1.045	0.013	0.01	2500	45	2.8	1.8	5	14-ball WLCSOP, 14-lead TSSOP	EAR99
AD8515	1	500	No	55	2.7	0.03	6000	20		1.8	5	5-lead SC70, 5-lead SOT-23	EAR99
ADA4177-1	1	500	No	38.5	1.5	1	60	8	0.175	10	30	8-lead SOIC, 8-lead MSOP	EAR99
ADA4177-2	2	500	No	38.5	1.5	1	60	8	0.175	10	30	8-lead SOIC, 8-lead MSOP	EAR99
ADA4177-4	4	500	No	38.5	1.5	1	60	8	0.175	10	30	14-lead SOIC, 14-lead TSSOP	EAR99
LT1784	1	500	Yes	27.5	2.1	500	3500	25	1.5	2	18	5-lead SOT-23, 6-lead SOT-23	EAR99

Operational Amplifiers (Op Amps)

ADA4530-1: Femtoampere Input Bias Current Electrometer Amplifier

Key Features

- ▶ Low input bias current
- ▶ ± 20 fA maximum at $T_A = 25^\circ\text{C}$ (guaranteed at production test)
- ▶ ± 20 fA maximum at $-40^\circ\text{C} < T_A < +85^\circ\text{C}$
- ▶ ± 250 fA maximum at $-40^\circ\text{C} < T_A < +125^\circ\text{C}$ (guaranteed at production test)
- ▶ Low offset voltage: 50 μV maximum over specified CMRR range
- ▶ Offset voltage drift: ± 0.13 $\mu\text{V}/^\circ\text{C}$ typical, ± 0.5 $\mu\text{V}/^\circ\text{C}$ maximum
- ▶ Integrated guard buffer with 100 μV maximum offset
- ▶ Low voltage noise density: 14 $\text{nV}/\sqrt{\text{Hz}}$ at 10 kHz
- ▶ Wide bandwidth: 2 MHz unity-gain crossover
- ▶ Supply voltage: 4.5 V to 16 V (± 2.25 V to ± 8 V)
- ▶ Operating temperature: -40°C to $+125^\circ\text{C}$
- ▶ Long-term offset voltage drift (10,000 hours): 0.5 μV typical
- ▶ Temperature hysteresis: 1.5 μV typical

Benefits

- ▶ Easy to use
- ▶ Integrated guard ring driver
- ▶ Surface-mount package
- ▶ Pinout optimized for input pin isolation from power supplies
- ▶ Allows chemical analysis instrument designers to design high performance portable systems
- ▶ Enables customers to bring the lab to the field and make adjustments immediately vs. having to bring the sample all the way back to the lab

Applications

- ▶ Laboratory and analytical instrumentation: spectrophotometers, chromatographs, mass spectrometers, and potentiostatic and amperostatic coulometry
- ▶ Instrumentation: picoammeters and coulombmeters
- ▶ Transimpedance amplifier (TIA) for photodiodes, ion chambers, and working electrode measurements
- ▶ High impedance buffering for chemical sensors and capacitive sensors

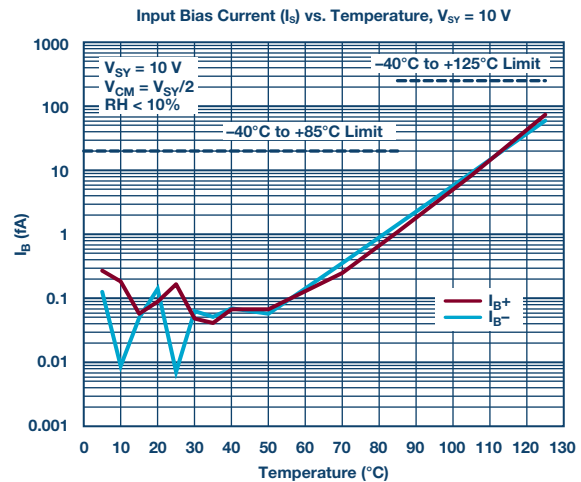

Low Input Bias Current ($I_{BIAS} < 75$ pA) Amplifiers

Part Number	Number of Amps	I_{BIAS} (max) (pA)	V_{OS} (max) (μV)	V_{OS} TC (max) ($\mu\text{V}/^\circ\text{C}$)	V_{NOISE} Density (typ) ($\text{nV}/\sqrt{\text{Hz}}$)	0.1 Hz to 10 Hz V_{NOISE} (typ) (μV p-p)	GBP (typ) (MHz)	Slew Rate (typ) (V/ μs)	I_O /Amp (typ) (mA)	V_S Span (min) (V)	V_S Span (max) (V)	Package	ECCN Code
LTC2064 <i>New</i>	2	20	5	0.02	220	4.6	0.02	0.004	0.001	1.7	5.25	8-lead MSOP, 10-lead DFN	EAR99
LTC2066 <i>New</i>	1	35	5	0.02	80	1.7	0.1	0.018	0.008	1.7	5.25	5-lead SOT-23, 6-lead SC70	EAR99
LTC2067 <i>New</i>	2	35	5	0.02	80	1.7	0.1	0.018	0.008	1.7	5.25	8-lead MSOP, 10-lead DFN	EAR99
ADA4625-1 <i>New</i>	1	75	80	2.1	3.3	0.15	18	48	4	5	36	8-lead SOIC-EP	EAR99
LTC2058 <i>New</i>	2	100	5	0.025	9	0.2	2.5	1.6	0.95	4.75	36	12-lead MSOP-EP, 8-lead SOIC-EP	EAR99
ADA4530-1	1	0.02	40	0.5	14	4	2	1.4	0.9	4.5	16	8-lead SOIC	EAR99
LTC6268	1	0.02	700		4.3	13	500	400	16.5	3.1	5.25		EAR99
LTC6268-10	1	0.02	700		4	12.6	4000	1500	16.5	3.1	5.25	8-lead SOIC, 6-lead SOT-23	EAR99
LTC6269	2	0.02	700		4.3	13	500	400	16.5	3.1	5.25	8-lead MSOP-EP, 10-lead DFN	EAR99
LTC6269-10	2	0.02	700		4	12.6	4000	1500	16.5	3.1	5.25	8-lead MSOP-EP, 10-lead DFN	EAR99
AD549	1	0.06	500	15	35	4	1	3	0.7	10	36	8-lead header	EAR99
AD8603	1	1	300	4.5	22	2.3	0.316	0.1	0.05	1.8	5	5-lead TSOT	EAR99
AD8605	1	1	300	4.5	6.5	2.3	10	5	1.2	2.7	5	5-ball WLCSP, 5-lead SOT-23	EAR99
AD8606	2	1	300	4.5	6.5	2.3	10	5	1.2	2.7	5	8-ball WLCSP, 8-lead SOIC, 8-lead MSOP	EAR99
AD8607	2	1	300	4.5	22	2.3	0.316	0.1	0.05	1.8	5	8-lead SOIC, 8-lead MSOP	EAR99

Operational Amplifiers (Op Amps)

Low Input Bias Current ($I_{BIAS} < 75 \text{ pA}$) Amplifiers (Continued)

Part Number	Number of Amps	I_{BIAS} (max) (pA)	V_{OS} (max) (μV)	V_{OS} TC (max) ($\mu\text{V}/^\circ\text{C}$)	V_{NOISE} Density (typ) (nV/ $\sqrt{\text{Hz}}$)	0.1 Hz to 10 Hz V_{NOISE} (typ) ($\mu\text{V p-p}$)	GBP (typ) (MHz)	Slew Rate (typ) (V/ μs)	I_O /Amp (typ) (mA)	V_s Span (min) (V)	V_s Span (max) (V)	Package	ECCN Code
AD8608	4	1	300	6	6.5	2.3	10	5	1.2	2.7	5	Chips or die, 14-lead SOIC, 14-lead TSSOP	EAR99
AD8609	4	1	300	4.5	22	2.3	0.316	0.1	0.04	1.8	5	14-lead SOIC, 14-lead TSSOP	EAR99
AD8613	1	1	2200	7	22	2.3	0.35	0.1	0.038	1.8	5	5-lead SC70, 5-lead TSOT	EAR99
AD8615	1	1	100	10	7	2.4	24	12	1.7	2.7	5.5	5-lead TSOT	EAR99
AD8616	2	1	60	7	7	2.4	24	12	1.7	2.7	5.5	8-lead SOIC, 8-lead MSOP	EAR99
AD8617	2	1	2200	4.5	22	2.3	0.4	0.1	0.038	1.8	5	8-lead LFCSP, 8-lead SOIC, 8-lead MSOP	EAR99
AD8618	4	1	60	7	7	2.4	24	12	2	2.7	5.5	14-lead SOIC, 14-lead TSSOP	EAR99
AD8619	4	1	2200	4.5	22	2.3	0.4	0.1	0.038	1.8	5	14-lead SOIC, 14-lead TSSOP	EAR99
AD8625	4	1	750		16	2.5	5	5	0.85	5	26	14-lead SOIC, 14-lead TSSOP	EAR99
AD8626	2	1	750		16	2.5	5	5	0.85	5	26	8-lead SOIC, 8-lead MSOP	EAR99
AD8627	1	1	750		16	2.5	5	5	0.85	5	26	5-lead SC70, 8-lead SOIC	EAR99
AD8641	1	1	750		27.5	4.2	3.5	3	0.29	5	26	5-lead SC70, 8-lead SOIC	EAR99
AD8642	2	1	750		27.5	4.2	3.5	3	0.29	5	26	8-lead SOIC, 8-lead MSOP	EAR99
AD8643	4	1	750		27.5	4.2	3.5	3	0.29	5	26	16-lead LFCSP, 14-lead SOIC	EAR99
AD8646	2	1	2500	7.5	6	2.3	24	11	2	2.7	5.5	8-lead SOIC, 8-lead MSOP	EAR99
AD8647	2	1	2500	7.5	6	2.3	24	11	2	2.7	5.5	10-lead MSOP	EAR99
AD8648	4	1	2500	7.5	6	2.3	24	11	2	2.7	5.5	14-lead SOIC, 14-lead TSSOP	EAR99
AD8661	1	1	160	10	10	2.5	4	3.5	1.4	5	16	8-lead LFCSP, 8-lead SOIC	EAR99
AD8662	2	1	160	9	10	2.5	4	3.5	1.4	5	16	8-lead SOIC, 8-lead MSOP	EAR99
AD8664	4	1	160	9	10	2.5	4	3.5	1.55	5	16	14-lead SOIC, 14-lead TSSOP	EAR99
AD8665	1	1	2500	10	8	2.5	4	3.5	1.55	5	16	8-lead SOIC, 5-lead SOT-23	EAR99
AD8666	2	1	2500	10	8	2.5	4	3.5	1.55	5	16	8-lead SOIC, 8-lead MSOP	EAR99
AD8668	4	1	2500	10	8	2.5	4	3.5	1.55	5	16	14-lead SOIC, 14-lead TSSOP	EAR99
AD8691	1	1	2000	12	6.5	1.6	10	5	1.05	2.7	5.5	5-lead SC70, 5-lead TSOT	EAR99
AD8692	2	1	2000	6	6.5	1.6	10	5	1.05	2.7	5.5	8-lead SOIC, 8-lead MSOP	EAR99
AD8694	4	1	2000	6	6.5	1.6	10	5	1.05	2.7	5.5	14-lead SOIC, 14-lead TSSOP	EAR99
ADA4350	1	1	80	1.6	5		175	100	8.5	3.3	12	28-lead TSSOP	EAR99
ADA4665-2	2	1	4000		27	3	1.2	1	0.4	5	16	8-lead SOIC, 8-lead MSOP	EAR99
LTC6078	2	1	25	0.7	18	1	0.75	0.05	0.054	2.7	5.5	8-lead MSOP, 10-lead DFN	EAR99
LTC6079	4	1	25	1.4	18	1	0.75	0.05	0.054	2.7	5.5	16-lead SSOP, 16-lead DFN	EAR99
LTC6081	2	1	70	0.8	13	1.3	3.6	1	0.33	2.7	5.5	8-lead MSOP, 10-lead DFN	EAR99
LTC6082	4	1	70	0.8	13	1.3	3.6	1	0.33	2.7	5.5	16-lead SSOP, 16-lead DFN	EAR99
LTC6240	1	1	175	2.5	7	0.55	18	10	2	2.8	6	8-lead SOIC, 5-lead SOT-23	EAR99
LTC6240HV	1	1	175	2.5	7	0.55	18	10	2	2.8	12	8-lead SOIC, 5-lead SOT-23	EAR99
AD795	1	2	500	10	9	1	1.6	1	1.5	8	36	8-lead SOIC	EAR99
ADA4500-2	2	2	120	5.5	14.5	2	10	5.5	1.55	2.7	5.5	8-lead LFCSP, 8-lead MSOP	EAR99
ADA4505-1	1	2	3000		65	2.95	0.05	0.006	0.009	1.8	5	6-ball WLCSF, 5-lead SOT-23	EAR99
ADA4505-2	2	2	3000		65	2.95	0.05	0.006	0.009	1.8	5	8-ball WLCSF, 8-lead MSOP	EAR99
ADA4505-4	4	2	3000		65	2.95	0.05	0.006	0.009	1.8	5	14-ball WLCSF, 14-lead TSSOP	EAR99
LT1462	2	2	800	20	76	2	0.175	0.13	0.028	10	40	8-lead PDIP, 8-lead SOIC	EAR99
LT1463	4	2	800	20	76	2	0.175	0.13	0.028	10	40	14-lead PDIP, 14-lead SOIC	EAR99
LT1464	2	2	800	20	24	2	1	0.9	0.145	10	40	8-lead PDIP, 8-lead SOIC	EAR99
LT1465	4	2	800	20	24	2	1	0.9	0.145	10	40	14-lead PDIP, 14-lead SOIC	EAR99
AD8244	4	3	350	3	13	0.4		0.8	0.18	3	36	10-lead MSOP	EAR99
AD8067	1	5	1000	15	6.6		200	640	7	5	24	5-lead SOT-23	EAR99
ADA4627-1	1	5	200	2	4.8	0.7	19	56	7	9	36	8-lead LFCSP, 8-lead SOIC	EAR99
ADA4637-1	1	5	200	2	4.8	0.7	79.9	170	7	9	30	8-lead LFCSP, 8-lead SOIC	EAR99
ADA4691-2	2	5	2500	4	13	3.2	3.6	1.3	0.165	2.7	5.5	9-ball WLCSF, 10-lead LFCSP	EAR99
ADA4691-4	4	5	2500	4	13	3.2	3.6	1.3	0.165	2.7	5.5	16-lead LFCSP	EAR99
ADA4692-2	2	5	2500	4	16		3.6	1.3	0.18	2.7	5	8-lead LFCSP, 8-lead SOIC	EAR99
ADA4692-4	4	5	2500	4	13		3.6	1.3	0.225	2.7	5.5	14-lead TSSOP	EAR99
AD8065	1	7	1500	17	7		145	180	7.4	5	24	Chips or die, 8-lead SOIC, 5-lead SOT-23	EAR99
AD8066	2	7	1500	17	7		145	180	7.4	5	24	8-lead SOIC, 8-lead MSOP	EAR99
AD648	2	10	1000	10	30		1	1.8	0.17	9	36	8-lead PDIP, 8-lead SOIC	EAR99

Operational Amplifiers (Op Amps)

Low Input Bias Current ($I_{BIAS} < 75 \text{ pA}$) Amplifiers (Continued)

Part Number	Number of Amps	I_{BIAS} (max) (pA)	V_{OS} (max) (μV)	V_{OS} TC (max) ($\mu\text{V}/^\circ\text{C}$)	V_{NOISE} Density (typ) (nV/ $\sqrt{\text{Hz}}$)	0.1 Hz to 10 Hz V_{NOISE} (typ) ($\mu\text{V p-p}$)	GBP (typ) (MHz)	Slew Rate (typ) (V/ μs)	I_O /Amp (typ) (mA)	V_S Span (min) (V)	V_S Span (max) (V)	Package	ECCN Code
AD820	1	10	1000		13	2	1.8	3	0.9	5	30	8-lead PDIP, 8-lead SOIC, 8-lead MSOP	EAR99
AD8500	1	10	1000	10	190		0.007	0.004	0.001	1.8	5	5-lead SC70	EAR99
AD8502	2	10	3000		190	6	0.007	0.004	0.001	1.8	5	8-lead SOT-23	EAR99
AD8504	4	10	3000		190	6	0.007	0.004	0.001	1.8	5	14-lead TSSOP	EAR99
AD8505	1	10	2500		45	2.8	0.095	0.013	0.017	1.8	5	6-ball WLCSP, 5-lead SOT-23	EAR99
AD8506	2	10	2500		45	2.8	0.095	0.013	0.02	1.8	5	8-ball WLCSP, 8-lead MSOP	EAR99
AD8508	4	10	2500		45	2.8	0.095	0.013	0.5	1.8	5	14-ball WLCSP, 14-lead TSSOP	EAR99
AD8610	1	10	100	1	6	1.8	25	60	3.5	10	26	8-lead SOIC, 8-lead MSOP	EAR99
AD8620	2	10	150	1.5	6	1.8	25	60	3.5	10	26	8-lead SOIC	EAR99
AD8651	1	10	350		4.5		50	41	9	2.7	5.5	8-lead SOIC, 8-lead MSOP	EAR99
AD8652	2	10	300		4.5		50	41	9	2.7	5.5	8-lead SOIC, 8-lead MSOP	EAR99
AD8655	1	10	250	2.3	2.7		28	11	4.5	2.7	5.5	8-lead SOIC, 8-lead MSOP	EAR99
AD8656	2	10	250	2.3	2.7		28	11	4.5	2.7	5.5	8-lead SOIC, 8-lead MSOP	EAR99
ADA4622-1	1	10	350	5	12.5	0.75	8	23	0.715	5	30	8-lead SOIC, 5-lead SOT-23	EAR99
ADA4622-2	2	10	350	5	12.5	0.75	8	23	0.665	5	30	8-lead LFCSP, 8-lead SOIC, 8-lead MSOP	EAR99
ADA4622-4	4	10	350	5	12.5	0.75	8	23	0.665	5	30	16-lead LFCSP, 14-lead SOIC	EAR99
LT1793	1	10	800	13	6	2.4	4.2	3.4	4.2	10	40	8-lead PDIP, 8-lead SOIC	EAR99
AD8033	1	12	2000	24	11		45	80	3.3	5	24	5-lead SC70, 8-lead SOIC	EAR99
AD8034	2	12	2000	24	11		45	80	3.3	5	24	8-lead SOIC, 8-lead SOT-23, chips or die	EAR99
AD822	2	12	1500		13	2	1.8	3	0.9	5	30	Chips or die, 8-lead PDIP, 8-lead SOIC, 8-lead MSOP	EAR99
ADA4661-2	2	15	150	3.1	18	3	4	2.2	0.63	3	18	8-lead LFCSP, 8-lead MSOP	EAR99
ADA4666-2	2	15	2200	3.1	18	3	4	2	0.63	3	18	8-lead LFCSP, 8-lead MSOP	EAR99
AD8657	2	20	350		45	5	0.23	0.08	0.022	2.7	18	8-lead LFCSP, 8-lead MSOP	EAR99
AD8659	4	20	350		45	5	0.23	0.08	0.022	2.7	18	16-lead LFCSP, 14-lead SOIC	EAR99
AD8682	2	20	1000		36	1.3	3.5	9	0.21	9	36	8-lead SOIC, 8-lead MSOP	EAR99
AD8684	4	20	1000		36	1.3	3.5	9	0.21	9	36	14-lead SOIC, 14-lead TSSOP	EAR99
ADA4817-1	1	20	2000		4		410	870	19	5	10	8-lead LFCSP, 8-lead SOIC-EP	EAR99
ADA4817-2	2	20	2000		4		410	870	19	5	10	16-lead LFCSP	EAR99
LT1169	2	20	2000	50	6	2.4	5.3	4.2	5.3	9	40	8-lead PDIP, 8-lead SOIC	EAR99
LTC2063	1	20	5	0.02	220	4.6	0.02	0.004	0.001	1.7	5.25	5-lead SOT-23, 6-lead SC70	EAR99
AD823A	2	25	3500		13		10	35	5.1	3	36	8-lead SOIC, 8-lead MSOP	EAR99
AD8538	1	25	13	0.1	50	2	0.43	0.4	0.18	2.7	5	8-lead SOIC, 5-lead TSOT	EAR99
ADA4610-1	1	25	400	4	7.3	0.45	16.3	25	1.6	10	36	8-lead SOIC, 5-lead SOT-23	EAR99
ADA4610-2	2	25	400	4	7.3	0.45	16.3	25	1.6	10	36	8-lead LFCSP, 8-lead SOIC, 8-lead MSOP	EAR99
ADA4610-4	4	25	400	8	7.3	0.45	16.3	25	1.6	10	36	16-lead LFCSP, 14-lead SOIC	EAR99
AD823	2	30	3500		16		10	25	5.2	3	36	8-lead PDIP, 8-lead SOIC	EAR99
AD8515	1	30	6000		20		5	2.7	0.5	1.8	5	5-lead SC70, 5-lead SOT-23	EAR99
ADA4001-2	2	30	1500		7.7		16.7	25	2	9	36	8-lead SOIC	EAR99
LTC1047	2	30	10	0.05		3.5	0.2	0.2	0.06	4.75	16	8-lead PDIP, 16-lead SOIC	EAR99
LTC1050	1	30	5	0.05	90	1.6	2.5	4	1	4.75	18	14-lead PDIP, 8-lead PDIP, 8-lead SOIC	EAR99
LTC1052	1	30	5	0.05	30	1.5	1.2	4	1.7	4.75	18	14-lead PDIP, 8-lead PDIP, 16-lead SOIC	EAR99
AD824	4	35	2500		16	2	2	2	0.56	2.7	30	14-lead SOIC	EAR99
AD825	1	40	2000		12		26	140	6.5	10	36	8-lead SOIC, 16-lead SOIC—wide, chips or die	EAR99
ADA4000-1	1	40	1700		16	1	5	20	1.65	8	36	8-lead SOIC, 5-lead TSOT	EAR99
ADA4000-2	2	40	1700		16	1	5	20	1.65	8	36	8-lead SOIC, 8-lead MSOP	EAR99
ADA4000-4	4	40	1700		16	1	5	20	1.65	8	36	14-lead SOIC, 14-lead TSSOP	EAR99
LTC6084	2	40	750	5	31	3	1.5	0.5	0.11	2.5	5.5	8-lead MSOP, 10-lead DFN	EAR99
LTC6085	4	40	750	5	31	3	1.5	0.5	0.11	2.5	5.5	16-lead SSOP, 16-lead DFN	EAR99
LTC6087	2	40	750	5	12	5.8	14	7.2	1.05	2.7	5.5	8-lead MSOP, 10-lead DFN	EAR99
LTC6088	4	40	750	5	12	5.8	14	7.2	1.05	2.7	5.5	16-lead SSOP, 16-lead DFN	EAR99
AD8663	1	45	300	5	21	2.5	0.54	0.3	0.285	5	16	8-lead LFCSP, 8-lead SOIC	EAR99
AD8667	2	45	300	5	21	2.5	0.54	0.3	0.285	5	16	8-lead SOIC, 8-lead MSOP	EAR99

Operational Amplifiers (Op Amps)

Low Input Bias Current ($I_{BIAS} < 75 \text{ pA}$) Amplifiers (Continued)

Part Number	Number of Amps	I_{BIAS} (max) (pA)	V_{OS} (max) (μV)	V_{OS} TC (max) ($\mu\text{V}/^\circ\text{C}$)	V_{NOISE} Density (typ) (nV/ $\sqrt{\text{Hz}}$)	0.1 Hz to 10 Hz V_{NOISE} (typ) (μV p-p)	GBP (typ) (MHz)	Slew Rate (typ) (V/ μs)	I_O /Amp (typ) (mA)	V_s Span (min) (V)	V_s Span (max) (V)	Package	ECCN Code
AD8669	4	45	300	5	21	2.5	0.54	0.3	0.285	5	16	14-lead SOIC, 14-lead TSSOP	EAR99
AD711	1	50	1000	20	16	2	4	20	2.8	9	36	8-lead PDIP, 8-lead CerDIP, 8-lead SOIC	EAR99
AD8531	1	50	25,000		30		3	5	1.25	3	6	5-lead SC70, 8-lead SOIC, 5-lead SOT-23	EAR99
AD8532	2	50	25,000		30		3	5	1.25	3	6	8-lead SOIC, 8-lead MSOP, 8-lead TSSOP	EAR99
AD8534	4	50	25,000		30		3	5	1.25	3	6	14-lead SOIC, 14-lead TSSOP	EAR99
AD8551	1	50	5	0.04	42	1	1.5	0.4	0.975	2.7	5	8-lead SOIC, 8-lead MSOP	EAR99
AD8552	2	50	5	0.04	42	1	1.5	0.4	0.975	2.7	5	8-lead SOIC, 8-lead TSSOP	EAR99
AD8554	4	50	5	0.04	42	1	1.5	0.4	0.975	2.7	5	14-lead SOIC, 14-lead TSSOP	EAR99
AD8571	1	50	5	0.04	51	1.3	1.5	0.4	0.975	2.7	5.5	8-lead SOIC, 8-lead MSOP	EAR99
AD8572	2	50	5	0.04	51	1.3	1.5	0.4	0.975	2.7	5.5	8-lead SOIC, 8-lead TSSOP	EAR99
AD8574	4	50	5	0.04	51	1.3	1.5	0.4	0.975	2.7	5.5	14-lead SOIC, 14-lead TSSOP	EAR99
AD8591	1	50	25,000		30		3	5	1.25	2.5	6	6-lead SOT-23	EAR99
AD8592	2	50	25,000		30		3	5	1.25	2.5	6	10-lead MSOP	EAR99
ADA4062-2	2	50	1500		36	1.5	1.4	3.3	0.165	8	36	10-lead LFCSP, 8-lead SOIC, 8-lead MSOP	EAR99
ADA4062-4	4	50	1500		36	1.5	1.4	3.3	0.165	8	36	16-lead LFCSP, 14-lead TSSOP	EAR99
ADA4891-1	1	50	10,000		9		105	170	4.4	2.7	5.5	8-lead SOIC, 5-lead SOT-23	EAR99
ADA4891-2	2	50	10,000		9		105	170	4.4	2.7	5.5	8-lead SOIC, 8-lead MSOP	EAR99
ADA4891-3	3	50	10,000		9		105	170	4.4	2.7	5.5	14-lead SOIC, 14-lead TSSOP	EAR99
ADA4891-4	4	50	10,000		9		105	170	4.4	2.7	5.5	14-lead SOIC, 14-lead TSSOP	EAR99
LT1022	1	50	250	5	14	2.5	8.5	26	5.2	20	40	8-lead TO-5 (0.200 in PCD), 8-lead PDIP	EAR99
LT1055	1	50	700	12	15	2	4.5	12	2.8	8	40	8-lead PDIP, 8-lead SOIC	EAR99
LT1056	1	50	800	12	15	2.8	5.5	14	5	8	40	8-lead PDIP, 8-lead SOIC	EAR99
LT1057	2	50	450	10	13	2	5	14	1.6	8	40	8-lead PDIP, 8-lead SOIC	EAR99
LT1058	4	50	600	15	13	2.4	5	14	1.6	8	40	14-lead PDIP, 16-lead SOIC	EAR99
LTC1049	1	50	10	0.1	80	3	0.8	0.8	0.2	4.75	18	8-lead PDIP, 8-lead SOIC	EAR99
LTC6090	1	50	1000		14	3.5	12	24	2.7	9.5	140	16-lead TSSOP-EP, 8-lead SOIC-EP	EAR99
LTC6090-5	1	50	1000		14	3.5	24	37	2.7	9.5	140	16-lead TSSOP-EP, 8-lead SOIC-EP	EAR99
LTC6091	2	50	1000	5	14	3.5	12	21	2.8	9.5	140	16-lead QFN	EAR99
AD8539	2	60	15	0.1	52	1.2	0.43	0.4	0.21	2.7	5	8-lead SOIC, 8-lead MSOP	EAR99
AD8541	1	60	6000		38		1	0.92	0.065	2.5	5	5-lead SC70, 8-lead SOIC, 5-lead SOT-23	EAR99
AD8542	2	60	6000		38		1	0.92	0.065	2.5	5	8-lead SOIC, 8-lead MSOP, 8-lead TSSOP	EAR99
AD8544	4	60	6000		38		1	0.92	0.065	2.5	5	14-lead SOIC, 14-lead TSSOP	EAR99
AD8601	1	60	500		18		8.4	6	0.75	2.7	5	5-lead SOT-23	EAR99
AD8602	2	60	500		18		8.4	6	0.75	2.7	5.5	8-lead SOIC, 8-lead MSOP	EAR99
AD8604	4	60	600		18		8.4	6	0.75	2.7	5.5	14-lead SOIC, 16-lead QSOP, 14-lead TSSOP	EAR99
LTC1051	2	65	5	0.05	70	1.5	2.5	4	1	4.75	16.5	8-lead PDIP, 16-lead SOIC	EAR99
LTC1053	4	65	5	0.05	70	1.5	2.5	4	1	4.75	16.5	14-lead PDIP, 18-lead SOIC	EAR99
ADA4051-1	1	70	17	0.1	95	1.96	0.125	0.06	0.015	1.8	5.5	5-lead SC70, 5-lead SOT-23	EAR99
ADA4051-2	2	70	15	0.1	95	1.96	0.125	0.06	0.013	1.8	5.5	8-lead LFCSP, 8-lead MSOP	EAR99
AD712	2	75	1000	20	16	2	4	20	2.8	9	36	8-lead PDIP, 8-lead CerDIP, 8-lead SOIC	EAR99
AD8638	1	75	9	0.06	60	1.2	1.5	2	1.5	4.5	16	8-lead SOIC, 5-lead SOT-23	EAR99
AD8639	2	75	9	0.06	60	1.2	1.5	2	1.5	4.5	16	8-lead LFCSP, 8-lead SOIC, 8-lead MSOP	EAR99
LT1122	1	75	600	18	14	3	14	80	7.5	20	40	8-lead PDIP, 8-lead SOIC	EAR99
LTC2050	1	75	3	0.03		1.5	3	2	0.8	2.7	6	8-lead SOIC, 5-lead SOT-23, 6-lead SOT-23	EAR99
LTC2050HV	1	75	3	0.03		1.5	3	2	0.8	2.7	11	8-lead SOIC, 5-lead SOT-23, 6-lead SOT-23	EAR99
LTC2051	2	75	3	0.03		1.5	3	2	0.85	2.7	6	8-lead SOIC, 8-lead MSOP, 10-lead MSOP, 8-lead DFN	EAR99
LTC2051HV	2	75	3	0.03		1.5	3	2	0.85	2.7	11	8-lead SOIC, 8-lead MSOP, 10-lead MSOP, 8-lead DFN	EAR99

Operational Amplifiers (Op Amps)

Low Input Bias Current ($I_{BIAS} < 75 \text{ pA}$) Amplifiers (Continued)

Part Number	Number of Amps	I_{BIAS} (max) (pA)	V_{OS} (max) (μV)	V_{OS} TC (max) ($\mu\text{V}/^\circ\text{C}$)	V_{NOISE} Density (typ) (nV/ $\sqrt{\text{Hz}}$)	0.1 Hz to 10 Hz V_{NOISE} (typ) ($\mu\text{V p-p}$)	GBP (typ) (MHz)	Slew Rate (typ) (V/ μs)	I_O /Amp (typ) (mA)	V_S Span (min) (V)	V_S Span (max) (V)	Package	ECCN Code
LTC2052	4	75	3	0.03		1.5	3	2	0.85	2.7	6	14-lead SOIC, 16-lead SSOP	EAR99
LTC2052HV	4	75	3	0.03		1.5	3	2	0.85	2.7	11	14-lead SOIC, 16-lead SSOP	EAR99
LTC6241	2	75	125	2.5	7	1	18	10	1.8	2.8	6	8-lead SOIC, 8-lead DFN	EAR99
LTC6241HV	2	75	125	2.5	7	1	18	10	1.8	2.8	12	8-lead SOIC, 8-lead DFN	EAR99
LTC6242	4	75	125	2.5	7	1	18	10	1.8	2.8	6	16-lead SSOP, 16-lead DFN	EAR99
LTC6242HV	4	75	125	2.5	7	1	18	10	1.8	2.8	12	16-lead SSOP, 16-lead DFN	EAR99
LTC6244	2	75	100	2.5	8	1.5	50	35	6.25	2.8	6	8-lead MSOP, 8-lead DFN	EAR99
LTC6244HV	2	75	100	2.5	8	1.5	50	35	6.25	2.8	12	8-lead MSOP, 8-lead DFN	EAR99
ADA4638-1	1	90	4.5	0.8	66	1.2	1.5	1.5	0.85	4.5	30	8-lead LFCSP, 8-lead SOIC	EAR99

Overvoltage Protection/Over-the-Top (OVP/OTT) Amplifiers

Part Number	Number of Amps	Overvoltage Protection/Over-the-Top	Rail to Rail	V_S Span (min) (V)	V_S Span (max) (V)	V_{OS} (max) (μV)	V_{OS} TC (max) ($\mu\text{V}/^\circ\text{C}$)	I_{BIAS} (max) (nA)	GBP (typ) (MHz)	Slew Rate (typ) (V/ μs)	V_{NOISE} Density (typ) (nV/ $\sqrt{\text{Hz}}$)	0.1 Hz to 10 Hz V_{NOISE} (typ) ($\mu\text{V p-p}$)	I_O /Amp (typ) (mA)	Package	ECCN Code
LT1997-2 <i>New</i>	1	OTT	Both	3.3	50	80	1.5	55	1	0.75	37	0.9	3.85	16-lead MSOP (4 pins removed), 14-lead DFN	EAR99
ADA4091-2	2	OVP	Both	2.7	36	250		880	1.27	0.46	24	0.8	1.815	8-lead LFCSP, 8-lead SOIC	EAR99
ADA4091-4	4	OVP	Both	2.7	36	250		880	1.27	0.46	24	0.8	1.815	16-lead LFCSP, 14-lead TSSOP	EAR99
ADA4092-4	4	OVP	Both	2.7	36	1500		880	1.4	0.4	24	0.8	1.815	14-lead TSSOP	EAR99
ADA4096-2	2	OVP	Both	3	30	300		275	0.786	0.4	27	0.7	0.66	8-lead LFCSP, 8-lead MSOP	EAR99
ADA4096-4	4	OVP	Both	3	30	300		275	0.786	0.4	27	0.7	0.66	16-lead LFCSP, 14-lead TSSOP	EAR99
ADA4177-1	1	OVP		10	30	60	1	1	3.5	1.5	8	0.175	0.5	8-lead SOIC, 8-lead MSOP	EAR99
ADA4177-2	2	OVP		10	30	60	1	1	3.5	1.5	8	0.175	0.5	8-lead SOIC, 8-lead MSOP	EAR99
ADA4177-4	4	OVP		10	30	60	1	1	3.5	1.5	8	0.175	0.5	14-lead SOIC, 14-lead TSSOP	EAR99
LT1490A	2	OTT	Both	2	44	500	4	88	0.18	0.06	50	1	0.44	8-lead PDIP, 8-lead SOIC, 8-lead MSOP, 8-lead DFN	EAR99
LT1491A	4	OTT	Both	2	44	1000	4	88	0.18	0.06	50	1	0.44	14-lead PDIP, 14-lead SOIC, 16-lead DFN	EAR99
LT1494	1	OTT	Both	2.1	36	375	2	11	0.003	0.001	185	4	0.011	8-lead PDIP, 8-lead SOIC, 8-lead MSOP	EAR99
LT1495	2	OTT	Both	2.1	36	375	2	11	0.003	0.001	185	4	0.011	8-lead PDIP, 8-lead SOIC	EAR99
LT1496	4	OTT	Both	2.1	36	375	2	11	0.003	0.001	185	4	0.011	14-lead PDIP, 14-lead SOIC	EAR99
LT1636	1	OTT	Both	2.6	44	225	5	88	0.2	0.07	52	0.7	0.462	8-lead PDIP, 8-lead SOIC, 8-lead MSOP, 8-lead DFN	EAR99
LT1637	1	OTT	Both	2.7	44	350	3	550	1	0.35	27	0.6	2.09	8-lead PDIP, 8-lead SOIC, 8-lead MSOP, 8-lead DFN	EAR99
LT1638	2	OTT	Both	2.5	44	600	6	550	1.2	0.38	20	1	1.87	8-lead PDIP, 8-lead SOIC, 8-lead MSOP, 8-lead DFN	EAR99
LT1639	4	OTT	Both	2.5	44	600	6	550	1.075	0.38	20	1	1.87	14-lead PDIP, 14-lead SOIC	EAR99
LT1672	1	OTT	Both	2.1	36	375	2	11	0.012	0.005	185	4	0.017	8-lead PDIP, 8-lead SOIC, 8-lead MSOP	EAR99

Operational Amplifiers (Op Amps)

Overvoltage Protection/Over-the-Top (OVP/OTT) Amplifiers (Continued)

Part Number	Number of Amps	Overvoltage Protection/Over-the-Top	Rail to Rail	V _s Span (min) (V)	V _s Span (max) (V)	V _{os} (max) (μV)	V _{os} TC (max) (μV/°C)	I _{BIAS} (max) (nA)	GBP (typ) (MHz)	Slew Rate (typ) (V/μs)	V _{NOISE} Density (typ) (nV/√Hz)	0.1 Hz to 10 Hz V _{NOISE} (typ) (μV p-p)	I _o /Amp (typ) (mA)	Package	ECCN Code
LT1673	2	OTT	Both	2.1	36	375	2	11	0.012	0.005	185	4	0.017	8-lead PDIP, 8-lead SOIC	EAR99
LT1674	4	OTT	Both	2.1	36	375	2	11	0.012	0.005	185	4	0.017	14-lead PDIP, 14-lead SOIC	EAR99
LT1782	1	OTT	Both	2.2	18	800	5	165	0.2	0.07	50	1	0.44	5-lead SOT-23, 6-lead SOT-23	EAR99
LT1783	1	OTT	Both	2.2	18	800	5	880	1.25	0.42	20	0.6	2.31	5-lead SOT-23, 6-lead SOT-23	EAR99
LT1784	1	OTT	Both	2	18	3500	15	5500	2.5	2.1	25	1.5	5.5	5-lead SOT-23, 6-lead SOT-23	EAR99
LT1991	1	OTT	In to V-output	2.4	40	50	1	55	0.56	0.12	46	0.35	1.1	10-lead MSOP, 10-lead DFN	EAR99
LT1996	1	OTT	In to V-output	2.7	36	50	1	55	0.56	0.12	18	0.35	1.1	10-lead MSOP, 10-lead DFN	EAR99
LT1997-3	1	OTT	Both	3.3	50	60	1.5	55	1.1	0.75	50	1.4	3.85	16-lead MSOP (4 pins removed), 14-lead DFN	EAR99
LT6015	1	OTT	Both	3	50	50		55	3.2	0.75	18	0.5	3.465	5-lead SOT-23	EAR99
LT6016	2	OTT	Both	3	50	50		55	3.2	0.75	18	0.5	3.465	8-lead MSOP	EAR99
LT6017	4	OTT	Both	3	50	50		55	3.2	0.75	18	0.5	3.465	22-lead DFN	EAR99

High Voltage (V ≥30 V) Precision Amplifiers

Part Number	Number of Amps	V _s Span (min) (V)	V _s Span (max) (V)	I _o /Amp (typ) (mA)	V _{os} (max) (μV)	V _{os} TC (max) (μV/°C)	I _{BIAS} (max) (nA)	V _{NOISE} Density (typ) (nV/√Hz)	0.1 Hz to 10 Hz V _{NOISE} (typ) (μV p-p)	GBP (typ)	Slew Rate (typ)	Package	ECCN Code
LT1997-2 <i>New</i>	1	3.3	50	0.35	80	1.5	5	37	0.9	1	0.75	16-lead MSOP (4 pins removed), 14-lead DFN	EAR99
LTC2058 <i>New</i>	2	4.75	36	0.95	5	0.025	0.1	9	0.2	2.5	1.6	12-lead MSOP-EP, 8-lead SOIC-EP	EAR99
ADA4625-1 <i>New</i>	1	5	36	4	80	2.1	0.075	3.3	0.15	18	48	8-lead SOIC-EP	EAR99
LT6274 <i>New</i>	1	9	32	1.6	400	10	500	10	1	40	2200	5-lead SOT-23	EAR99
ADHV4702-1	1	24	220	3	1000	2	0.002	8		10	74	LFCSP: LEADFRM chip scale	EAR99
LTC6090	1	9.5	140	2.7	1000		0.05	14	3.5	12	24	16-lead TSSOP-EP, 8-lead SOIC-EP	EAR99
LTC6090-5	1	9.5	140	2.7	1000		0.05	14	3.5	24	37	16-lead TSSOP-EP, 8-lead SOIC-EP	EAR99
LTC6091	2	9.5	140	2.8	1000	5	0.05	14	3.5	12	21	16-lead QFN	EAR99
ADA4700-1	1	9	110	1.7	2000	13	30	14.7	0.8	3.5	20	8-lead SOIC-EP	EAR99
LTC2057HV	1	4.75	60	0.8	4	0.015	0.12	11	0.2	1.5	1.2	8-lead SOIC, 8-lead MSOP, 10-lead MSOP, 8-lead DFN	EAR99
ADA4522-1	1	4.5	55	0.84	5	0.015	0.15	5.8	0.117	2.7	1.7	8-lead SOIC, 8-lead MSOP	EAR99
ADA4522-2	2	4.5	55	0.83	5	0.015	0.15	5.8	0.117	2.7	1.7	8-lead SOIC, 8-lead MSOP	EAR99
ADA4522-4	4	4.5	55	0.83	5	0.015	0.15	5.8	0.117	2.7	1.7	14-lead SOIC, 14-lead TSSOP	EAR99
LT6015	1	3	50	0.315	50		5	18	0.5	3.2	0.75	5-lead SOT-23	EAR99
LT6016	2	3	50	0.315	50		5	18	0.5	3.2	0.75	8-lead MSOP	EAR99
LT6017	4	3	50	0.315	50		5	18	0.5	3.2	0.75	22-lead DFN	EAR99
LT1997-3	1	3.3	50	0.35	60	1.5	5	50	1.4	1.1	0.75	16-lead MSOP (4 pins removed), 14-lead DFN	EAR99
LT1178	2	2	44	0.012	70	3	5	49	0.9	0.085	0.04	8-lead PDIP, 8-lead SOIC, 16-lead SOIC	EAR99
LT1179	4	2	44	0.012	100	0.3	5	49	0.9	0.085	0.04	14-lead PDIP, 16-lead SOIC	EAR99
LT1490A	2	2	44	0.04	500	4	8	50	1	0.18	0.06	8-lead PDIP, 8-lead SOIC, 8-lead MSOP, 8-lead DFN	EAR99
LT1491A	4	2	44	0.04	1000	4	8	50	1	0.18	0.06	14-lead PDIP, 14-lead SOIC, 16-lead DFN	EAR99
LT1077	1	2.2	44	0.048	40	1.6	9	27	0.5	0.23	0.08	8-lead PDIP, 8-lead SOIC	EAR99
LT1078	2	2.2	44	0.038	70	1.8	8	28	0.6	0.2	0.07	8-lead PDIP, 8-lead SOIC, 16-lead SOIC	EAR99
LT1079	4	2.2	44	0.038	100	1.8	8	28	0.6	0.2	0.07	14-lead PDIP, 16-lead SOIC	EAR99
LT1079MJ	4	2.2	44	0.038	100	1.8	8	28	0.6	0.2	0.07	14-lead PDIP, 16-lead SOIC	EAR99
LT2178	2	2.2	44	0.013	70	1.8	5	49	0.9	0.06	0.025	8-lead SOIC	EAR99
LT2179	4	2.2	44	0.013	100	3	5	49	0.9	0.06	0.025	14-lead SOIC	EAR99

Operational Amplifiers (Op Amps)

High Voltage ($V \geq 30\text{ V}$) Precision Amplifiers (Continued)

Part Number	Number of Amps	V_s Span (min) (V)	V_s Span (max) (V)	I_o /Amp (typ) (mA)	V_{os} (max) (μV)	V_{os} TC (max) ($\mu\text{V}/^\circ\text{C}$)	I_{BIAS} (max) (nA)	V_{NOISE} Density (typ) ($\text{nV}/\sqrt{\text{Hz}}$)	0.1 Hz to 10 Hz V_{NOISE} (typ) ($\mu\text{V p-p}$)	GBP (typ)	Slew Rate (typ)	Package	ECCN Code
LT2078	2	2.3	44	0.035	70	1.8	8	28	0.6	0.2	0.07	8-lead SOIC	EAR99
LT2079	4	2.3	44	0.035	110	3	8	28	0.6	0.2	0.07	14-lead SOIC	EAR99
LT1638	2	2.5	44	0.17	600	6	50	20	1	1.2	0.38	8-lead PDIP, 8-lead SOIC, 8-lead MSOP, 8-lead DFN	EAR99
LT1639	4	2.5	44	0.17	600	6	50	20	1	1.075	0.38	14-lead PDIP, 14-lead SOIC	EAR99
LT1677	1	2.5	44	2.75	60	1.5	20	3.2	0.09	7.2	2.5	8-lead PDIP, 8-lead SOIC	EAR99
LT1637	1	2.7	44	0.19	350	3	50	27	0.6	1	0.35	8-lead PDIP, 8-lead SOIC, 8-lead MSOP, 8-lead DFN	EAR99
LT1006	1	4	44	0.34	50	1.3	15	22	0.55	0.6	0.4	8-lead PDIP, 8-lead SOIC	EAR99
LT1007	1	4	44	2.6	25	0.6	35	2.5	0.06	8	2.5	8-lead PDIP, 8-lead SOIC	EAR99
LT1013	2	4	44	0.35	150	2	20	22	0.55	0.8	0.4	8-lead TO-5 (0.200 in PCD), 8-lead PDIP, 8-lead SOIC	EAR99
LT1013AMH	2	4	44	0.35	150	2	20	22	0.55	0.8	0.4	8-lead TO-5 (0.200 in PCD), 8-lead PDIP, 8-lead SOIC	EAR99
LT1014	4	4	44	0.35	150	2	20	22	0.55	0.8	0.4	14-lead PDIP, 16-lead SOIC	EAR99
LT1001	1	6	44	1.5	25	0.6	2	9.6	0.3	0.8	0.25	8-lead PDIP, 8-lead SOIC	EAR99
LT1002	2	6	44	1.53	60	0.9	3	9.6	0.35	0.8	0.25	14-lead PDIP	EAR99
LT1124	2	8	44	2.3	70	1	20	2.7	0.07	12.5	4.5	8-lead PDIP, 8-lead SOIC	EAR99
LT1125	4	8	44	2.3	90	1	20	2.7	0.07	12.5	4.5	14-lead PDIP, 16-lead SOIC	EAR99
LT1128	1	8	44	7.4	40	0.8	90	0.85	0.035	20	6	8-lead PDIP, 8-lead SOIC	EAR99
LT1097	1	2	40	0.35	50	1.2	0.25	14	0.5	0.7	0.2	8-lead PDIP, 8-lead SOIC	EAR99
LT1112	2	2	40	0.35	60	0.5	0.25	14	0.3	0.75	0.3	8-lead PDIP, 8-lead SOIC	EAR99
LT1114	4	2	40	0.35	60	1.1	0.25	14	0.3	0.75	0.3	14-lead PDIP, 16-lead SOIC	EAR99
LT1012	1	2.4	40	0.37	25	0.6	0.1	14	0.5	1	0.2	8-lead PDIP, 8-lead SOIC	EAR99
LT1880	1	2.4	40	1.2	150	1.2	0.9	13	0.5	1.1	0.55	5-lead SOT-23	EAR99
LT1881	2	2.4	40	0.65	50	0.8	0.2	14	0.5	1	0.35	8-lead PDIP, 8-lead SOIC	EAR99
LT1882	4	2.4	40	0.65	80	0.8	0.5	14	0.5	1	0.35	14-lead SOIC	EAR99
LT1884	2	2.4	40	0.65	50	0.8	0.4	9.5	0.4	2	0.9	8-lead PDIP, 8-lead SOIC	EAR99
LT1885	4	2.4	40	0.65	80	0.8	0.9	9.5	0.4	2	0.9	14-lead SOIC	EAR99
LT1991	1	2.4	40	0.1	50	1	5	46	0.35	0.56	0.12	10-lead MSOP, 10-lead DFN	EAR99
LT6011	2	2.4	40	0.135	60	0.8	0.3	14	0.4	0.33	0.09	8-lead SOIC, 8-lead MSOP, 8-lead DFN	EAR99
LT6012	4	2.4	40	0.135	60	0.8	0.3	14	0.4	0.33	0.09	14-lead SOIC, 16-lead SSOP	EAR99
LT6010	1	2.7	40	0.135	35	0.8	0.11	14	0.4	0.33	0.09	8-lead SOIC, 8-lead DFN	EAR99
LT6013	1	2.7	40	0.145	35	0.8	0.25	9.5	0.2	1.6	0.2	8-lead SOIC, 8-lead DFN	EAR99
LT6014	2	2.7	40	0.145	60	0.8	0.4	9.5	0.2	1.6	0.2	8-lead SOIC, 8-lead DFN	EAR99
LT1008	1	4	40	0.38	120	1.5	0.1	14	0.5	1	0.2	8-lead PDIP, 8-lead SOIC	EAR99
LT1024	2	4	40	0.38	50	1.5	0.12	14	0.5	1	0.2	14-lead PDIP	EAR99
LT1055	1	8	40	2.8	700	12	0.05	15	2	4.5	12	8-lead PDIP, 8-lead SOIC	EAR99
LT1056	1	8	40	5	800	12	0.05	15	2.8	5.5	14	8-lead PDIP, 8-lead SOIC	EAR99
LT1057	2	8	40	1.6	450	10	0.05	13	2	5	14	8-lead PDIP, 8-lead SOIC	EAR99
LT1058	4	8	40	1.6	600	15	0.05	13	2.4	5	14	14-lead PDIP, 16-lead SOIC	EAR99
LT1457	2	9	40	1.8	450	10	0.5	13	2	1	4	8-lead PDIP, 8-lead SOIC	EAR99
LT1462	2	10	40	0.028	800	20	0.002	76	2	0.175	0.13	8-lead PDIP, 8-lead SOIC	EAR99
LT1463	4	10	40	0.028	800	20	0.002	76	2	0.175	0.13	14-lead PDIP, 14-lead SOIC	EAR99
LT1464	2	10	40	0.145	800	20	0.002	24	2	1	0.9	8-lead PDIP, 8-lead SOIC	EAR99
LT1465	4	10	40	0.145	800	20	0.002	24	2	1	0.9	14-lead PDIP, 14-lead SOIC	EAR99
LT1792	1	10	40	4.2	600	10	0.8	4.2	2.4	5.6	3.4	8-lead PDIP, 8-lead SOIC	EAR99
LT1793	1	10	40	4.2	800	13	0.01	6	2.4	4.2	3.4	8-lead PDIP, 8-lead SOIC	EAR99
LT1022	1	20	40	5.2	250	5	0.05	14	2.5	8.5	26	8-lead TO-5 (0.200 in PCD), 8-lead PDIP	EAR99
LT1122	1	20	40	7.5	600	18	0.075	14	3	14	80	8-lead PDIP, 8-lead SOIC	EAR99
LT1218	1	2	36	0.37	90	3	70	33		0.3	0.1	8-lead PDIP, 8-lead SOIC	EAR99
LT1219	1	2	36	0.37	90	3	70	33		0.15	0.05	8-lead PDIP, 8-lead SOIC	EAR99
LT1366	2	2	36	0.34	475	6	35	29		0.4	0.13	8-lead PDIP, 8-lead SOIC	EAR99
LT1367	4	2	36	0.34	800	6	35	29		0.4	0.13	14-lead SOIC	EAR99
LT1368	2	2	36	0.34	475	6	35	29		0.16	0.065	8-lead PDIP, 8-lead SOIC	EAR99
LT1369	4	2	36	0.34	800	6	35	29		0.16	0.065	14-lead SOIC	EAR99
LT1492	2	2.1	36	0.425	180	3	100	16.5	0.33	4.5	1.8	8-lead PDIP, 8-lead SOIC	EAR99

Operational Amplifiers (Op Amps)

High Voltage ($V \geq 30$ V) Precision Amplifiers (Continued)

Part Number	Number of Amps	V_s Span (min) (V)	V_s Span (max) (V)	I_o /Amp (typ) (mA)	V_{os} (max) (μ V)	V_{os} TC (max) (μ V/ $^{\circ}$ C)	I_{BIAS} (max) (nA)	V_{NOISE} Density (typ) (nV/ \sqrt Hz)	0.1 Hz to 10 Hz V_{NOISE} (typ) (μ V p-p)	GBP (typ)	Slew Rate (typ)	Package	ECCN Code
LT1493	4	2.1	36	0.425	130	3	100	16.5	0.33	4.5	1.8	16-lead SOIC	EAR99
LT1494	1	2.1	36	0.001	375	2	1	185	4	0.003	0.001	8-lead PDIP, 8-lead SOIC, 8-lead MSOP	EAR99
LT1495	2	2.1	36	0.001	375	2	1	185	4	0.003	0.001	8-lead PDIP, 8-lead SOIC	EAR99
LT1496	4	2.1	36	0.001	375	2	1	185	4	0.003	0.001	14-lead PDIP, 14-lead SOIC	EAR99
LT1672	1	2.1	36	0.002	375	2	1	185	4	0.012	0.005	8-lead PDIP, 8-lead SOIC, 8-lead MSOP	EAR99
LT1673	2	2.1	36	0.002	375	2	1	185	4	0.012	0.005	8-lead PDIP, 8-lead SOIC	EAR99
LT1674	4	2.1	36	0.002	375	2	1	185	4	0.012	0.005	14-lead PDIP, 14-lead SOIC	EAR99
LT1498	2	2.2	36	1.7	475	2.5	650	12	0.4	10.5	4.5	8-lead PDIP, 8-lead SOIC	EAR99
LT1499	4	2.2	36	1.7	475	2.5	650	12	0.4	10.5	4.5	14-lead SOIC	EAR99
LT1211	2	2.5	36	1.3	150	1.5	100	12	0.25	13	7	8-lead PDIP, 8-lead SOIC	EAR99
LT1211MJ8	2	2.5	36	1.3	150	1.5	100	12	0.25	13	7	8-lead PDIP, 8-lead SOIC	EAR99
LT1212	4	2.5	36	1.3	275	3	125	12	0.25	13	7	14-lead PDIP, 16-lead SOIC	EAR99
LT1213	2	2.5	36	2.7	150	1.5	160	10	0.2	28	8.5	8-lead PDIP, 8-lead SOIC	EAR99
LT1213MJ8	2	2.5	36	2.7	150	1.5	160	10	0.2	28	8.5	8-lead PDIP, 8-lead SOIC	EAR99
LT1214	4	2.5	36	2.7	275	3	200	10	0.2	28	8.5	14-lead PDIP, 16-lead SOIC	EAR99
LT1215	2	2.5	36	4.75	300	2.5	500	12	0.4	23	30	8-lead PDIP, 8-lead SOIC	EAR99
LT1216	4	2.5	36	4.75	450	5	600	12	0.4	23	30	14-lead PDIP, 16-lead SOIC	EAR99
LT1630	2	2.6	36	3.5	525	5.5	1000	6	0.3	30	9.2	8-lead PDIP, 8-lead SOIC	EAR99
LT1631	4	2.6	36	3.5	525	5.5	1000	6	0.3	30	9.2	14-lead SOIC	EAR99
ADA4091-2	2	2.7	36	0.165	250		80	24	0.8	1.27	0.46	8-lead LFCSP, 8-lead SOIC	EAR99
ADA4091-4	4	2.7	36	0.165	250		80	24	0.8	1.27	0.46	16-lead LFCSP, 14-lead TSSOP	EAR99
LT1996	1	2.7	36	0.1	50	1	5	18	0.35	0.56	0.12	10-lead MSOP, 10-lead DFN	EAR99
AD8244	4	3	36	0.18	350	3	0.003	13	0.4		0.8	10-lead MSOP	EAR99
LT1360	1	3	36	3.8	1000	12	1000	9		50	800	8-lead PDIP, 8-lead SOIC	EAR99
LT1678	2	3	36	2	100	3	20	3.9	0.09	20	6	8-lead SOIC	EAR99
LT1679	4	3	36	2	100	3	20	3.9		20	6	14-lead SOIC	EAR99
AD704	4	4	36	0.6	150	1.5	0.27	15	0.5	0.8	0.15	20-lead LCC, 14-lead PDIP, 16-lead SOIC—wide	EAR99
AD706	2	4	36	0.6	100	1.5	0.2	15	0.5	0.8	0.15	8-lead PDIP, 8-lead SOIC	EAR99
LTC1151	2	4.75	36	0.9	5	0.05	0.1		1.5	2	2.5	8-lead PDIP, 16-lead SOIC	EAR99
LTC2057	1	4.75	36	0.8	4	0.015	0.12	11	0.2	1.5	1.2	8-lead SOIC, 8-lead MSOP, 10-lead MSOP, 8-lead DFN	EAR99
AD8622	2	5	36	0.215	125	1.2	0.2	11	0.2	0.56	0.48	8-lead SOIC, 8-lead MSOP	EAR99
AD8624	4	5	36	0.215	125	1.2	0.2	11	0.2	0.56	0.48	16-lead LFCSP, 14-lead TSSOP	EAR99
LT1220	1	5	36	8	1000		300	17		45	250	8-lead PDIP, 8-lead SOIC	EAR99
LT1351	1	5	36	0.25	600	8	50	14		3	200	8-lead PDIP, 8-lead SOIC, 8-lead MSOP	EAR99
LT1352	2	5	36	0.25	600	8	50	14		3	200	8-lead PDIP, 8-lead SOIC	EAR99
LT1353	4	5	36	0.25	600	8	50	14		3	200	14-lead SOIC	EAR99
LT1354	1	5	36	1	800	8	300	10		12	400	8-lead PDIP, 8-lead SOIC	EAR99
LT1355	2	5	36	1	800	8	300	10		12	400	8-lead PDIP, 8-lead SOIC	EAR99
LT1356	4	5	36	1	800	8	300	10		12	400	14-lead PDIP, 16-lead SOIC	EAR99
LT1357	1	5	36	2	600	8	500	8		25	600	8-lead PDIP, 8-lead SOIC	EAR99
LT1358	2	5	36	2	600	8	500	8		25	600	8-lead PDIP, 8-lead SOIC	EAR99
LT1359	4	5	36	2	600	8	500	8		25	600	14-lead PDIP, 14-lead SOIC, 16-lead SOIC	EAR99
LT1361	2	5	36	3.8	1000	12	1000	9		50	800	8-lead PDIP, 8-lead SOIC	EAR99
LT1362	4	5	36	3.8	1000	12	1000	9		50	800	14-lead PDIP, 16-lead SOIC	EAR99
LT1970	1	5	36	7	600	10	600	15	3	3.6	1.6	20-lead TSSOP-EP	EAR99
LT1970A	1	5	36	7	600	10		15		3.6	1.6	20-lead TSSOP-EP	EAR99
AD708	2	6	36	2.75	30	1	1	9.6	0.23	0.9	0.3	8-lead PDIP, 8-lead CerDIP	EAR99
AD795	1	8	36	1.5	500	10	0.002	9	1	1.6	1	8-lead SOIC	EAR99
AD8671	1	8	36	3.5	75	0.5	12	2.8	0.077	10	4	8-lead SOIC, 8-lead MSOP	EAR99
AD8672	2	8	36	3.5	75	0.8	12	2.8	0.077	10	4	8-lead SOIC, 8-lead MSOP	EAR99
AD8674	4	8	36	3.5	75	0.8	12	2.8	0.077	10	4	14-lead SOIC, 14-lead TSSOP	EAR99
AD8677	1	8	36	1.3	130	1.5	1	10	0.25	0.6	0.2	8-lead SOIC, 5-lead TSOT	EAR99

Operational Amplifiers (Op Amps)

High Voltage ($V \geq 30\text{ V}$) Precision Amplifiers (Continued)

Part Number	Number of Amps	V_s Span (min) (V)	V_s Span (max) (V)	I_q /Amp (typ) (mA)	V_{os} (max) (μV)	V_{os} TC (max) ($\mu\text{V}/^\circ\text{C}$)	I_{BIAS} (max) (nA)	V_{NOISE} Density (typ) (nV/ $\sqrt{\text{Hz}}$)	0.1 Hz to 10 Hz V_{NOISE} (typ) ($\mu\text{V p-p}$)	GBP (typ)	Slew Rate (typ)	Package	ECCN Code
AD648	2	9	36	0.17	1000	10	0.01	30		1	1.8	8-lead PDIP, 8-lead SOIC	EAR99
AD711	1	9	36	2.8	1000	20	0.05	16	2	4	20	8-lead PDIP, 8-lead CerDIP, 8-lead SOIC	EAR99
AD712	2	9	36	2.8	1000	20	0.075	16	2	4	20	8-lead PDIP, 8-lead CerDIP, 8-lead SOIC	EAR99
AD744	1	9	36	3.5	500	10	0.1	16	2	13	75	Round header/metal CAN, 8-lead PDIP, 8-lead CerDIP, 8-lead SOIC, chips or die	EAR99
AD843	1	9	36	12	1000		1	19		34	250	8-lead PDIP, 14-lead CerDIP, 8-lead CerDIP, 16-lead SOIC—wide, LCC:cer leadless chip carr, chips or die	EAR99
AD844	1	9	36	6.5	150		250	2			2000	8-lead PDIP, 8-lead CerDIP, 16-lead SOIC—wide, chips or die	EAR99
AD847	1	9	36	4.8	1000		6600	15		50	300	8-lead PDIP, 8-lead CerDIP, 8-lead SOIC, chips or die	EAR99
AD8599	2	9	36	5.7	120	2.2	200	1.07	0.076	10	16	8-lead SOIC	EAR99
AD8682	2	9	36	0.21	1000		0.02	36	1.3	3.5	9	8-lead SOIC, 8-lead MSOP	EAR99
AD8684	4	9	36	0.21	1000		0.02	36	1.3	3.5	9	14-lead SOIC, 14-lead TSSOP	EAR99
ADA4075-2	2	9	36	2.25	1000		100	2.8	0.06	6.5	12	8-lead LFCSP, 8-lead SOIC	EAR99
ADA4627-1	1	9	36	7	200	2	0.005	4.8	0.7	19	56	8-lead LFCSP, 8-lead SOIC	EAR99
ADA4898-1	1	9	36	8.1	125		400	0.9		50	55	8-lead SOIC-EP	EAR99
ADA4898-2	2	9	36	7.9	125		400	0.9		50	55	8-lead SOIC-EP	EAR99
AD845	1	9.5	36	10	250	5	1	12	4	16	100	8-lead PDIP, 8-lead CerDIP, 16-lead SOIC—wide, chips or die	EAR99
AD743	1	9.6	36	10	1000		0.4	2.9	0.38	4.5	2.8	16-lead SOIC—wide	EAR99
AD745	1	9.6	36	10	500		0.25	2.9	0.38	20	12.5	16-lead SOIC—wide	EAR99
AD549	1	10	36	0.7	500	15	0.00006	35	4	1	3	8-lead header	EAR99
AD841	1	10	36	11	1000		5000	15		40	300	20-lead LCC, 14-lead PDIP, 14-lead CerDIP, LCC:cer leadless chip carr, chips or die	EAR99
ADA4610-1	1	10	36	1.6	400	4	0.025	7.3	0.45	16.3	25	8-lead SOIC, 5-lead SOT-23	EAR99
ADA4610-2	2	10	36	1.6	400	4	0.025	7.3	0.45	16.3	25	8-lead LFCSP, 8-lead SOIC, 8-lead MSOP	EAR99
ADA4610-4	4	10	36	1.6	400	8	0.025	7.3	0.45	16.3	25	16-lead LFCSP, 14-lead SOIC	EAR99
LT6018	1	8	33	7.2	50	0.5	150	1.2	0.03	15	30	8-lead SOIC-EP, 12-lead DFN	EAR99
LTC1150	1	4.75	32	0.8	10	0.05	0.1		1.8	2.5	3	8-lead PDIP, 8-lead SOIC	EAR99
LT6275	2	9	32	1.6	400	10	500	10	1	40	2200	8-lead MSOP	EAR99
AD8634	2	3	30	1.1	250		200	4.2	0.13	9.7	5	Chips or die, 8-lead flatpack, 8-lead SOIC	EAR99
ADA4084-1	1	3	30	0.625	100	1.75	250	3.9	0.1	15.9	4.6	8-lead SOIC, 5-lead SOT-23	EAR99
ADA4084-2	2	3	30	0.625	100	1.75	250	3.9	0.1	15.9	4.6	8-lead LFCSP, 8-lead SOIC, 8-lead MSOP	EAR99
ADA4084-4	4	3	30	0.625	100	1.75	250	3.9	0.1	15.9	4.6	16-lead LFCSP, 14-lead TSSOP	EAR99
ADA4096-2	2	3	30	0.06	300		25	27	0.7	0.786	0.4	8-lead LFCSP, 8-lead MSOP	EAR99
ADA4096-4	4	3	30	0.06	300		25	27	0.7	0.786	0.4	16-lead LFCSP, 14-lead TSSOP	EAR99
LT6020	2	3	30	0.09	30	0.5	1	50	1.1	0.4	5	8-lead MSOP, 8-lead DFN, 10-lead DFN	EAR99
LT6020-1	2	3	30	0.09	30	0.5	1	50	1.1	0.4	5	8-lead MSOP, 8-lead DFN, 10-lead DFN	EAR99
LT6023	2	3	30	0.018	30	2.9	3	132		0.04	1.45	8-lead MSOP, 8-lead DFN, 10-lead DFN	EAR99
LT6023-1	2	3	30	0.018	30	2.9	3	132		0.04	1.45	8-lead MSOP, 8-lead DFN, 10-lead DFN	EAR99
ADA4638-1	1	4.5	30	0.85	4.5	0.8	0.09	66	1.2	1.5	1.5	8-lead LFCSP, 8-lead SOIC	EAR99
AD820	1	5	30	0.9	1000		0.01	13	2	1.8	3	8-lead PDIP, 8-lead SOIC, 8-lead MSOP	EAR99
ADA4077-1	1	5	30	0.4	35	0.25	1	7	0.25	3.9	1	8-lead SOIC, 8-lead MSOP	EAR99
ADA4077-2	2	5	30	0.4	35	0.25	1	7	0.25	3.9	1	8-lead SOIC, 8-lead MSOP	EAR99
ADA4077-4	4	5	30	0.4	50	0.75	1	7	0.25	3.9	1	14-lead SOIC, 14-lead TSSOP	EAR99
ADA4622-1	1	5	30	0.715	350	5	0.01	12.5	0.75	8	23	8-lead SOIC, 5-lead SOT-23	EAR99

Operational Amplifiers (Op Amps)

High Voltage ($V \geq 30$ V) Precision Amplifiers (Continued)

Part Number	Number of Amps	V_s Span (min) (V)	V_s Span (max) (V)	I_o /Amp (typ) (mA)	V_{os} (max) (μ V)	V_{os} TC (max) (μ V/ $^{\circ}$ C)	I_{BIAS} (max) (nA)	V_{NOISE} Density (typ) (nV/ \sqrt Hz)	0.1 Hz to 10 Hz V_{NOISE} (typ) (μ V p-p)	GBP (typ)	Slew Rate (typ) (V/ μ s)	Package	ECCN Code
ADA4622-2	2	5	30	0.665	350	5	0.01	12.5	0.75	8	23	8-lead LFCSP, 8-lead SOIC, 8-lead MSOP	EAR99
ADA4622-4	4	5	30	0.665	350	5	0.01	12.5	0.75	8	23	16-lead LFCSP, 14-lead SOIC	EAR99
AD8510	1	9	30	2.5	400	5	0.08	7.6		8	20	8-lead SOIC, 8-lead MSOP	EAR99
AD8512	2	9	30	2.5	400	5	0.08	7.6		8	20	8-lead SOIC, 8-lead MSOP	EAR99
AD8513	4	9	30	2.5	1000	5	0.08	7.6		8	20	14-lead SOIC, 14-lead TSSOP	EAR99
AD8597	1	9	30	5.7	120	2.2	200	1.07	0.076	10	16	8-lead LFCSP, 8-lead SOIC	EAR99
AD8675	1	10	30	2.9	75	0.6	2	2.8	0.1	10	2.5	8-lead SOIC, 8-lead MSOP	EAR99
AD8676	2	10	30	2.9	50	0.6	2	2.8	0.1	10	2.5	8-lead SOIC, 8-lead MSOP	EAR99
ADA4004-1	1	10	30	2.2	125	1	90	1.8	0.15	12	2.7	8-lead SOIC, 5-lead SOT-23	EAR99
ADA4004-2	2	10	30	2.2	125	1	90	1.8	0.15	12	2.7	8-lead SOIC, 8-lead MSOP	EAR99
ADA4004-4	4	10	30	2.2	125	1	90	1.8	0.15	12	2.7	16-lead LFCSP, 14-lead SOIC	EAR99
ADA4177-1	1	10	30	0.5	60	1	1	8	0.175	3.5	1.5	8-lead SOIC, 8-lead MSOP	EAR99
ADA4177-2	2	10	30	0.5	60	1	1	8	0.175	3.5	1.5	8-lead SOIC, 8-lead MSOP	EAR99
ADA4177-4	4	10	30	0.5	60	1	1	8	0.175	3.5	1.5	14-lead SOIC, 14-lead TSSOP	EAR99
LT1007X		10	30	2.8	160		95			8	1.2	8-lead TO-5 (0.200 in PCD)	EAR99

High Voltage ($V \geq 30$ V), High Speed Amplifiers

Part Number	Number of Amps	V_s Span (min) (V)	V_s Span (max) (V)	I_o /Amp (typ) (mA)	V_{os} (max) (μ V)	V_{os} TC (max) (μ V/ $^{\circ}$ C)	I_{BIAS} (max) (nA)	V_{NOISE} Density (typ) (nV/ \sqrt Hz)	0.1 Hz to 10 Hz V_{NOISE} (typ) (μ V p-p)	GBP (MHz)	Slew Rate (typ) (V/ μ s)	Package	ECCN Code
LT1028	1	8	44	7.4	40	0.8	90	0.85	0.035	75	15	8-lead PDIP, 8-lead SOIC, 16-lead SOIC	EAR99
LT1115	1	8	44	8.5	200		380	0.9		70	15	8-lead PDIP, 16-lead SOIC	EAR99
LT1126	2	8	44	2.6	70	1	20	2.7	0.07	65	11	8-lead PDIP, 8-lead SOIC	EAR99
LT1127	4	8	44	2.6	90	1	20	2.7	0.07	65	11	14-lead PDIP, 16-lead SOIC	EAR99
LT1037	1	8	44	2.6	25	0.6	35	2.5	0.06	60	15	8-lead PDIP, 8-lead SOIC	EAR99
ADA4870	1	10	40	32.5	10,000		23000	2.1			2500	PSOP_3 430 mil with heatsink, chips or die	EAR99
LT1226	1	5	36	7	1000		8000	2.6		1000	400	8-lead PDIP, 8-lead SOIC	EAR99
AD829	1	9	36	5.3	1000		7000	1.7		750	230	20-lead LCC, 8-lead PDIP, 8-lead CerDIP, 8-lead SOIC, chips or die	EAR99
LT1222	1	5	36	8	300		300	3		500	200	8-lead PDIP, 8-lead SOIC	EAR99
LT1468-2	1	10	36	3.9	75		10	5	0.3	200	30	8-lead SOIC, 8-lead DFN	EAR99
LT1469-2	2	10	36	4.1	125		10	5	0.3	200	30	8-lead SOIC, 12-lead DFN	EAR99
LT1794	2	8	36	10	5000		4000	8		200	600	20-lead SOIC, 20-lead TSSOP-EP	EAR99
AD848	1	9	36	4.8	2300		5000	5		175	300	8-lead PDIP, 8-lead CerDIP, 8-lead SOIC, chips or die	EAR99
LT1203	1	9	36	10	30,000		5000			150	300	8-lead PDIP, 8-lead SOIC	EAR99
LT1205	2	9	36	10	30,000		5000			150	300	16-lead SOIC	EAR99
LT1221	1	5	36	8	1000		300	6		150	250	8-lead PDIP, 8-lead SOIC	EAR99
LT1225	1	5	36	7	1000		8000	7.5		150	400	8-lead PDIP, 8-lead SOIC	EAR99
LT1227	1	4	36	10	10,000			3.2		140	1100	8-lead PDIP, 8-lead SOIC	EAR99
LT1259	2	4	36	5	12,000			3.6		130	1600	14-lead PDIP, 14-lead SOIC	EAR99
LT1260	3	4	36	5	12,000			3.6		130	1600	16-lead PDIP, 16-lead SOIC	EAR99
AD797	1	10	36	10.5	40	1	900	0.9	0.05	110	20	8-lead PDIP, 8-lead SOIC	EAR99
AD818	1	5	36	7	2000		6600	10		100	500	8-lead PDIP, 8-lead SOIC	EAR99
AD828	2	5	36	7.5	2000		6600	10		100	450	8-lead PDIP, 8-lead SOIC	EAR99
LT1223	1	5	36	6	3000			33		100	1000	8-lead PDIP, 8-lead SOIC	EAR99
LT1227MJ8	1	4	36	10	10,000			3.2		100	1100	8-lead PDIP, 8-lead SOIC	EAR99
LT1228	1	4	36	9	5000		1000	20		100	500	8-lead PDIP, 8-lead SOIC	EAR99
LT1229	2	4	36	6	10,000			3.2		100	700	8-lead PDIP, 8-lead SOIC	EAR99
LT1230	4	4	36	6	10,000			3.2		100	700	14-lead PDIP, 14-lead SOIC	EAR99
LT1204	1	9	36	19	14,000			7		95	1000	16-lead PDIP, 16-lead SOIC	EAR99
LT1469	2	6	36	4.1	125	3	40	5	0.3	90	22	8-lead PDIP, 8-lead SOIC, 12-lead DFN	EAR99
AD810	1	5	36	6.8	6000		10,000	2.9		80	1000	8-lead PDIP, 8-lead CerDIP, 8-lead SOIC, chips or die	EAR99

Operational Amplifiers (Op Amps)

High Voltage ($V \geq 30\text{ V}$), High Speed Amplifiers (Continued)

Part Number	Number of Amps	V_s Span (min) (V)	V_s Span (max) (V)	I_Q /Amp (typ) (mA)	V_{OS} (max) (μV)	V_{OS} TC (max) ($\mu\text{V}/^\circ\text{C}$)	I_{BIAS} (max) (nA)	V_{NOISE} Density (typ) ($\text{nV}/\sqrt{\text{Hz}}$)	0.1 Hz to 10 Hz V_{NOISE} (typ) ($\mu\text{V p-p}$)	GBP (typ) (MHz)	Slew Rate (typ) ($\text{V}/\mu\text{s}$)	Package	ECCN Code
AD842	1	10	36	13	1000		5000	9		80	375	14-lead PDIP, 14-lead CerDIP, 16-lead SOIC—wide, LCC:cer leadless chip carr, chips or die	EAR99
LT1363	1	3	36	6.3	1500	13	2000	9		70	1000	8-lead PDIP, 8-lead SOIC	EAR99
LT1364	2	3	36	6	1500	13	1000	9		70	1000	8-lead PDIP, 8-lead SOIC	EAR99
LT1365	4	3	36	6	1500	13	2000	9		70	1000	14-lead PDIP, 16-lead SOIC	EAR99
LT1206	1	10	36	20	10,000			3.6		66	900	Round header/metal CAN, 7-lead DD PAK, 8-lead PDIP, 8-lead SOIC	EAR99
LT1207	2	10	36	20	10,000			3.6		66	900	16-lead SOIC	EAR99
LT1210	1	8	36	35	15,000			3		66	900	7-lead TO-220 (flow 06), round header/metal CAN, 7-lead DD PAK, 7-lead TO-220 (flow 44), 7-lead TO-220 (flow 37), 16-lead SOIC	EAR99
LT1795	2	10	36	29	13,000			3.6		65	900	20-lead SOIC, 20-lead TSSOP-EP	EAR99
LT1497	2	4	36	6	15,000			3		59	900	16-lead SOIC, 8-lead SOIC	EAR99
AD811	1	9	36	14.5	3000		5000	1.9			400	20-lead LCC, 8-lead PDIP, 8-lead CerDIP, 8-lead SOIC, 16-lead SOIC—wide, LCC:CER leadless chip, carr chips or die	EAR99
AD812	2	2.4	36	4.5	5000		25,000	3.5			250	8-lead PDIP, 8-lead SOIC	EAR99
AD813	3	2.4	36	4.5	5000		30,000	3.5			450	14-lead PDIP, 14-lead SOIC, chips or die, LCC:cer leadless chip carr	EAR99
AD815	2	10	36	15	8000		5000	1.85			900		EAR99
AD8244	4	3	36	0.18	350	3	0.003	13	0.4		0.8	10-lead MSOP	EAR99
AD844	1	9	36	6.5	150		250	2			2000	8-lead PDIP, 8-lead CerDIP, 16-lead SOIC—wide, chips or die	EAR99
ADA4637-1	1	9	30	7	200	2	0.005	4.8	0.7	79.9	170	8-lead LFCSF, 8-lead SOIC	EAR99
LT1210X	1	10	30	35	15,000			3		66	900	16-lead TSSOP-EP	EAR99

Operational Amplifiers (Op Amps)

LT6274/LT6275: 90 MHz, 2200 V/ μ s, 30 V Low Power Single/Dual Op Amps

Key Features

- ▶ 2200 V/ μ s slew rate
- ▶ 90 MHz, -3 dB bandwidth ($A_V = +1$)
- ▶ 40 MHz gain-bandwidth product
- ▶ 1.6 mA supply current per amplifier
- ▶ C-Load™ op amp drives all capacitive loads
- ▶ ± 4.5 V to ± 16 V operating supply range
- ▶ Unity-gain stable
- ▶ 10 nV/ $\sqrt{\text{Hz}}$ input noise voltage
- ▶ 400 μ V maximum input offset voltage
- ▶ 74 dB minimum open-loop gain, $R_L = 1$ k
- ▶ 40 ns settling time to 1%, 10 V step
- ▶ Specified at ± 5 V and ± 15 V
- ▶ Single in 5-lead TSOT-23 package
- ▶ Dual in 8-lead MSOP package

Key Benefits

- ▶ Combination of high bandwidth and fast slew rate enables low distortion, large signal amplification at high frequencies
- ▶ Are stable with any capacitive load making them useful in buffer or cable driving

Applications

- ▶ Wideband large signal amplification
- ▶ Cable drivers
- ▶ Buffers
- ▶ Automated test equipment
- ▶ Data acquisition systems
- ▶ Active filters
- ▶ High fidelity video and audio amplification

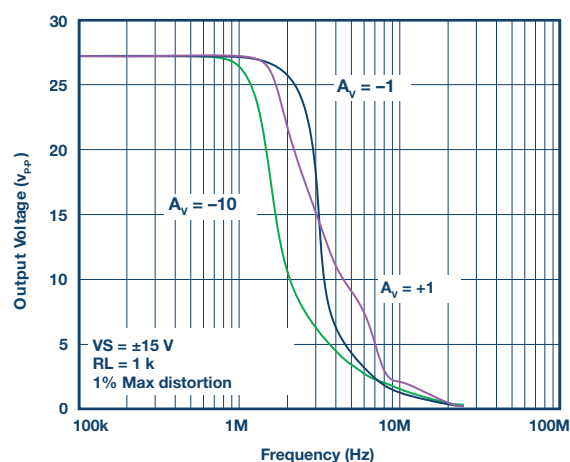

High Speed ($BW \geq 50$ MHz) Amplifiers

Part Number	Number of Amps	GBP (typ) (MHz)	Slew Rate (typ) (V/ μ s)	I_{bias} (typ) (nA)	V_{os} (typ) (μ V)	V_{noise} Density (typ) (mV/ $\sqrt{\text{Hz}}$)	I_o /Amp (typ) (mA)	V_o Span (min) (V)	V_o Span (max) (V)	Package	ECCN Code
LT6274 <i>New</i>	1	40	2200	100	150	10	1.6	9	32	5-lead SOT-23	EAR99
LTC6268-10	1	4000	1500	0.000003	200	4	16.5	3.1	5.25	8-lead SOIC, 6-lead SOT-23	EAR99
LTC6269-10	2	4000	1500	0.000003	200	4	16.5	3.1	5.25	8-lead MSOP-EP, 10-lead DFN	EAR99
LTC6410-6	1	1400	1500		400		104	2.8	5.5	16-lead QFN	EAR99
LT5514	1	850					148	4.75	5.25	20-lead TSSOP-EP	EAR99
LT1993-2	1	800	1100		1000	3.5	100	4	5.5	16-lead QFN	EAR99
LT6556	3	750	2100		18,000	11	9.5	4.5	12.6	24-lead SSOP, 24-lead QFN	EAR99
LT1886	2	700	200	1500	1000	6	7	4	13.2	8-lead SOIC	EAR99
LT1969	2	700	200	1500	1000	6	7	4	13.2	10-lead MSOP	EAR99
LT6411	2	650	3300		3000	8	16	4.5	12.6	16-lead QFN	EAR99
LT6553	3	650	2500	17,000	3000	9	8	4	13.2	16-lead SSOP	EAR99
LT6554	3	650	2500	17,000	11,000	20	8	4	13.2	16-lead SSOP	EAR99
LT6555	3	650	2200		5000	9	9	4.5	12.6	24-lead SSOP, 24-lead QFN	EAR99
AD8074	3	600	1600	5000	2500	19.5	24	9	11	16-lead TSSOP	EAR99
ADA4858-3	3	600	600	8000	500	4	19	3	5.5	16-lead LFCSP	EAR99
AD8075	3	550	1350	5000	2500	22	24	9	11	16-lead TSSOP	EAR99
LT6558	3	550	2200		12,000		22.5	3	7.5	16-lead SSOP, 16-lead DFN	EAR99
LT5524	1	540					75	4.75	5.25	20-lead TSSOP-EP	EAR99
LT6557	3	500	2200	70,000	12,000	12	22.5	3	7.5	16-lead SSOP, 16-lead DFN	EAR99
LTC6268	1	500	400	0.000003	200	4.3	16.5	3.1	5.25		EAR99
LTC6269	2	500	400	0.000003	200	4.3	16.5	3.1	5.25	8-lead MSOP-EP, 10-lead DFN	EAR99

Operational Amplifiers (Op Amps)

High Speed (BW ≥50 MHz) Amplifiers (Continued)

Part Number	Number of Amps	GBP (typ) (MHz)	Slew Rate (typ) (V/μs)	I _{BIAS} (typ) (nA)	V _{OS} (typ) (μV)	V _{NOISE} Density (typ) (nV/√Hz)	I _O /Amp (typ) (mA)	V _S Span (min) (V)	V _S Span (max) (V)	Package	ECCN Code
ADA4817-1	1	410	870	0.002	400	4	19	5	10	8-lead LFCSP, 8-lead SOIC-EP	EAR99
ADA4817-2	2	410	870	0.002	400	4	19	5	10	16-lead LFCSP	EAR99
ADA4857-1	1	410	2800	2000	2000	4.4	5	4.5	10.5	8-lead LFCSP, 8-lead SOIC	EAR99
ADA4857-2	2	410	2800	2000	2000	4.4	5	4.5	10.5	16-lead LFCSP	EAR99
LT1395	1	400	800		10,000	4.5	4.6	3	12.6	8-lead SOIC, 5-lead SOT-23, 6-lead SOT-23	EAR99
LT1396	2	400	800		10,000	4.5	4.6	3	12.6	8-lead SOIC, 8-lead MSOP, 8-lead DFN	EAR99
LT1397	4	400	800		10,000	4.5	4.6	3	12.6	14-lead SOIC, 16-lead SSOP, 14-lead DFN	EAR99
LT1818	1	400	2500	2000	200	6	9	3.5	12.6	8-lead SOIC, 5-lead SOT-23	EAR99
LT1819	2	400	2500	2000	200	6	9	3.5	12.6	8-lead SOIC, 8-lead MSOP	EAR99
LT1192	1	350	450	500	200	9	32	4	18	8-lead PDIP, 8-lead SOIC	EAR99
LT1194	1	350	500	500	1000	15	35	4	18	8-lead PDIP, 8-lead SOIC	EAR99
LT1806	1	325	125	1000	100	3.5	9	2.5	12.6	8-lead SOIC, 6-lead SOT-23	EAR99
LT1807	2	325	125	1000	100	3.5	9	2.5	12.6	8-lead SOIC, 8-lead MSOP	EAR99
AD8055	1	300	1400	400	3000	6	6.5	8	12	8-lead PDIP, 8-lead SOIC, 5-lead SOT-23	EAR99
AD8056	2	300	1400	400	3000	6	6	8	12	8-lead PDIP, 8-lead SOIC, 8-lead MSOP	EAR99
LT1398	2	300	800		10,000	4.5	4.6	3	12.6	16-lead SOIC	EAR99
LT1399	3	300	800		1500	4.5	4.6	3	12.6	16-lead SOIC, 16-lead SSOP	EAR99
LT1399HV	3	300	800		1500	4.5	4.6	3	15.5	16-lead SOIC, 16-lead SSOP	EAR99
LT6559	3	300	500		1500	4.5	3.9	4	12	16-lead QFN	EAR99
AD8005	1	270	1500	5000	5000	4	0.4	8	12	8-lead SOIC, 5-lead SOT-23	EAR99
ADA4859-3	3	265	740	0.7	9000	17	5.7	3	5.5	16-lead LFCSP	EAR99
LT1815	1	220	1500	2000	200	6	6.5	4	12.6	8-lead SOIC, 5-lead SOT-23, 6-lead SOT-23	EAR99
LT1816	2	220	1500	2000	200	6	6.5	2.5	12.6	8-lead SOIC, 8-lead MSOP, 10-lead MSOP, 8-lead DFN	EAR99
LT1817	4	220	1500	2000	200	6	6.5	2.5	12.6	14-lead SOIC, 16-lead SSOP	EAR99
AD8067	1	200	640	0.001	200	6.6	7	5	24	5-lead SOT-23	EAR99
ADA4855-3	3	200	870	3800	1300	6.8	7.8	3	5.5	16-lead LFCSP	EAR99
LT1468-2	1	200	30	3	30	5	3.9	10	36	8-lead SOIC, 8-lead DFN	EAR99
LT1469-2	2	200	30	3	50	5	4.1	10	36	8-lead SOIC, 12-lead DFN	EAR99
LT1722	1	200	70	40	100	3.8	3.7	4.6	12.6	8-lead SOIC, 5-lead SOT-23	EAR99
LT1723	2	200	70	40	100	3.8	3.7	4.6	12.6	8-lead SOIC, 8-lead MSOP	EAR99
LT1724	4	200	70	40	100	3.8	3.7	4.6	12.6	14-lead SOIC	EAR99
LT1739	2	200	600	100	1000	8	10	8	27	20-lead TSSOP-EP, 12-lead DFN	EAR99
LT1794	2	200	600	100	1000	8	10	8	36	20-lead SOIC, 20-lead TSSOP-EP	EAR99
LT6210	1	200	700		1000	6.5	5.8	3	13.2	6-lead SOT-23	EAR99
LT6211	2	200	700		1000	6.5	5.8	3	13.2	10-lead MSOP, 10-lead DFN	EAR99
LT6300	2	200	600	100	1000	8	10	8	27	16-lead SSOP	EAR99
LT6301	4	200	600	100	1000	8	4	8	27	28-lead TSSOP-EP	EAR99
AD8027	1	190	100	4000	240	4.3	6.5	2.7	12	8-lead SOIC, 6-lead SOT-23	EAR99
AD8028	2	190	100	4000	240	4.3	6.5	2.7	12	Chips or die, 8-lead SOIC, 10-lead MSOP	EAR99
LT1189	1	180	220	500	1000	30	13	4	18	8-lead PDIP, 8-lead SOIC	EAR99
LTC6246	1	180	90	30	50	4.2	0.95	2.5	5.25	6-lead SOT-23	EAR99
LTC6247	2	180	90	30	50	4.2	0.95	2.5	5.25	8-lead SOT-23, 8-lead MSOP, 10-lead MSOP, 8-lead DFN	EAR99
LTC6248	4	180	90	30	50	4.2	0.95	2.5	5.25	16-lead MSOP	EAR99
AD848	1	175	300	3300	500	5	4.8	9	36	8-lead PDIP, 8-lead CerDIP, 8-lead SOIC, chips or die	EAR99
ADA4350	1	175	100	0.00025	15	5	8.5	3.3	12	28-lead TSSOP	EAR99
AD8041	1	160	170	1200	2000	16	5.8	3	12	8-lead PDIP, 8-lead CerDIP, 8-lead SOIC	EAR99
LT1809	1	160	300	1800	600	16	12.5	2.5	12.6	8-lead SOIC, 6-lead SOT-23	EAR99
LT1810	2	160	300	1800	600	16	12.5	2.3	12.6	8-lead SOIC, 8-lead MSOP	EAR99
LT1203	1	150	300	600	10,000		10	9	36	8-lead PDIP, 8-lead SOIC	EAR99
LT1205	2	150	300	600	10,000		10	9	36	16-lead SOIC	EAR99
LT1221	1	150	250	100	500	6	8	5	36	8-lead PDIP, 8-lead SOIC	EAR99
LT1225	1	150	400	4000	500	7.5	7	5	36	8-lead PDIP, 8-lead SOIC	EAR99

Operational Amplifiers (Op Amps)

High Speed (BW ≥50 MHz) Amplifiers (Continued)

Part Number	Number of Amps	GBP (typ) (MHz)	Slew Rate (typ) (V/μs)	I _{BIAS} (typ) (nA)	V _{OS} (typ) (μV)	V _{NOISE} Density (typ) (nV/√Hz)	I _O /Amp (typ) (mA)	V _s Span (min) (V)	V _s Span (max) (V)	Package	ECCN Code
AD8065	1	145	180	0.003	400	7	7.4	5	24	Chips or die, 8-lead SOIC, 5-lead SOT-23	EAR99
AD8066	2	145	180	0.003	400	7	7.4	5	24	8-lead SOIC, 8-lead MSOP	EAR99
AD8013	3	140	1000	3000	2000	3.5	3.5	4.2	13	14-lead SOIC, chips or die	EAR99
AD8037	1	140	1500	3000	2000	4.5	18.5	6	12	8-lead SOIC, chips or die	EAR99
AD9632	1	130	1500	2000	2000	4.3	16	6	12	8-lead SOIC	EAR99
LT1259	2	130	1600		2000	3.6	5	4	36	14-lead PDIP, 14-lead SOIC	EAR99
LT1260	3	130	1600		2000	3.6	5	4	36	16-lead PDIP, 16-lead SOIC	EAR99
AD8048	1	120	1000	1000	1000	3.8	5.9	6	12	8-lead SOIC	EAR99
AD8036	1	110	1200	4000	2000	6.7	20.5	6	12	8-lead PDIP, 8-lead CerDIP, 8-lead SOIC, chips or die	EAR99
AD8047	1	110	750	1000	1000	5.2	5.8	6	12	8-lead PDIP, 8-lead SOIC	EAR99
AD9631	1	110	1300	2000	3000	7	17	6	12	8-lead PDIP, 8-lead SOIC, chips or die	EAR99
LT6550	3	110	340	15,000	15,000	12	9.5	3	12.6	10-lead MSOP	EAR99
LT6551	4	110	340	15,000	15,000	12	9.5	3	12.6	10-lead MSOP	EAR99
ADA4891-1	1	105	170	0.002	2500	9	4.4	2.7	5.5	8-lead SOIC, 5-lead SOT-23	EAR99
ADA4891-2	2	105	170	0.002	2500	9	4.4	2.7	5.5	8-lead SOIC, 8-lead MSOP	EAR99
ADA4891-3	3	105	170	0.002	2500	9	4.4	2.7	5.5	14-lead SOIC, 14-lead TSSOP	EAR99
ADA4891-4	4	105	170	0.002	2500	9	4.4	2.7	5.5	14-lead SOIC, 14-lead TSSOP	EAR99
AD8038	1	100	425	400	800	8	1	3	12	5-lead SC70, 8-lead SOIC	EAR99
AD8039	2	100	425	400	800	8	1	3	12	8-lead SOIC, 8-lead SOT-23	EAR99
AD8057	1	100	1150	500	1000	7	7.5	3	12	8-lead SOIC, 5-lead SOT-23, chips or die	EAR99
AD8058	2	100	1150	500	1000	7	7.5	3	12	8-lead SOIC, 8-lead MSOP, chips or die	EAR99
AD818	1	100	500	3300	500	10	7	5	36	8-lead PDIP, 8-lead SOIC	EAR99
AD828	2	100	450	3300	500	10	7.5	5	36	8-lead PDIP, 8-lead SOIC	EAR99
LT1223	1	100	1000		1000	33	6	5	36	8-lead PDIP, 8-lead SOIC	EAR99
LT1228	1	100	500	400	500	20	9	4	36	8-lead PDIP, 8-lead SOIC	EAR99
LT1812	1	100	750	900	400	8	3	2.5	12.6	8-lead SOIC, 5-lead SOT-23, 6-lead SOT-23	EAR99
LT1813	2	100	750	900	500	8	3	2.5	12.6	8-lead SOIC, 8-lead MSOP, 8-lead DFN	EAR99
LT1813HV	2	100	750	900	500	8	3	2.5	13.5	8-lead SOIC, 8-lead MSOP, 8-lead DFN	EAR99
LT1814	4	100	750	900	500	8	3	2.5	12.5	14-lead SOIC, 16-lead SSOP	EAR99
LT6205	1	100	600	18,000	1300	9	4	3	12.6	5-lead SOT-23	EAR99
LT6206	2	100	600	18,000	1300	9	4	3	12.6	8-lead MSOP	EAR99
LT6207	4	100	600	18,000	1300	9	4	3	12.6	16-lead SSOP	EAR99
LT1204	1	95	1000		5000	7	19	9	36	16-lead PDIP, 16-lead SOIC	EAR99
AD8042	2	90	225	1200	3000	15	6	3	12	8-lead SOIC, chips or die	EAR99
AD8044	4	90	190	2000	1400	16	2.875	3	12	14-lead PDIP, 14-lead SOIC	EAR99
AD8054	4	90	145	2000	1800	16	3.4	3	12	14-lead SOIC, 14-lead TSSOP	EAR99
AD8061	1	90	650	3500	1000	8.5	9.5	2.7	8	8-lead SOIC, 5-lead SOT-23	EAR99
AD8062	2	90	650	3500	1000	8.5	9.5	2.7	8	8-lead SOIC, 8-lead MSOP	EAR99
AD8063	1	90	650	3500	1000	8.5	9.5	2.7	8	8-lead SOIC, 6-lead SOT-23	EAR99
LT1191	1	90	450	500	1000	25	32	4	18	8-lead PDIP, 8-lead SOIC	EAR99
LT1468	1	90	22	3	30	5	3.6	6	36	8-lead PDIP, 8-lead SOIC, 8-lead DFN	EAR99
LT1469	2	90	22	3	50	5	4.1	6	36	8-lead PDIP, 8-lead SOIC, 12-lead DFN	EAR99
LT1805	4	85	100	125	350	21	2.7	2.3	12.6	14-lead SOIC	EAR99
LT1803	1	83	100	125	350	21	2.7	2.3	12.6	8-lead SOIC, 5-lead SOT-23	EAR99
LT1804	2	83	100	125	350	21	2.7	2.3	12.6	8-lead SOIC, 8-lead DFN	EAR99
AD8051	1	80	170	1400	1800	16	4.8	3	12	8-lead SOIC, 5-lead SOT-23	EAR99
AD8052	2	80	170	1400	1800	16	4.8	3	12	8-lead SOIC, 8-lead MSOP	EAR99
LT1193	1	80	500	500	2000	50	35	4	18	8-lead PDIP, 8-lead SOIC	EAR99
LT1800	1	80	25	25	75	8.5	1.6	2.3	12.6	8-lead SOIC, 5-lead SOT-23	EAR99
LT1801	2	80	25	25	75	8.5	1.6	2.3	12.6	8-lead SOIC, 8-lead MSOP, 8-lead DFN	EAR99
LT1802	4	80	25	25	75	8.5	1.6	2.3	12.6	14-lead SOIC	EAR99
LT6552	1	75	600	20,000	5000	55	12.5	3	12.6	8-lead SOIC, 8-lead DFN	EAR99
ADA4850-1	1	70	160	2300	600	10	2.5	2.7	6	8-lead LFCSOP	EAR99
ADA4850-2	2	70	160	2300	600	10	2.5	2.7	6	16-lead LFCSOP	EAR99
ADA4851-1	1	70	190	2200	600	10	2.9	2.7	12	6-lead SOT-23	EAR99
ADA4851-2	2	70	190	2200	600	10	2.9	2.7	12	8-lead MSOP	EAR99

Operational Amplifiers (Op Amps)

High Speed (BW ≥50 MHz) Amplifiers (Continued)

Part Number	Number of Amps	GBP (typ) (MHz)	Slew Rate (typ) (V/μs)	I _{BIAS} (typ) (nA)	V _{OS} (typ) (μV)	V _{NOISE} Density (typ) (nV/√Hz)	I _O /Amp (typ) (mA)	V _S Span (min) (V)	V _S Span (max) (V)	Package	ECCN Code
ADA4851-4	4	70	190	2200	600	10	2.9	2.7	12	14-lead TSSOP	EAR99
LT1363	1	70	1000	600	500	9	6.3	3	36	8-lead PDIP, 8-lead SOIC	EAR99
LT1364	2	70	1000	300	500	9	6	3	36	8-lead PDIP, 8-lead SOIC	EAR99
LT1365	4	70	1000	600	500	9	6	3	36	14-lead PDIP, 16-lead SOIC	EAR99
LT1206	1	66	900		3000	3.6	20	10	36	Round header/metal CAN, 7-lead DD PAK, 8-lead PDIP, 8-lead SOIC	EAR99
LT1207	2	66	900		3000	3.6	20	10	36	16-lead SOIC	EAR99
LT1795	2	65	900		3000	3.6	29	10	36	20-lead SOIC, 20-lead TSSOP-EP	EAR99
LT6220	1	60	20	15	70	10	0.9	2.2	12.6	8-lead SOIC, 5-lead SOT-23	EAR99
LT6221	2	60	20	15	70	10	0.9	2.2	12.6	8-lead SOIC, 8-lead DFN	EAR99
LT6222	4	60	20	15	70	10	0.9	2.2	12.6	16-lead SSOP	EAR99
ADA4853-1	1	55	120	1000	1000	22	1.4	2.65	5	6-lead SC70	EAR99
ADA4853-2	2	55	120	1000	1000	22	1.4	2.65	5	16-lead LFCSP	EAR99
ADA4853-3	3	55	120	1000	1000	22	1.4	2.65	5	16-lead LFCSP, 14-lead TSSOP	EAR99
AD8031	1	50	35	450	500	15	0.9	2.7	12	8-lead PDIP, 8-lead SOIC, 5-lead SOT-23	EAR99
AD8032	2	50	35	450	500	15	0.9	2.7	12	8-lead PDIP, 8-lead SOIC, 8-lead MSOP, chips or die	EAR99
AD8091	1	50	170	1400	1800	16	5.5	3	12	8-lead SOIC, 5-lead SOT-23	EAR99
AD8092	2	50	170	1400	1800	16	4.8	3	12	8-lead SOIC, 8-lead MSOP	EAR99
AD817	1	50	350	3300	500	15	7	5	36	8-lead PDIP, 8-lead SOIC	EAR99
AD826	2	50	350	3300	500	15	6.6	5	36	8-lead PDIP, 8-lead SOIC	EAR99
AD827	2	50	300	3300	300	15	10.5	9	36	8-lead PDIP, 8-lead CerDIP, 16-lead SOIC—wide, chips or die, LCC:cer leadless chip carr	EAR99
AD847	1	50	300	3300	500	15	4.8	9	36	8-lead PDIP, 8-lead CerDIP, 8-lead SOIC, chips or die	EAR99
AD8651	1	50	41	0.001	100	4.5	9	2.7	5.5	8-lead SOIC, 8-lead MSOP	EAR99
AD8652	2	50	41	0.001	100	4.5	9	2.7	5.5	8-lead SOIC, 8-lead MSOP	EAR99
LT1187	1	50	165	500	2000	65	13	4	18	8-lead PDIP, 8-lead SOIC	EAR99
LT1190	1	50	450	500	3000	50	32	4	18	8-lead PDIP, 8-lead SOIC	EAR99
LT1195	1	50	165	500	3000	70	12	4	18	8-lead PDIP, 8-lead SOIC	EAR99
LT1360	1	50	800	300	300	9	3.8	3	36	8-lead PDIP, 8-lead SOIC	EAR99
LT1361	2	50	800	300	300	9	3.8	5	36	8-lead PDIP, 8-lead SOIC	EAR99
LT1362	4	50	800	300	300	9	3.8	5	36	14-lead PDIP, 16-lead SOIC	EAR99
LTC6244	2	50	35	0.001	40	8	6.25	2.8	6	8-lead MSOP, 8-lead DFN	EAR99
LTC6244HV	2	50	35	0.001	40	8	6.25	2.8	12	8-lead MSOP, 8-lead DFN	EAR99
AD8014	1	400	4600	5000	2000	3.5	1.15	4.5	12	8-lead SOIC, 5-lead SOT-23	EAR99
AD8018	2	130	300	1000	1000	4.5	9	3.3	8	8-lead SOIC, 14-lead TSSOP	EAR99
AD812	2	145	250	300	2000	3.5	4.5	2.4	36	8-lead PDIP, 8-lead SOIC	EAR99
AD813	3		450	5000	2000	3.5	4.5	2.4	36	14-lead PDIP, 14-lead SOIC, chips or die, LCC:cer leadless chip carr	EAR99
ADA4312-1	1	195	2100					12	12	16-lead LFCSP	EAR99
ADA4856-3	3	225	800	3800	1300	14	7.8	3	5.5	16-lead LFCSP	EAR99
ADA4860-1	1	800	790	1500	3500	4	6	5	12	6-lead SOT-23	EAR99
ADA4862-3	3	300	830	600	2000	10.6	16	5	12	14-lead SOIC	EAR99

High Speed (BW ≥50 MHz), Low Noise Amplifiers

Part Number	Number of Amps	GBP (typ) (MHz)	Slew Rate (typ) (V/μs)	I _{BIAS} (typ) (nA)	V _{OS} (typ) (μV)	V _{NOISE} Density (typ) (nV/√Hz)	I _O /Amp (typ) (mA)	V _S Span (min) (V)	V _S Span (max) (V)	Package	ECCN Code
LT6274 <i>New</i>	1	40	2200	100	150	10	1.6	9	32	5-lead SOT-23	EAR99
AD8099	1	3800	470	6000	100	0.95	15	5	12	8-lead LFCSP, 8-lead SOIC-EP	EAR99
LTC6253-7	2	2000	500	100	50	2.75	3.3	2.5	5.25	10-lead MSOP	EAR99
AD8003	3	1650	3800	7000	700	1.8	9.5	4.5	10	24-lead LFCSP, chips or die	EAR99
ADA4895-1	1	1500	943	11,000	28	1	3	3	10	8-lead SOIC, 6-lead SOT-23	EAR99
ADA4895-2	2	1500	943	11,000	28	1	3	3	10	10-lead MSOP	EAR99
LT6200-10	1	1450	340	10,000	100	0.95	20	2.5	12.6	8-lead SOIC, 6-lead SOT-23	EAR99
LT6230-10	1	1450	250	5000	100	1.1	3.3	3	12.6	6-lead SOT-23	EAR99

Operational Amplifiers (Op Amps)

High Speed (BW ≥50 MHz), Low Noise Amplifiers (Continued)

Part Number	Number of Amps	GBP (typ) (MHz)	Slew Rate (typ) (V/μs)	I _{BIAS} (typ) (nA)	V _{os} (typ) (μV)	V _{NOISE} Density (typ) (nV/√Hz)	I _v /Amp (typ) (mA)	V _s Span (min) (V)	V _s Span (max) (V)	Package	ECCN Code
AD8021	1	1000	130	8000	400	2.1	7.8	4.5	24	8-lead SOIC, 8-lead MSOP	EAR99
LTC6360	1	1000	135	17,000	30	2.3	13.6	4.75	5.25	8-lead MSOP-EP, 8-lead DFN	EAR99
LT1226	1	1000	400	4000	300	2.6	7	5	36	8-lead PDIP, 8-lead SOIC	EAR99
LT1993-4	1	900	1100		1000	2.15	100	4	5.5	16-lead QFN	EAR99
AD8001	1	880	1200	5000	2000	2	5	6	12	8-lead PDIP, 8-lead CerDIP, 8-lead SOIC, 5-lead SOT-23, chips or die	EAR99
LT1993-2	1	800	1100		1000	3.5	100	4	5.5	16-lead QFN	EAR99
LT6200-5	1	750	210	10,000	100	0.95	20	2.5	12.6	8-lead SOIC, 6-lead SOT-23	EAR99
AD829	1	750	230	3300	100	1.7	5.3	9	36	20-lead LCC, 8-lead PDIP, 8-lead CerDIP, 8-lead SOIC, chips or die	EAR99
ADA4861-3	3	730	680	2900	100	3.2	16.1	5	12	14-lead SOIC	EAR99
LTC6252	1	720	280	100	50	2.75	3.3	2.5	5.25	6-lead SOT-23	EAR99
LTC6253	2	720	280	100	50	2.75	3.3	2.5	5.25	8-lead SOT-23, 8-lead MSOP, 10-lead MSOP, 8-lead DFN	EAR99
LTC6254	4	720	280	100	50	2.75	3.3	2.5	5.25	16-lead MSOP	EAR99
LT1993-10	1	700	1100		1000	1.7	100	4	5.5	16-lead QFN	EAR99
AD8002	2	600	1200	5000	2000	2	10	6	12	8-lead SOIC, 8-lead MSOP	EAR99
LT1222	1	500	200	100	100	3	8	5	36	8-lead PDIP, 8-lead SOIC	EAR99
AD8045	1	400	1350	2000	500	3	16	3.3	12	8-lead LFCSP, 8-lead SOIC-EP	EAR99
AD8008	2	380	1000	4000	500	2.7	9	5	12	8-lead SOIC, 8-lead MSOP	EAR99
LT6233-10	1	375	80	1500	100	1.9	1.15	3	12.6	6-lead SOT-23	EAR99
LT1806	1	325	125	1000	100	3.5	9	2.5	12.6	8-lead SOIC, 6-lead SOT-23	EAR99
LT1807	2	325	125	1000	100	3.5	9	2.5	12.6	8-lead SOIC, 8-lead MSOP	EAR99
ADA4899-1	1	280	310	100	35	1	14.7	4.5	12	8-lead LFCSP, 8-lead SOIC-EP	EAR99
AD8079	2	260	800	3000	5000	2	10	6	12	8-lead SOIC	EAR99
AD8004	4	250	3000	40000	1000	1.5	14	4	12	14-lead SOIC	EAR99
LT1252	1	250	250		5000	3	8.5	4	28	8-lead PDIP, 8-lead SOIC	EAR99
LT1253	2	250	250		5000	3	6	4	28	8-lead PDIP, 8-lead SOIC	EAR99
LT1254	4	250	250		5000	3	6	4	28	14-lead PDIP, 14-lead SOIC	EAR99
LT6230	1	215	70	5000	100	1.1	3.3	3	12.6	6-lead SOT-23	EAR99
LT6231	2	215	70	5000	50	1.1	3.3	3	12.6	8-lead SOIC, 8-lead DFN	EAR99
LT6232	4	215	70	5000	50	1.1	3.3	3	12.6	16-lead SSOP	EAR99
LT6236	1	215	60	5000	100	1.1	3.15	3	12.6	6-lead SOT-23	EAR99
LT6237	2	215	60	5000	100	1.1	3.15	3	12.6	8-lead MSOP, 8-lead DFN	EAR99
LT6238	4	215	60	5000	100	1.1	3.15	3	12.6	16-lead SSOP	EAR99
AD8024	4	200	390	1000	2000	3	17	5	24	16-lead SOIC	EAR99
ADA4807-1	1	200	225	1200	20	3.3	1	2.7	11	6-lead SC70, 6-lead SOT-23	EAR99
ADA4807-2	2	200	225	1200	20	3.3	1	2.7	11	10-lead LFCSP, 8-lead MSOP	EAR99
ADA4807-4	4	200	225	1200	20	3.3	1	2.7	11	14-lead TSSOP	EAR99
LT6200	1	165	44	10,000	100	0.95	20	2.5	12.6	8-lead SOIC, 6-lead SOT-23	EAR99
LT6201	2	165	50	10,000	100	0.95	20	2.5	12.6	8-lead SOIC, 8-lead DFN	EAR99
LT1227	1	140	1100		3000	3.2	10	4	36	8-lead PDIP, 8-lead SOIC	EAR99
AD8013	3	140	1000	3000	2000	3.5	3.5	4.2	13	14-lead SOIC, chips or die	EAR99
LT6202	1	100	25	1300	100	1.9	2.8	2.5	12.6	8-lead SOIC, 5-lead SOT-23	EAR99
LT6203	2	100	25	1300	100	1.9	2.8	2.5	12.6	8-lead SOIC, 8-lead MSOP, 8-lead DFN	EAR99
LT6204	4	100	25	1300	100	1.9	2.8	2.5	12.6	14-lead SOIC, 16-lead SSOP	EAR99
AD8022	2	100	50	2500	1500	2.5	4	4.5	26	8-lead SOIC, 8-lead MSOP	EAR99
AD8072	2	100	500	4000	2000	3	3	5	12	8-lead PDIP, 8-lead SOIC, 8-lead MSOP	EAR99
AD8073	3	100	500	4000	2000	3	3	5	12	14-lead SOIC	EAR99
LT1227MJ8	1	100	1100		3000	3.2	10	4	36	8-lead PDIP, 8-lead SOIC	EAR99
LT1229	2	100	700		3000	3.2	6	4	36	8-lead PDIP, 8-lead SOIC	EAR99
LT1230	4	100	700		3000	3.2	6	4	36	14-lead PDIP, 14-lead SOIC	EAR99
ADA4896-2	2	90	120	11,000	28	1	3	3	10	8-lead LFCSP, 8-lead MSOP	EAR99
ADA4897-1	1	90	120	11,000	28	1	3	3	10	8-lead SOIC, 6-lead SOT-23	EAR99
ADA4897-2	2	90	120	11,000	28	1	3	3	10	Chips or die, 10-lead MSOP	EAR99
LT6203X	2	83	24	1300	100	2	3.3	2.5	12.6	8-lead SOIC	EAR99
AD810	1	80	1000	2000	1500	2.9	6.8	5	36	8-lead PDIP, 8-lead CerDIP, 8-lead SOIC, chips or die	EAR99
LT1028	1	75	15	25	10	0.85	7.4	8	44	8-lead PDIP, 8-lead SOIC, 16-lead SOIC	EAR99

Operational Amplifiers (Op Amps)

High Speed (BW \geq 50 MHz), Low Noise Amplifiers (Continued)

Part Number	Number of Amps	GBP (typ) (MHz)	Slew Rate (typ) (V/ μ s)	I _{BIAS} (typ) (nA)	V _{os} (typ) (μ V)	V _{NOISE} Density (typ) (nV/ \sqrt Hz)	I _{O/Amp} (typ) (mA)	V _s Span (min) (V)	V _s Span (max) (V)	Package	ECCN Code
LT1115	1	70	15	50	50	0.9	8.5	8	44	8-lead PDIP, 16-lead SOIC	EAR99
LT1994	1	70	65	18,000	2000	3	13.3	2.375	12.6	8-lead MSOP, 8-lead DFN	EAR99
LT1210	1	66	900		3000	3	35	8	36	7-lead TO-220 (flow 06), round header/metal CAN, 7-lead DD PAK, 7-lead TO-220 (flow 44), 7-lead TO-220 (flow 37), 16-lead SOIC	EAR99
LT1210X	1	66	900	2000	3000	3	35	10	30	16-lead TSSOP-EP	EAR99
LT1126	2	65	11	7	20	2.7	2.6	8	44	8-lead PDIP, 8-lead SOIC	EAR99
LT1127	4	65	11	7	25	2.7	2.6	8	44	14-lead PDIP, 16-lead SOIC	EAR99
LT6233	1	60	15	1500	100	1.9	1.15	3	12.6	6-lead SOT-23	EAR99
LT6234	2	60	17	1500	500	1.9	1.15	3	12.6	8-lead SOIC, 8-lead DFN	EAR99
LT6235	4	60	17	1500	50	1.9	1.15	3	12.6	16-lead SSOP	EAR99
LT1037	1	60	15	10	10	2.5	2.6	8	44	8-lead PDIP, 8-lead SOIC	EAR99
LT1497	2	59	900		3000	3	6	4	36	16-lead SOIC, 8-lead SOIC	EAR99
ADA4898-1	1	50	55	100	20	0.9	8.1	9	36	8-lead SOIC-EP	EAR99
ADA4898-2	2	50	55	100	20	0.9	7.9	9	36	8-lead SOIC-EP	EAR99
ADA4800	1	400	415	1000	30,000	1.5	1.4	4	17	6-lead LFCSP, chips or die	EAR99
AD8000	1	1500	4100	3000	1000	1.6	13.5	4.5	12	8-lead LFCSP, 8-lead SOIC-EP	EAR99
AD815	2	120	900	2000	10,000	1.85	15	10	36		EAR99
AD8009	1	1000	5500	50,000	2000	1.9	14	5	12	8-lead SOIC, 5-lead SOT-23, chips or die	EAR99
AD8017	2	160	1600	16000	1800	1.9	7	4.4	12	8-lead SOIC	EAR99
AD811	1	140	400	2000	500	1.9	14.5	9	36	20-lead LCC, 8-lead PDIP, 8-lead CerDIP, 8-lead SOIC, 16-lead SOIC—wide, LCC:cer leadless chip carr, chips or die	EAR99
AD8010	1	230	800	10,000	5000	2	15.5	9	12	8-lead PDIP, 8-lead SOIC, 16-lead SOIC—wide	EAR99
AD8011	1	300	1100	5000	2000	2	1	3	12	8-lead PDIP, 8-lead SOIC	EAR99
AD8023	3	250	1200	15,000	2000	2	6.2	4.2	15	14-lead SOIC, chips or die	EAR99
AD844	1	60	2000	150	50	2	6.5	9	36	8-lead PDIP, 8-lead CerDIP 16-lead SOIC—wide, chips or die	EAR99
ADA4870	1	70	2500	9000	1000	2.1	32.5	10	40	PSOP_3 430 mil with heatsink, chips or die	EAR99
ADA4311-1	2	310	1050	4500	1000	2.4	11.8	12	12	10-lead MSOP_ED	EAR99
AD8012	2	350	2250	3000	1500	2.5	1.7	3	12	8-lead SOIC, 8-lead MSOP	EAR99
AD8016	2	78	1000	4000	1000	2.6	12.5	6	26	28-lead TSSOP-EP	EAR99
AD8007	1	650	1000	400	500	2.7	9	5	12	5-lead SC70, 8-lead SOIC	EAR99
ADA4310-1	2	190	820	6000	1000	2.85	7.6	5	12	16-lead LFCSP, 10-lead MSOP_ED	EAR99
AD8014	1	400	4600	5000	2000	3.5	1.15	4.5	12	8-lead SOIC, 5-lead SOT-23	EAR99
AD812	2	145	250	300	2000	3.5	4.5	2.4	36	8-lead PDIP, 8-lead SOIC	EAR99
AD813	3	125	450	5000	2000	3.5	4.5	2.4	36	14-lead PDIP, 14-lead SOIC, chips or die, LCC:cer leadless chip carr	EAR99

High Output Current (I_{OUT} \geq 100 mA) Amplifiers

Part Number	Number of Amps	I _{out} (typ) (A)	Slew Rate (typ) (V/ μ s)	V _{os} (max) (mV)	I _{BIAS} (max) (nA)	V _{NOISE} Density (typ) (nV/ \sqrt Hz)	GBP (typ) (MHz)	I _{O/Amp} (typ) (mA)	V _s Span (min) (V)	V _s Span (max) (V)	Architecture	Package	ECCN Code
LT1739	2	1.2	600	5	4000	8	200	10	8	27	Voltage feedback	20-lead TSSOP-EP, 12-lead DFN	EAR99
LT6300	2	1.2	600	5	4000	8	200	10	8	27	Voltage feedback	16-lead SSOP	EAR99
LT6301	4	1.2	600	5	4000	8	200	4	8	27	Voltage feedback	28-lead TSSOP-EP	EAR99
ADA4870	1	1	2500	10	23000	2.1		32.5	10	40	Current feedback	PSOP_3 with heatsink, chips or die	EAR99
LT1795	2	1	900	13		3.6	65	29	10	36	Current feedback	20-lead SOIC, 20-lead TSSOP-EP	EAR99
LT1886	2	0.8	200	4	4000	6	700	7	4	13.2	Voltage feedback	8-lead SOIC	EAR99
LT1969	2	0.8	200	4	4000	6	700	7	4	13.2	Voltage feedback	10-lead MSOP	EAR99
LT1970	1	0.8	1.6	0.6	600	15	3.6	7	5	36	Voltage feedback	20-lead TSSOP-EP	EAR99
LT1970A	1	0.8	1.6	0.6		15	3.6	7	5	36	Voltage feedback	20-lead TSSOP-EP	EAR99
LT1794	2	0.72	600	5	4000	8	200	10	8	36	Voltage feedback	20-lead SOIC, 20-lead TSSOP-EP	EAR99

Operational Amplifiers (Op Amps)

High Output Current ($I_{OUT} \geq 100$ mA) Amplifiers (Continued)

Part Number	Number of Amps	I_{OUT} (typ) (A)	Slew Rate (typ) (V/ μ s)	V_{OS} (max) (mV)	I_{BIAS} (max) (nA)	V_{NOISE} Density (typ) (nV/ \sqrt{Hz})	GBP (typ) (MHz)	I_O /Amp (typ) (mA)	V_S Span (min) (V)	V_S Span (max) (V)	Architecture	Package	ECCN Code
AD8016	2	0.6	1000	3	75,000	2.6		12.5	6	26	Current feedback	28-lead TSSOP-EP (EP = 3.5 mm)	EAR99
AD815	2	0.5	900	8	5000	1.85		15	10	36	Current feedback		EAR99
AD8392A		0.5	515	4	10,000	2.5		5.8	10	24	xDSL line driver	32-lead LFCSP-EP, 28-lead TSSOP-EP	EAR99
LT1206	1	0.5	900	10		3.6	66	20	10	36	Current feedback	Round header/ metal CAN, 7-lead DD PAK, 8-lead PDIP, 8-lead SOIC	EAR99
LT1207	2	0.5	900	10		3.6	66	20	10	36	Current feedback	16-lead SOIC	EAR99
AD8018	2	0.4	300	15	8000	4.5		9	3.3	8	Current feedback	8-lead SOIC, 14-lead TSSOP	EAR99
LT1010	1	0.375	200	150	25,000	20	30	5	4.5	44	Buffer	5-lead TO-220 (flow 06), 5-lead TO-220, 8-lead PDIP, 8-lead DFN	EAR99
AD8397	2	0.31	53	3	900	4.5	35	11	3	25.2	Bipolar voltage feedback	8-lead SOIC, 8-lead SOIC-EP (2.41 mm exposed pad)	EAR99
AD8509	9	0.3	7	20	50			0.944	3.3	6.5	Buffer voltage feedback		EAR99
AD8017	2	0.27	1600	3	45,000	1.9		7	4.4	12	Bipolar current feedback	8-lead SOIC	EAR99
AD8531	1	0.25	5	25	0.05	30	3	1.25	3	6	CMOS voltage feedback	5-lead SC70, 8-lead SOIC, 5-lead SOT-23	EAR99
AD8532	2	0.25	5	25	0.05	30	3	1.25	3	6	CMOS voltage feedback	8-lead SOIC, 8-lead MSOP, 8-lead TSSOP	EAR99
AD8534	4	0.25	5	25	0.05	30	3	1.25	3	6	CMOS voltage feedback	14-lead SOIC, 14-lead TSSOP	EAR99
AD8591	1	0.25	5	25	0.05	30	3	1.25	2.5	6	CMOS voltage feedback	6-lead SOT-23	EAR99
AD8592	2	0.25	5	25	0.05	30	3	1.25	2.5	6	CMOS voltage feedback	10-lead MSOP	EAR99
ADA4312-1	1	0.225	2100	1.2	175,000				12	12	xDSL line driver	16-lead LFCSP	EAR99
AD8655	1	0.22	11	0.25	0.01	2.7	28	4.5	2.7	5.5	CMOS voltage feedback	8-lead SOIC, 8-lead MSOP	EAR99
AD8656	2	0.22	11	0.25	0.01	2.7	28	4.5	2.7	5.5	CMOS voltage feedback	8-lead SOIC, 8-lead MSOP	EAR99
LT1497	2	0.22	900	15		3	59	6	4	36	Current feedback	16-lead SOIC, 8-lead SOIC	EAR99
AD8010	1	0.2	800	12	135,000	2		15.5	9	12	Current feedback	8-lead PDIP, 8-lead SOIC, 16-lead SOIC—wide	EAR99
AD8009	1	0.175	5500	5	15,000	1.9		14	5	12	Current feedback	8-lead SOIC, 5-lead SOT-23, chips or die	EAR99
AD8615	1	0.15	12	0.1	0.001	7	24	1.7	2.7	5.5	CMOS voltage feedback	5-lead TSOT	EAR99
AD8616	2	0.15	12	0.06	0.001	7	24	1.7	2.7	5.5	CMOS voltage feedback	8-lead SOIC, 8-lead MSOP	EAR99
AD8618	4	0.15	12	0.06	0.001	7	24	2	2.7	5.5	CMOS voltage feedback	14-lead SOIC, 14-lead TSSOP	EAR99
AD8012	2	0.125	2250	4	12,000	2.5		1.7	3	12	Current feedback	8-lead SOIC, 8-lead MSOP	EAR99
ADA4891-1	1	0.125	170	10	0.05	9	105	4.4	2.7	5.5	CMOS video amplifier voltage feedback	8-lead SOIC, 5-lead SOT-23	EAR99
ADA4891-2	2	0.125	170	10	0.05	9	105	4.4	2.7	5.5	CMOS video amplifier voltage feedback	8-lead SOIC, 8-lead MSOP	EAR99
ADA4891-3	3	0.125	170	10	0.05	9	105	4.4	2.7	5.5	CMOS video amplifier voltage feedback	14-lead SOIC, 14-lead TSSOP	EAR99
ADA4891-4	4	0.125	170	10	0.05	9	105	4.4	2.7	5.5	CMOS video amplifier voltage feedback	14-lead SOIC, 14-lead TSSOP	EAR99
LT6411	2	0.105	3300	10		8	650	16	4.5	12.6	Voltage feedback	16-lead QFN	EAR99
LT6553	3	0.105	2500	10	50,000	9	650	8	4	13.2	Fixed gain video amplifier	16-lead SSOP	EAR99

Operational Amplifiers (Op Amps)

High Output Current ($I_{OUT} \geq 100 \text{ mA}$) Amplifiers (Continued)

Part Number	Number of Amps	I_{out} (typ) (A)	Slew Rate (typ) (V/ μ s)	V_{os} (max) (mV)	I_{BIAS} (max) (nA)	V_{NOISE} Density (typ) (nV/ $\sqrt{\text{Hz}}$)	GBP (typ) (MHz)	I_c /Amp (typ) (mA)	V_s Span (min) (V)	V_s Span (max) (V)	Architecture	Package	ECCN Code
LT6554	3	0.105	2500	35	50,000	20	650	8	4	13.2	Fixed gain video amplifier	16-lead SSOP	EAR99
LT6555	3	0.105	2200	16		9	650	9	4.5	12.6	Fixed gain video amplifier	24-lead SSOP, 24-lead QFN	EAR99
LT6556	3	0.105	2100	67		11	750	9.5	4.5	12.6	Fixed gain video amplifier	24-lead SSOP, 24-lead QFN	EAR99
AD8000	1	0.1	4100	10	45,000	1.6		13.5	4.5	12	Bipolar current feedback	8-lead LFCSP, 8-lead SOIC-EP	EAR99
AD8003	3	0.1	3800	9.3	50,000	1.8	1650	9.5	4.5	10	Current feedback	24-lead LFCSP, chips or die	EAR99
AD811	1	0.1	400	3	5000	1.9		14.5	9	36	Current feedback	20-lead LCC, 8-lead PDIP, 8-lead CerDIP, 8-lead SOIC, 16-lead SOIC—wide, LCC:cer leadless chip carr, chips or die	EAR99
LT1217	1	0.1	500	3		6.5	10	1	10	36	Current feedback	8-lead PDIP, 8-lead SOIC	EAR99
LT1395	1	0.1	800	12		4.5	400	4.6	3	12.6	Current feedback	8-lead SOIC, 5-lead SOT-23, 6-lead SOT-23	EAR99
LT1396	2	0.1	800	12		4.5	400	4.6	3	12.6	Current feedback	8-lead SOIC, 8-lead MSOP, 8-lead DFN	EAR99
LT1397	4	0.1	800	12		4.5	400	4.6	3	12.6	Current feedback	14-lead SOIC, 16-lead SSOP, 14-lead DFN	EAR99
LT1398	2	0.1	800	12		4.5	300	4.6	3	12.6	Current feedback	16-lead SOIC	EAR99
LT1399	3	0.1	800	12		4.5	300	4.6	3	12.6	Current feedback	16-lead SOIC, 16-lead SSOP	EAR99
LT1399HV	3	0.1	800	12		4.5	300	4.6	3	15.5	Current feedback	16-lead SOIC, 16-lead SSOP	EAR99
LT6557	3	0.1	2200	40		12	500	22.5	3	7.5	Fixed gain video amplifier	16-lead SSOP, 16-lead DFN	EAR99

ADC Drivers/Differential Amplifiers

LTC6363: Precision, Low Power, Fully Differential Amplifier/ADC Driver

Key Features

- ▶ Available with user set gain or fixed gain of 0.5 V/V, 1 V/V, or 2 V/V
- ▶ 2.9 nV/ $\sqrt{\text{Hz}}$ input-referred noise
- ▶ 45 ppm max gain error
- ▶ 0.5 ppm/ $^{\circ}\text{C}$ max gain error drift
- ▶ 94 dB minimum CMRR
- ▶ 100 μV maximum offset voltage
- ▶ 2 mA maximum supply current
- ▶ Fast settling: 720 ns to 18-bit, 8 V p-p output

Key Benefits

- ▶ Simple and accurate 18-bit and 20-bit SAR ADC driving solution
- ▶ Amplifier and ultraprecision resistors in compact MSOP package achieve a level of precision and compactness that is difficult and expensive to achieve discretely
- ▶ Available in fixed gains of 0.5 V/V, 1 V/V, or 2 V/V, which provides flexibility when scaling inputs to the full range of ADCs

Applications

- ▶ 20-bit, 18-bit, and 16-bit SAR ADC drivers
- ▶ Single-ended to differential conversion
- ▶ Low power ADC drivers
- ▶ Level shifter
- ▶ Differential line drivers
- ▶ Battery-powered instrumentation

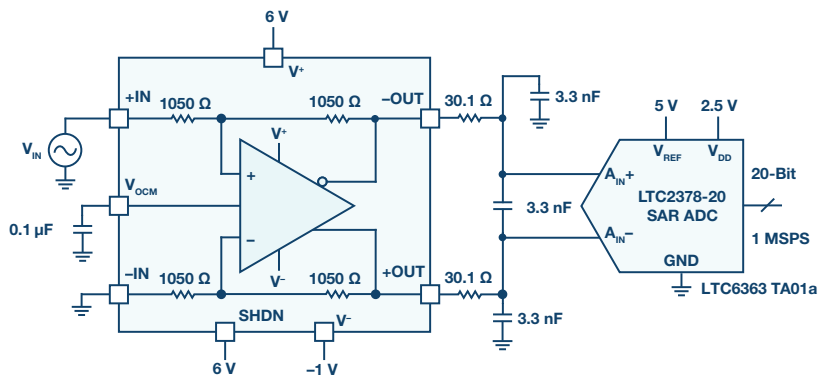

ADC Drivers/Differential Amplifiers

New

ADA4945-1: Dual Power Mode, 0.1 mV/°C Drift, Fully Differential Precision ADC Driver

Key Features

- ▶ Wide supply voltage range from 3 V to 12 V with negative rail input and rail-to-rail output
- ▶ Flexible dual power operating modes:
 - ▶ 4 mA full power mode (200 MHz)
 - ▶ 1.4 mA low power mode (80 MHz)
- ▶ THD and noise performance in full power mode
- ▶ Low total harmonic distortion (THD)
 - ▶ -120 dB at 1 kHz
 - ▶ -110 dB at 100 kHz
- ▶ Low input voltage noise
 - ▶ 1.6 nV $\sqrt{\text{Hz}}$ at 100 kHz
- ▶ Low dc errors:
 - ▶ Input offset voltage drift
 - ▶ 0.1 $\mu\text{V}/^\circ\text{C}$ typical, 0.5 $\mu\text{V}/^\circ\text{C}$ max (20°C to 85°C)
 - ▶ Input offset current drift
 - ▶ 0.1 nA/°C typical, 2 nA/°C max (20°C to 85°C)
- ▶ Adjustable output voltage clamps for ADC input protection

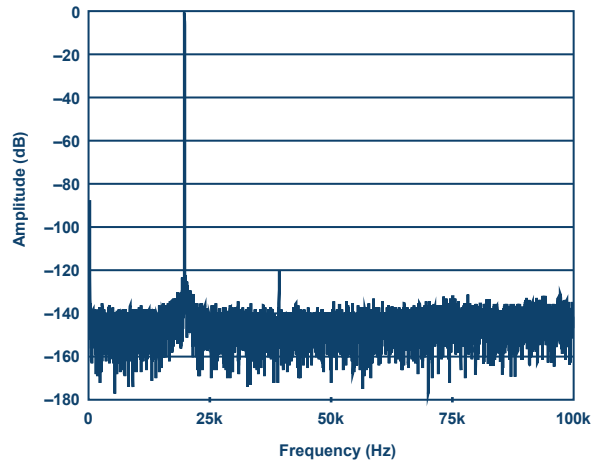
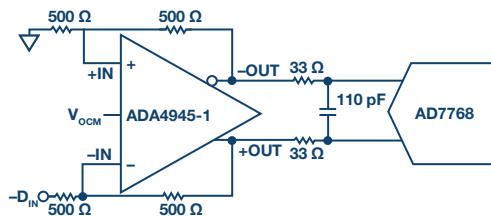

ADC Drivers/Differential Amplifiers

ADC Drivers/Differential Amplifiers

Part Number	Number of Channels	BW –3 dB (typ) (MHz)	Gain Set	Gain (min) (dB)	Gain (max) (dB)	V _{NOISE} Density (typ) (nV/√Hz)	Distortion 2 nd Harmonic (typ) (dBc)	Distortion 3 rd Harmonic (typ) (dBc)	I _s (typ) (mA)	V _s Span (min) (V)	V _s Span (max) (V)	Input type	Package	ECCN Code
ADA4945-1 <i>New</i>	1	200	Resistor			6.2	–140	–148	4	2.7	11	Differential	16-lead LFCSP (1.6 mm EP)	EAR99
ADL5569 <i>New</i>	2	6500	Pin strap	6	20	1	–78	–71	86	4.75	5.25	Differential	16-lead LFCSP	EAR99
ADL5565	1	6000	Pin strap	0	15.5	1.5	–108	–103	80	2.8	5.2	Differential	16-lead LFCSP	EAR99
ADA4960-1	1	5000	Analog	0	18	4.8	–73	–72	60	4.75	5.25	Differential	16-lead LFCSP	EAR99
ADL5566	2	4500	Pin strap	3	16	1.3	–94.7	–100	160	2.8	5.2	Differential, single-ended	24-lead LFCSP	EAR99
ADL5567	2	4300	Pin strap	0	20	1.29	–94	–103	148	3.15	5.25	Differential	24-lead LFCSP (2.1 mm EP)	EAR99
ADL5562	1	3300	Pin strap	3	15.5	2.1	–104	–87	80	3	3.6	Differential	16-lead LFCSP	EAR99
ADA4961	1	3200	Digital pin strap	–6	15		–84	–100	150	3.3	5.5	Differential	24-lead LFCSP (2.5 mm EP)	EAR99
ADL5561	1	2900	Pin strap	3	15.5	2.1	–95	–87	40	3	3.6	Differential	16-lead LFCSP	EAR99
LTC6400-14	1	2400	Fixed	14	14	2.5	–107	–96	85	2.85	3.5	Differential	16-lead QFN	EAR99
ADA4927-1	1	2300	Resistor			1.4	–87	–89	22.1	4.5	11	Differential	16-lead LFCSP	EAR99
ADA4927-2	2	2300	Resistor			1.4	–87	–89	44.2	4.5	11	Differential	24-lead LFCSP (2.5 mm EP)	EAR99
AD8351	1	2200	Analog	0	26	2.7	–79	–81	28	3	5.5	Differential	16-lead LFCSP, 10-lead MSOP, LFCSP:LEADFRM chip scale	EAR99
AD8352	1	2200	Analog	3	25	2.7	–83	–82	37	3	5.5	Differential	16-lead LFCSP	EAR99
LTC6400-8	1	2200	Fixed	8	8	1	–118	–98	85	2.85	3.5	Differential	16-lead QFN	EAR99
LTC6401-8	1	2200	Fixed	8	8	1	–109	–118	45	2.85	3.5	Differential	16-lead QFN	EAR99
LTC6401-14	1	2000	Fixed	14	14	1.1			45	2.85	3.5	Differential	16-lead QFN	EAR99
LTC6409	1	2000	Resistor	0		1.1	–104	–106	52	2.7	5.25	Differential	10-lead QFN	EAR99
LTC6416	1	2000	Fixed	0	0	1.8			42	2.7	3.9	Differential	10-lead QFN	EAR99
LTC6430A-15	1	2000	Fixed	15.2	15.2	1			160	4.75	5.25	Differential	24-lead QFN	EAR99
LTC6430A-20	1	2000	Fixed	20.8	20.8	0.6			170	4.75	5.25	Differential	24-lead QFN	EAR99
LTC6430B-15	1	2000	Fixed	15.2	15.2	1			160	4.75	5.25	Differential	24-lead QFN	EAR99
LTC6430B-20	1	2000	Fixed	20.8	20.8	0.6			170	4.75	5.25	Differential	24-lead QFN	EAR99
ADA4937-1	1	1900	Resistor			2.2	–70	–84	39.5	3	5.25	Differential	16-lead LFCSP	EAR99
ADA4937-2	2	1900	Resistor			2.2	–77	–84	80	3	5.25	Differential	24-lead LFCSP	EAR99
LTC6400-26	1	1900	Fixed	26	26	1.5			85	2.85	3.5	Differential	16-lead QFN	EAR99
LTC6400-20	1	1800	Fixed	20	20	2.1	–97	–93	90	2.85	3.5	Differential	16-lead QFN	EAR99
LTC6420-20	2	1800	Fixed	20	20	2.2	–80	–80	80	2.85	3.5	Differential	20-lead QFN	EAR99
LTC6401-26	1	1600	Fixed	26	26	1.5			45	2.85	3.5	Differential	16-lead QFN	EAR99
LTC6417	1	1600	Fixed	0	0	1.5	–100	–69	123	4.75	5.25	Differential	20-lead QFN	EAR99
ADA4930-1	1	1400	Resistor			1.2	–104	–101	35	3.3	5	Differential	16-lead LFCSP	EAR99
ADA4930-2	2	1400	Resistor			1.2	–104	–101	70	3.3	5	Differential	24-lead LFCSP	EAR99
ADA4939-1	1	1400	Resistor			2.3	–77	–95	37.7	3	5.25	Differential	16-lead LFCSP	EAR99
ADA4939-2	2	1400	Resistor			2.3	–77	–91	75.4	3	5.25	Differential	24-lead LFCSP	EAR99
LTC6410-6	1	1400	Fixed	6	6		–85	–71	104	2.8	5.5	Differential	16-lead QFN	EAR99
LTC6419	2	1400	Resistor	0		1.1	–82	–106	52	2.7	5.25	Differential	20-lead LQFN	EAR99
LTC6432A-15	1	1400	Fixed	15.2	15.2	0.8	–85	–61	166	4.75	5.25	Differential	24-lead QFN	EAR99
LTC6432B-15	1	1400	Fixed	15.2	15.2	0.8	–85	–61	166	4.75	5.25	Differential	24-lead QFN	EAR99
LTC6401-20	1	1300	Fixed	20	20	0.91	–88	–91	50	2.85	3.5	Differential	16-lead QFN	EAR99
LTC6421-20	2	1300	Fixed	20	20	2.2			40	2.85	3.5	Differential	20-lead QFN	EAR99
ADL5205	2	1200	Digital	–9	26	1.2	–90	–94	175	3.15	5.25	Differential	40-lead LFCSP	EAR99
ADA4938-1	1	1000	Resistor			2.6	–82	–82	40	4.5	11	Differential	16-lead LFCSP	EAR99
ADA4938-2	2	1000	Resistor			2.6	–82	–82	80	4.5	11	Differential	24-lead LFCSP	EAR99
AD8350	1	900	Analog fixed	20	20	1.7	–66	–65	30	5	10	Differential	8-lead SOIC, 8-lead MSOP	EAR99
LT1993-4	1	900	Fixed	12	4	2.15	–100	–102	100	4	5.5	Differential	16-lead QFN	EAR99
AD8368	1	800	Analog	–12	22				60	4.75	5.5	Single-ended	24-lead LFCSP-EP	EAR99
LT1993-2	1	800	Fixed	6	6	3.5	–94	–94	100	4	5.5	Differential	16-lead QFN	EAR99
LTC6405	1	800	Resistor	0		1.6			18	4.5	5.25	Differential	8-lead MSOP-EP, 16-lead QFN	EAR99
LTC6406	1	800	Resistor	0		1.6	–80	–69	18	2.7	3.5	Differential	8-lead MSOP-EP, 16-lead QFN	EAR99

ADC Drivers/Differential Amplifiers

ADC Drivers/Differential Amplifiers (Continued)

Part Number	Number of Channels	BW –3 dB (typ) (MHz)	Gain Set	Gain (min) (dB)	Gain (max) (dB)	V_{NOISE} Density (typ) (nV/√Hz)	Distortion 2 nd Harmonic (typ) (dBc)	Distortion 3 rd Harmonic (typ) (dBc)	I_s (typ) (mA)	V_s Span (min) (V)	V_s Span (max) (V)	Input type	Package	ECCN Code
LTC6412	1	800	Analog	–14	17	2.7	–80	–80	110	3	3.6	Differential	24-lead QFN	EAR99
AD8370	1	750	Digital	–11	34	2.1	–65	–62	79	3	5.5	Differential	16-lead TSSOP-EP (3.0 mm pad size)	EAR99
ADA4950-1	1	750	Digital pin strap	0	9.54	9.2	–107	–105	9.5	3	11	Differential	16-lead LFCSP	EAR99
ADA4950-2	2	750	Digital pin strap	0	9.54	9.2	–107	–105	19	3	11	Differential	24-lead LFCSP	EAR99
AD8376	2	700	Digital	–4	20		–82	–91	250	4.5	5.5	Differential	32-lead LFCSP-EP	EAR99
LT1993-10	1	700	Fixed	20	20	1.9	–100	–102	100	4	5.5	Differential	16-lead QFN	EAR99
LT6411	2	650	Pin strap	0	6	8	–88	–88	16	4.5	12.6	Differential	16-lead QFN	EAR99
AD8375	1	630	Digital	–4	20		–85	–92	125	4.5	5.5	Differential	24-lead LFCSP	EAR99
AD8366	2	600	Digital	4.5	20.25		–88	–92	180	4.75	5.25	Differential	32-lead LFCSP	EAR99
AD8369	1	600	Digital	–10	40	2	–68	–64	37	3	5.5	Differential	16-lead TSSOP	EAR99
LTC6404-1	1	600	Resistor	0		1.5			27.2	2.7	5.5	Differential	16-lead QFN	EAR99
LTC6404-2	1	600	Resistor	6		1.5			29.7	2.7	5.5	Differential	16-lead QFN	EAR99
ADA4932-1	1	560	Resistor			3.6	–110	–130	9.6	3	11	Differential	16-lead LFCSP	EAR99
ADA4932-2	2	560	Resistor			3.6	–110	–130	19.2	3	11	Differential	24-lead LFCSP	EAR99
LTC6404-4	1	530	Resistor	12		1.5			30	2.7	5.5	Differential	16-lead QFN	EAR99
AD8367	1	500	Analog	–2.5	42.5	1.84			26	2.7	5.5	Single-ended	14-lead TSSOP	EAR99
AD8139	1	410	Resistor			2.25	–90	–105	24.5	4.5	12	Differential	8-lead LFCSP, 8-lead SOIC-EP	EAR99
AD8131	1	400	Fixed	6	6	12.5	–95	–101	11.5	2.8	11	Differential single-ended	8-lead SOIC, 8-lead MSOP	EAR99
AD8132	1	350	Resistor			8	–83	–98	12	2.7	11	Differential	8-lead SOIC, 8-lead MSOP	EAR99
AD8138	1	320	Resistor			5	–94	–114	20	3	11	Differential	8-lead SOIC, 8-lead MSOP, chips or die	EAR99
LT6402-12	1	300	Fixed	12	12	2.7	–85	–84	30	4	5.5	Differential	16-lead QFN	EAR99
LT6402-20	1	300	Fixed	20	20	1.85	–96	–96	30	4	5.5	Differential	16-lead QFN	EAR99
LT6402-6	1	300	Fixed	6	6	3.8			30	4	5.5	Differential	16-lead QFN	EAR99
ADA4940-1	1	260	Resistor			3.9	–102	–96	1.25	3	7	Differential	16-lead LFCSP, 8-lead SOIC	EAR99
ADA4940-2	2	260	Resistor			3.9	–102	–96	1.25	3	7	Differential	24-lead LFCSP-EP	EAR99
LTC6360	1	250	Resistor			2.3				4.75	5.25		8-lead MSOP-EP, 8-lead DFN	EAR99
LTC6403-1	1	200	Resistor	0		2.8	–97	–95	10.8	2.7	5.25	Differential	16-lead QFN	EAR99
AD8475	1	150	Digital pin strap	–8	–2	10	–110	–108	3	3	10	Differential	16-lead LFCSP, 10-lead MSOP	EAR99
AD8372	2	130	Digital	–9	32		–78	–85	212	4.5	5.5	Differential	32-lead LFCSP-EP	EAR99
AD8137	1	76	Resistor			8.25	–100	–105	3.2	2.7	12	Differential	8-lead LFCSP, 8-lead SOIC	EAR99
LT1994	1	70	Resistor	0		3	–99	–96	13.3	2.375	12.6	Differential	8-lead MSOP, 8-lead DFN	EAR99
LTC6363-0.5	1	60	Fixed	–6.02	–6.02	2.9	–113	–118	1.7	2.8	11	Differential	8-lead MSOP, 8-lead DFN	EAR99
ADA4922-1	1	38	Fixed	6	6	12	–116	–109	9.4	5	26	Single-ended	8-lead LFCSP, 8-lead SOIC-EP	EAR99
LTC6363	1	35	Resistor	–20		2.9	–113	–118	1.7	2.8	11	Differential	8-lead MSOP, 8-lead DFN	EAR99
LTC6363-1	1	35	Fixed	0	0	2.9	–113	–118	1.7	2.8	11	Differential	8-lead MSOP, 8-lead DFN	EAR99
LTC6362	1	34	Resistor	0		3.9	–120	–116	0.9	2.8	5.25	Differential	8-lead MSOP, 8-lead DFN	EAR99
LT6350	1	33	Resistor			1.9	–102	–107	4.8	2.7	12	Single-ended	8-lead MSOP, 8-lead DFN	EAR99
ADA4941-1	1	31	Analog			5.1	–75	–71	2.3	2.7	12	Single-ended	8-lead LFCSP, 8-lead SOIC	EAR99
LTC6363-2	1	21	Fixed	6.02	6.02	2.9	–113	–118	1.7	2.8	11	Differential	8-lead MSOP, 8-lead DFN	EAR99
LT6600-20	1	20	Resistor	0		15	–83	–88	46	2.7	11	Differential	8-lead SOIC	EAR99
LT6600-15	1	15	Resistor	0		19	–88	–88	46	2.7	11	Differential	8-lead SOIC	EAR99
LT6604-15	2	15	Resistor	0			–86	–90	35	3	11	Differential	32-lead QFN	EAR99

ADC Drivers/Differential Amplifiers

ADC Drivers/Differential Amplifiers (Continued)

Part Number	Number of Channels	BW -3 dB (typ) (MHz)	Gain Set	Gain (min) (dB)	Gain (max) (dB)	V _{NOISE} Density (typ) (nV/√Hz)	Distortion 2 nd Harmonic (typ) (dBc)	Distortion 3 rd Harmonic (typ) (dBc)	I _s (typ) (mA)	V _s Span (min) (V)	V _s Span (max) (V)	Input type	Package	ECCN Code
LT6600-10	1	10	Resistor	0		14	-97	-88	39	2.7	11	Differential	8-lead SOIC, 12-lead DFN	EAR99
LT6604-10	2	10	Resistor	0			-88	-97	35	3	11	Differential	32-lead QFN	EAR99
AD8476	1	6	Fixed	1	1	39	-120	-130	0.33	3	18	Differential	16-lead LFCSP, 8-lead MSOP	EAR99
LT1567		5	Analog			1.4			11	2.7	12	Single-ended	8-lead MSOP	EAR99
LT6600-5	1	5	Resistor	0		16			28	2.7	11	Differential	8-lead SOIC	EAR99
LT6604-5	2	5	Resistor	0			-92	-88	26	3	11	Differential	32-lead QFN	EAR99
LTC1992-10	1	4	Resistor	20	20	45			650	2.7	12	Differential	8-lead MSOP	EAR99
LTC1992-2	1	4	Resistor	6	6	45			650	2.7	12	Differential	8-lead MSOP	EAR99
LTC1992-5	1	4	Resistor	14	14	45			650	2.7	12	Differential	8-lead MSOP	EAR99
LTC1992	1	3.2	Resistor	0		35			650	2.7	12	Differential	8-lead MSOP	EAR99
LTC1992-1	1	3	Resistor	0		45			650	2.7	12	Differential	8-lead MSOP	EAR99
LT6600-2.5	1	2.5	Resistor	0		23	-95	-88	26	2.7	11	Differential	8-lead SOIC, 12-lead DFN	EAR99
LT6604-2.5	2	2.5	Resistor	0			-92	-88	26	3	11	Differential	32-lead QFN	EAR99
AD8138S			Resistor										Cer flatpack with leads	EAR99

Instrumentation Amplifiers

Instrumentation Amplifiers

Part Number	Number of Amps	Gain Set	Gain (min) (V/V)	Gain (max) (V/V)	V_{os} (max) (μ V)	V_{os} TC (max) (μ V/ $^{\circ}$ C)	CMRR—High Gain (min) (dB)	I_{BIAS} (max) (nA)	I_{q}/Amp (max) (mA)	BW—Low Gain (typ) (MHz)	V_s Span (min) (V)	V_s Span (max) (V)	Package	ECCN Code
LTC2053	1	Resistor	1		10	0.05	120	10	1.3	0.2	2.7	11	8-lead MSOP, 8-lead DFN-EP	EAR99
LTC6915	1	Digital	1	4096	10	0.05	125	10	1.6	0.2	2.7	11	16-lead SSOP (150 mil), 12-lead DFN-EP	EAR99
LTC1100	1	Fixed gain	10	100	10	0.1	104	0.05	2.8	1.8	4	18	8-lead PDIP (300 mil), 16-lead SOIC (300 mil)	EAR99
AD8230	1	Resistor	2	1000	10	0.05	110	1	4	0.002	8	16	8-lead SOIC	EAR99
AD8556	1	Digital	70	1280	12	0.065	94	54	2.7	0.28	5	5.5	16-lead LFCSOP-EP, 8-lead SOIC	EAR99
AD8557	1	Digital	28	1300	12	0.065	96	25		0.6	2.7	5.5	16-lead LFCSOP-EP, 8-lead SOIC	EAR99
AD8231	1	Digital	1	128	15	0.05	110	0.5	5	2.7	3	6	16-lead LFCSOP-EP	EAR99
AD8422	1	Resistor	1	1000	25	0.3	150	0.5	0.3	2.2	3.6	36	8-lead SOIC, 8-lead MSOP	EAR99
AD8221	1	Resistor	1	1000	25	0.3	140	0.4	1	0.825	4.6	36	8-lead SOIC, 8-lead MSOP, chips or die	EAR99
AD8421	1	Resistor	1	1000	25	0.2	140	1	2.3	10	5	36	8-lead SOIC, 8-lead MSOP	EAR99
AD624	1	Pin strap	1	1000	25	0.25	130	50	5	1	12	36	16-lead side-brazed CerDip, chips or die	EAR99
AD625	1	Resistor	1	10,000	25	0.25	120	15	5	0.65	12	36	16-lead side-brazed CerDip, 16-lead PDIP, LCC: cer leadless chip carr	EAR99
AD8428	1	Fixed gain	2000	2000	25	0.3	140	50	6.8	3.5	8	36	8-lead SOIC	EAR99
LT1168	1	Resistor	1	10,000	40	0.3	126	0.25	0.53	0.4	4.6	40	8-lead PDIP (300 mil), 8-lead SOIC (150 mil)	EAR99
LT1167	1	Resistor	1	10,000	40	0.3	126	0.35	1.3	1	4.6	40	8-lead PDIP (300 mil), 8-lead SOIC (150 mil)	EAR99
LT1167-1	1	Resistor	1	10,000	40	0.3	126	0.35	1.3	1	4.6	40	8-lead PDIP (300 mil), 8-lead SOIC (150 mil)	EAR99
AD8226	1	Resistor	1	1000	50	1	120	27	0.425	1.5	2.2	36	8-lead SOIC, 8-lead MSOP	EAR99
AD8228	1	Pin strap	10	100	50	0.8	120	0.6	1	0.65	4.6	36	8-lead SOIC, 8-lead MSOP	EAR99
AD620	1	Resistor	1	10,000	50	0.6	120	1	1.3	1	4.6	36	8-lead PDIP, 8-lead CerDip, 8-lead SOIC, chips or die	EAR99
AD8293G160	1	Fixed gain	160	160	50	0.3	94	2	1.3	0.5	1.8	5.5	8-lead SOT-23	EAR99
AD8293G80	1	Fixed gain	80	80	50	0.3	94	2	1.3	0.5	1.8	5.5	8-lead SOT-23	EAR99
AD524	1	Pin strap	1	1000	50	0.5	120	15	5	1	12	36	16-lead side-brazed CerDip, LCC: cer leadless chip carr, 16-lead SOIC—wide, chips or die	EAR99
AD8429	1	Resistor	1	10,000	50	0.3	140	150	7	15	8	36	8-lead SOIC	EAR99
AD8222	2	Resistor	1	10,000	60	0.3	140	1	1.1	1.2	4.6	36	16-lead LFCSOP-EP, 16-lead LFCSOP-EP	EAR99
AD8295	1	Resistor	1	1000	60	0.3	140	0.8	2.3	1.2	4.6	36	16-lead LFCSOP—no EP	EAR99
AD8237	1	Resistor	1	1000	75	0.3	114	0.65	0.13	0.2	1.8	5.5	8-lead MSOP	EAR99
AD8227	1	Resistor	5	1000	100	1	110	27	0.425	0.25	2.2	36	8-lead SOIC, 8-lead MSOP, N/A	EAR99
AD8426	2	Resistor	1	1000	100	1	110	30	0.425	1.5	2.2	36	16-lead LFCSOP—no EP	EAR99
AD8223	1	Resistor	5	1000	100	1	96	25	0.5	0.125	3	24	8-lead SOIC, 8-lead MSOP	EAR99
AD623	1	Resistor	1	1000	100	1	105	25	0.55	0.8	2.7	12	8-lead PDIP, 8-lead SOIC, 8-lead MSOP	EAR99
LTC6800	1	Resistor	1		100	0.25	120	10	1.2	0.2	2.7	5.5	8-lead MSOP, 8-lead DFN-EP	EAR99

Instrumentation Amplifiers

Instrumentation Amplifiers (Continued)

Part Number	Number of Amps	Gain Set	Gain (min) (V/V)	Gain (max) (V/V)	V_{os} (max) μ V	V_{os} TC (max) (μ V/ $^{\circ}$ C)	CMRR—High Gain (min) (dB)	I_{BIAS} (max) (nA)	I_o /Amp (max) (mA)	BW—Low Gain (typ) (MHz)	V_s Span (min) (V)	V_s Span (max) (V)	Package	ECCN Code
AMP01	1	Resistor	0.1	10,000	100	1	125	4	4.8	0.57	9	36	18-lead CerDip, 20-lead SOIC—wide, chips or die	EAR99
AMP02	1	Resistor	1	10,000	100	2	115	0.01	6	1.2	9	36	8-lead PDIP, 16-lead SOIC—wide	EAR99
AD8229	1	Resistor	1	1000	100	1	134	70	7	15	8	34	8-lead side-brazed CerDIP, 8-lead SOIC, chips or die	EAR99
AD627	1	Resistor	5	1000	125	1	83	10	0.085	0.08	2.2	36	8-lead PDIP, 8-lead SOIC	EAR99
AD8220	1	Resistor	1	1000	125	5	100	0.025	0.75	1.5	4.5	36	8-lead MSOP	EAR99
AD621	1	Pin strap	10	100	125	1.5	120	1	1.3	0.8	4.6	18	8-lead PDIP, 8-lead CerDip, 8-lead SOIC	EAR99
AD622	1	Resistor	1	1000	125	1	103	5	1.3	1	5.2	36	8-lead PDIP, 8-lead SOIC	EAR99
LT1920	1	Resistor	1	10,000	125	1	110	2	1.3	0.8	4.6	40	8-lead PDIP (300 mil), 8-lead SOIC (150 mil)	EAR99
AD8420	1	Resistor	1	1000	150	1	100	27	0.1	0.25	2.7	36	8-lead MSOP	EAR99
AD8225	1	Fixed gain	5	5	150	2	86	1.2	1.2	0.9	3.4	36	8-lead SOIC	EAR99
LT1101	1	Fixed gain	10	100	160	2	112	8	0.13	0.37	2.3	44	8-lead PDIP (300 mil), 16-lead SOIC (300 mil)	EAR99
AD8224	2	Resistor	1	1000	175	5	100	0.01	0.8	1.5	4.5	36	16-lead LFCS-EP, 16-lead LFCS-EP	EAR99
AD522	1	Resistor	1	1000	200	25	100		8	0.03	10	36	14-lead CerDip (bottom brazed)	EAR99
AD8553	1	Resistor	1	1000	375	3	120	1	1.2	0.001	1.8	5.5	10-lead MSOP	EAR99
AMP04	1	Resistor	1	1000	400	3	90	30	0.9	0.7	5	36	8-lead PDIP, 8-lead SOIC, chips or die	EAR99
LT1102	1	Fixed gain	10	100	600	8	98	0.04	5	35	18	40	8-lead PDIP (300 mil)	EAR99
LT1789-1	1	Resistor	1	1000	750	0.7	100	40	0.095	0.06	2.2	36	8-lead SOIC (150 mil)	EAR99
AD8250	1	Digital	1	10	800	6.2	98	30	4.5	10	10	30	10-lead MSOP	EAR99
AD8251	1	Digital	1	8	800	6.2	98	30	4.5	10	10	34	10-lead MSOP	EAR99
AD8253	1	Digital	1	1000	1050	6.2	100	50	5.3	10	10	30	10-lead MSOP	EAR99
AD8235	1	Resistor	5	200	2500	0.7	100	0.05	0.04	0.023	1.8	5.5	11-ball WLCS-EP	EAR99
LT1789-10	1	Resistor	10	1000	3000	0.7	98	40	0.095	0.06	2.2	36	8-lead SOIC (150 mil)	EAR99
AD8236	1	Resistor	5	200	3500	2.5	100	0.01	0.04	0.023	1.8	5.5	8-lead MSOP	EAR99
AD8290	1	Fixed gain	50	50	935,000	300	110	1	1.8	0.00025	2.6	5.5	16-lead LFCS-EP	EAR99
AD8232	1	Fixed gain	100	100	8000	10	80	0.2	0.23	0.002	2.7	3.3	20-lead LFCS-EP	EAR99
AD8233	1	Fixed gain	100	100	6000	2	80	0.2	0.07		1.7	3.3	20-ball WLCS	EAR99

Difference Amplifiers

Difference Amplifiers

Part Number	Number of Amps	Common-Mode In (min) (V)	Common-Mode In (max) (V)	Gain (min) (V/V)	Gain (max) (V/V)	BW—Low Gain (typ) (MHz)	Slew Rate (typ) (V/ μ s)	I_o /Amp (max) (mA)	V_s Span (min) (V)	V_s Span (max) (V)	Input Beyond Supply	Package	ECCN Code
LT1997-2 <i>New</i>	1	-255	255	0.1	0.25	1	0.75	0.4	3.3	50	Yes	16-lead MSOP (4 pins removed), 14-lead DFN	EAR99
LT1990-10 <i>New</i>	1	-250	250	10	10	0.1	0.4	0.18	2.4	36	No	8-lead SOIC (150 mil), 8-lead MSOP	EAR99
LT6376 <i>New</i>	1	-230	230	10	10	0.16	4.1	0.4	3.3	50	Yes	16-lead MSOP (4 pins removed), 14-lead DFN	EAR99
AD8479	1	-600	600	1	1	0.13	7.5	0.65	5	36	Yes	8-lead SOIC	EAR99
AD629	1	-270	270	1	1	0.5	2.1	1	5	36	Yes	8-lead PDIP, 8-lead SOIC, chips or die	EAR99
LT6375	1	-270	270	1	1	0.375	2.4	0.4	3.3	50	Yes	16-lead MSOP (4 pins removed), 14-lead DFN	EAR99
LT1990	1	-250	250	1	10	0.1	0.55	0.18	2.4	36	Yes	8-lead SOIC	EAR99
LT1997-3	1	-160	160	-13	14	1.1	0.75	0.4	3.3	50	Yes	16-lead MSOP (4 pins removed), 14-lead DFN	EAR99
AD628	1	-120	120	0.1	100	0.6	0.3	1.6	4.5	36	Yes	8-lead SOIC, 8-lead MSOP	EAR99
LT1996	1	-60	60	9	117	0.56	0.12	0.11	2.7	36	Yes	10-lead MSOP, 10-lead DFN	EAR99
AD8208	1	-2	45	20	20	0.07	1	3	4.5	5.5	Yes	8-lead SOIC, 8-lead MSOP	EAR99
AD8209	1	-2	45	14	14	0.08	1	3	4.5	5.5	Yes	8-lead MSOP	EAR99
AD8278	1	-45.3	40.5	0.5	2	1	1.4	0.2	2	36	Yes	8-lead SOIC, 8-lead MSOP	EAR99
AD8279	2	-45.3	40.5	0.5	2	1	1.3	0.35	2	36	Yes	14-lead SOIC	EAR99
AD8273	2	-40.5	40.5	0.5	3	20	20	2.5	5	36	Yes	14-lead SOIC	EAR99
AD8274	1	-40.5	40.5	0.5	2	20		2.6	5	36	Yes	8-lead SOIC, 8-lead MSOP	EAR99
AD8276	1	-30.2	27	1	1	0.55	1.1	0.2	2	36	Yes	8-lead SOIC, 8-lead MSOP	EAR99
AD8277	2	-30.2	27	1	1	0.55	1.1	0.2	2	36	Yes	14-lead SOIC	EAR99
AD626	1	-24	24	10	100	0.1	0.22	2	2.4	10	Yes	8-lead PDIP, 8-lead SOIC	EAR99
AMP03	1	-20	20	1	1	3	9.5	3.5	10	36	Yes	8-lead header, 8-lead PDIP, 8-lead SOIC	EAR99
LT1991	1	-18	18	1	13	0.56	0.12	0.11	2.4	40	Yes	10-lead MSOP, 10-lead DFN	EAR99
AD8270	2	-15.4	15.4	0.5	2	20	30	2.5	5	36	Slightly	16-lead LFCSP	EAR99
AD8271	1	-15.4	15.4	0.5	2	20	30	2.6	5	36	Slightly	10-lead MSOP	EAR99
LT1995	1	-15	15	1	7	32	1000	8.5	5	30	Slightly	10-lead MSOP, 10-lead DFN	EAR99
AD8275	1	-12.3	12	0.2	0.2	15	25	2.3	3.3	15	Yes	8-lead MSOP	EAR99
ADA4830-1	1	-10	9.5	0.5	0.5	84	300	10	2.9	5.5	Yes	8-lead LFCSP	EAR99
ADA4830-2	2	-10	9.5	0.5	0.5	84	300	10	2.9	5.5	Yes	16-lead LFCSP	EAR99

Current Sense Amplifiers

Current Sense Amplifiers

Part Number	Common-Mode In (min) (V)	Common-Mode In (max) (V)	V _{os} (max) (mV)	Gain (V/V)	BW -3 dB (typ) (MHz)	V _s Span (min) (V)	V _s Span (max) (V)	V _m Direction	Filter Option	Automotive	Package	ECCN Code
LTC6115 <i>New</i>	5	100	0.5	Resistor set	0.5	5	100	Unidirectional	No	Yes	12-lead MSOP	EAR99
AD8214			8	Comparator		5	65		No	No	8-lead MSOP	EAR99
LTC2946	0	100	0.077	Voltage to I ² C		2.7	100		No	No	16-lead MSOP, 16-lead DFN	EAR99
LTC6101HV	5	100	0.3	Resistor set	0.02	5	100	Unidirectional	No	No	5-lead SOT-23, 8-lead MSOP	EAR99
LTC6102HV	5	100	0.01	Resistor set	0.014	5	100	Unidirectional	No	No	8-lead MSOP, 8-lead DFN	EAR99
LT1999-10	-5	80	0.75	10	0.2	4.5	5.5	Bidirectional	No	No	8-lead SOIC, 8-lead MSOP	EAR99
LT1999-20	-5	80	0.75	20	0.2	4.5	5.5	Bidirectional	No	No	8-lead SOIC, 8-lead MSOP	EAR99
LT1999-50	-5	80	0.75	50	0.2	4.5	5.5	Bidirectional	No	No	8-lead SOIC, 8-lead MSOP	EAR99
LTC2945	0	80	0.05	Voltage to I ² C		2.7	80		No	No	12-lead MSOP, 12-lead QFN	EAR99
AD8219	4	80	0.3	60	0.5	4	80	Unidirectional	No	No	8-lead MSOP	EAR99
AD8218	4	80	0.075	20	0.45	4	80	Bidirectional	No	No	8-lead LFCSP, 8-lead MSOP	EAR99
AD8217	4.5	80	0.3	20	0.5	4.5	80	Unidirectional	No	No	8-lead MSOP	EAR99
LTC4151	7	80	0.1	Voltage to I ² C		7	80	Unidirectional	No	No	16-lead SOIC, 10-lead MSOP, 10-lead DFN	EAR99
AD8417	-2	70	0.4	60	0.25	2.7	5.5	Bidirectional		Yes	8-lead SOIC, 8-lead MSOP	EAR99
AD8418	-2	70	0.4	20	0.25	2.7	5.5	Bidirectional	No	Yes	8-lead SOIC, 8-lead MSOP	EAR99
AD8418A	-2	70	0.2	20	0.25	2.7	5.5	Bidirectional		Yes	8-lead SOIC, 8-lead MSOP	EAR99
AD8216	-4	65	3	3	3	4.5	5.5	Bidirectional	No	Yes	8-lead SOIC	EAR99
AD8207	-4	65	0.4	20	0.15	3.3	5.5	Bidirectional		Yes	8-lead SOIC	EAR99
AD8210	-2	65	1.8	20	0.5	4.5	5.5	Bidirectional	No	Yes	8-lead SOIC	EAR99
AD8211	-2	65	2.5	20	0.5	4.5	5.5	Unidirectional	No	Yes	5-lead SOT-23	EAR99
AD8213	-2	65	2.2	20	0.5	4.5	5.5	Unidirectional	Yes	Yes	10-lead MSOP	EAR99
AD8215	-2	65	2.5	20	0.45	4.5	5.5	Unidirectional	No	Yes	8-lead SOIC	EAR99
AD8206	-2	65	4.5	20	0.1	4.5	5.5	Bidirectional	No	Yes	8-lead SOIC	EAR99
AD8205	-2	65	4.5	50	0.05	4.5	5.5	Unidirectional	No	Yes	8-lead SOIC	EAR99
AD8212	7	65	3	Resistor set	1	7	65	Unidirectional	No	Yes	8-lead MSOP	EAR99
LT1787HV	2.5	60	0.075	8	0.012	2.5	60	Bidirectional	No	No	8-lead SOIC, 8-lead MSOP	EAR99
LT6108	2.7	60	0.35	Resistor set	0.1	2.7	60	Unidirectional	No	No	8-lead MSOP, 8-lead DFN	EAR99
LT6109	2.7	60	0.45	Resistor set	0.1	2.7	60	Unidirectional	No	No	10-lead MSOP	EAR99
LT6118	2.7	60	0.2	Resistor set	0.1	2.7	60	Unidirectional	No	No	8-lead MSOP, 8-lead DFN	EAR99
LT6119	2.7	60	0.2	Resistor set	0.1	2.7	60	Unidirectional	No	No	10-lead MSOP	EAR99
LTC6101	4	60	0.3	Resistor set	0.02	4	60	Unidirectional	No	No	5-lead SOT-23, 8-lead MSOP	EAR99
LTC6102	4	60	0.01	Resistor set	0.014	4	60	Unidirectional	No	No	8-lead MSOP, 8-lead DFN	EAR99
LTC6104	4	60	0.45	Resistor set	0.014	4	60	Bidirectional	No	No	8-lead MSOP	EAR99
LTC6103	4	60	0.45	Resistor set	0.012	4	60	Unidirectional	No	No	8-lead MSOP	EAR99
AD8209A	-2	50	4	14	0.1	4.5	5.5	Unidirectional	Yes	Yes	8-lead MSOP	EAR99
AD8208	-2	45	4	20	0.08	4.5	5.5	Unidirectional		Yes	8-lead SOIC, 8-lead MSOP	EAR99
AD8209	-2	45	4	14	0.08	4.5	5.5	Unidirectional		Yes	8-lead MSOP	EAR99
LT1787	2.5	36	0.075	8	0.012	2.5	36	Bidirectional	No	No	8-lead SOIC, 8-lead MSOP	EAR99
LT6106	2.7	36	0.25	Resistor set	0.02	2.7	36	Unidirectional	No	No	5-lead SOT-23	EAR99
LT6107	2.7	36	0.25	Resistor set	0.02	2.7	36	Unidirectional	No	No	5-lead SOT-23	EAR99
LT6100	2.7	36	0.3	10, 12.5, 20, 25, 40, 50	0.015	2.7	36	Unidirectional	No	No	8-lead MSOP, 8-lead DFN	EAR99
LT6105	2.85	36	0.3	Resistor set	0.01	2.85	36	Unidirectional	No	No	8-lead MSOP, 6-lead DFN	EAR99
RH6105	2.85	36	0.3	Resistor set	0.01	2.85	36	Unidirectional	No	No		EAR99
AD8203	-6	30	2	14	0.06	3.5	12	Unidirectional	Yes	No	8-lead MSOP	EAR99
AD8202	-6	28	2	20	0.05	3.5	12	Unidirectional	Yes	Yes	Chips or die, 8-lead SOIC, 8-lead MSOP	EAR99
ADM4073	2	28		20	1.8	3	28	Unidirectional	No	No	6-lead SOT-23	EAR99
AD626	-24	24		10 100		2.4	10		Yes	No	8-lead PDIP, 8-lead SOIC	EAR99
AD22057	1	24		20		3	36	Unidirectional	Yes	No	8-lead SOIC	EAR99
LTC4150	2.7	8.5	0.1	Voltage to frequency		2.7	8.5	Bidirectional	No	No	10-lead MSOP	EAR99
LTC2990	2.9	5.5		Voltage to I ² C		3	5.5		No	No	10-lead MSOP	EAR99
LTC2991	2.9	5.5		Voltage to I ² C		3	5.5		No	No	16-lead MSOP	EAR99

Filters

Filters

Part Number	Filters Per Package	Filter Type	Filter Order	Clock Tunable	Filter response	Fo Min (typ)	Fo Max (typ)	Package	ECCN Code
LTC6601-2	1	Low-pass differential	2	No	Pin configurable	5 MHz	25 MHz	20-lead QFN	EAR99
LTC6601-1	1	Low-pass differential	2	No	Pin configurable	5 MHz	25 MHz	20-lead QFN	EAR99
LTC6602	2	Band-pass differential	9	Yes	Elliptic	4 kHz	900 kHz	24-lead QFN	EAR99
LTC6603	2	Low-pass differential	9	Yes	Elliptic	20 kHz	2.5 MHz	24-lead QFN	EAR99
LTC6605-10	2	Low-pass differential	2	No	Pin configurable	10 MHz	14 MHz	22-lead DFN	EAR99
LTC6605-14	2	Low-pass differential	2	No	Pin configurable	14 MHz	20 MHz	22-lead DFN	EAR99
LTC6605-7	2	Low-pass differential	2	No	Pin configurable	6.5 MHz	10 MHz	22-lead DFN	EAR99
LT6604-10	2	Low-pass differential	4	No	Chebyshev		10 MHz	32-lead QFN	EAR99
LT6604-15	2	Low-pass differential	4	No	Chebyshev		15 MHz	32-lead QFN	EAR99
LT6604-2.5	2	Low-pass differential	4	No	Chebyshev		2.5 MHz	32-lead QFN	EAR99
LT6604-5	2	Low-pass differential	4	No	Chebyshev		5 MHz	32-lead QFN	EAR99
LT6600-15	1	Low-pass differential	4	No	Chebyshev		15 MHz	8-lead SOIC	EAR99
LT6600-5	1	Low-pass differential	4	No	Chebyshev		5 MHz	8-lead SOIC	EAR99
LT6600-2.5	1	Low-pass differential	4	No	Chebyshev		2.5 MHz	8-lead SOIC, 12-lead DFN	EAR99
LT6600-10	1	Low-pass differential	4	No	Chebyshev		10 MHz	8-lead SOIC, 12-lead DFN	EAR99
LT1568	Dual 2 nd order	Low-pass/band-pass	4	No	Resistor configurable	100 kHz	5 MHz	16-lead SSOP	EAR99
LT6600-20	1	Low-pass differential	4	No	Chebyshev		20 MHz	8-lead SOIC	EAR99
LTC1564	1	Low-pass	8	No	Programable elliptic	10 kHz	150 kHz	16-lead SSOP	EAR99
LTC1566-1	1	Low-pass	7	No	Elliptic		2.3 MHz	8-lead SOIC	EAR99
LTC1563-2	Dual 2 nd order	Low-pass/band-pass	4	No	Resistor configurable	256 Hz	256 kHz	16-lead SSOP	EAR99
LTC1563-3	Dual 2 nd order	Low-pass	4	No	Resistor configurable	256 Hz	256 kHz	16-lead SSOP	EAR99
LTC1565-31	1	Low-pass	7	No	Linear phase		650 kHz	8-lead SOIC	EAR99
LTC1569-6	1	Low-pass	10	Yes	Elliptic	20 Hz	64 kHz	8-lead SOIC	EAR99
LTC1569-7	1	Low-pass	10	Yes	Elliptic	30 Hz	256 kHz	8-lead SOIC	EAR99
LTC1562-2	Quad 2 nd order	Universal	8	No	Resistor configurable	50 kHz	300 kHz	20-lead SSOP	EAR99
LTC1562	Quad 2 nd order	Universal	8	No	Resistor configurable	10 kHz	150 kHz	16-lead PDIP, 20-lead SSOP	EAR99
LTC1067	Dual 2 nd order	Universal	4	Yes	Resistor configurable	10 Hz	16 kHz	16-lead SOIC, 16-lead SSOP	EAR99
LTC1067-50	Dual 2 nd order	Universal	4	Yes	Resistor configurable	20 Hz	30 kHz	16-lead SOIC, 16-lead SSOP	EAR99
LTC1069-6	1	Low-pass	8	Yes	Elliptic	20 Hz	15 kHz	8-lead SOIC	EAR99
LTC1560-1	1	Low-pass	5	No	Elliptic	500 kHz	1MHz	8-lead SOIC	EAR99
LTC1068	Quad 2 nd order	Universal	8	Yes	Resistor configurable	10 Hz	50 kHz	24-lead PDIP, 28-lead SSOP	EAR99
LTC1068-200	Quad 2 nd order	Universal	8	Yes	Resistor configurable	5 Hz	25 kHz	24-lead PDIP, 28-lead SSOP	EAR99
LTC1068-25	Quad 2 nd order	Universal	8	Yes	Resistor configurable	40 Hz	160 kHz	24-lead PDIP, 28-lead SSOP	EAR99
LTC1068-50	Quad 2 nd order	Universal	8	Yes	Resistor configurable	20 Hz	60 kHz	24-lead PDIP, 28-lead SSOP	EAR99
LTC1069-1	1	Low-pass	8	Yes	Elliptic	10 Hz	12 kHz	8-lead PDIP, 8-lead SOIC	EAR99
LTC1069-7	1	Low-pass	8	Yes	Bessel (linear phase)	40 Hz	200 kHz	8-lead SOIC	EAR99
LTC1066-1	1	Low-pass	8	Yes	Elliptic	20 Hz	100 kHz	18-lead SOIC	EAR99

Comparators

Comparators

Part Number	Number of Channels	Prop Delay V _{p-p} (typ) (ns p-p)	V _{os} (typ) (mV)	Output Logic	Adjustable Hysteresis	V _s Type	V _s Pos-1 (min) (V)	V _{SUPPLY} Pos-1 (max) (V)	I _s Pos (max) (mA)	Temperature Range	Package	ECCN Code
HMC874	1	0.085	5	PECL	Adjustable	Multi	3.135	3.465	9	-40°C to +85°C	16-lead LCC	EAR99
HMC674LC3C	1	0.085	5	PECL	Adjustable	Multi	3.135	3.465	9	-40°C to +85°C	16-lead LCC	EAR99
HMC674LP3E	1	0.085	5	PECL	Adjustable	Multi	3.135		9	-40°C to +85°C	16-lead LCC, 16-lead LFCSP	EAR99
HMC974	1	0.088	4	PECL		Multi	3.135	3.465	20	-40°C to +85°C	16-lead LCC	EAR99
HMC675LC3C	1	0.1	5	CML	Adjustable	Multi			9	-40°C to +85°C	16-lead LCC	EAR99
HMC675LP3E	1	0.1	5	CML	Adjustable	Multi			9	-40°C to +85°C	16-lead QFN	EAR99
ADCMP572	1	0.15	2	CML	Adjustable	Single	3.1	5.4	52	-40°C to +85°C	16-lead LFCSP	EAR99
ADCMP573	1	0.15	2	PECL	Adjustable	Single	3.1	5.4	80	-40°C to +85°C	16-lead LFCSP	EAR99
ADCMP580	1	0.18	4	CML	Adjustable	Dual	4.5	5.5	8	-40°C to +125°C	16-lead LFCSP	EAR99
ADCMP581	1	0.18	4	ECL	Adjustable	Dual	4.5	5.5	8	-40°C to +125°C	16-lead LFCSP	EAR99
ADCMP582	1	0.18	4	PECL	Adjustable	Dual	4.5	5.5	8	-40°C to +125°C	16-lead LFCSP	EAR99
ADCMP566	2	0.25	1.5	ECL	Adjustable	Dual	4.75	5.25	18	-40°C to +85°C	32-lead LFCSP	EAR99
ADCMP567	2	0.25	1	PECL	Adjustable	Dual	4.75	5.25	20	-40°C to +85°C	32-lead LFCSP	EAR99
ADCMP565	2	0.31	1.5	ECL	Adjustable				18	-40°C to +85°C	20-lead PLCC	EAR99
LTC6957-1	1	0.5		LVPECL		Single	3.15	3.45	22	-40°C to +85°C	12-lead MSOP, 12-lead DFN	EAR99
ADCMP551	2	0.5	2	PECL	Fixed	Single	3.135	5.25	17	-40°C to +85°C	16-lead QSOP	EAR99
ADCMP552	2	0.5	2	PECL	Adjustable	Single	3.135	5.25	17	-40°C to +85°C	20-lead QSOP	EAR99
ADCMP553	1	0.5	2	PECL	Fixed	Single	3.135	5.25	13	-40°C to +85°C	8-lead MSOP	EAR99
ADCMP563	2	0.7	2	ECL	Fixed	Dual	4.75	5.25	5	-40°C to +85°C	16-lead LFCSP, 16-lead QSOP	EAR99
ADCMP564	2	0.7	2	ECL	Adjustable	Dual	4.75	5.25	5	-40°C to +85°C	20-lead QSOP	EAR99
ADCMP561	2	0.75	2	PECL	Fixed	Dual	4.75	5.25	5	-40°C to +85°C	16-lead QSOP	EAR99
ADCMP562	2	0.75	2	PECL	Adjustable	Dual	4.75	5.25	5	-40°C to +85°C	20-lead QSOP	EAR99
LTC6957-2	1	0.84		LVDS		Single	3.15	3.45	45	-40°C to +85°C	12-lead MSOP, 12-lead DFN	EAR99
LTC6957-3	1	0.95		In-phase CMOS		Single	3.15	3.45	27.5	-40°C to +85°C	12-lead MSOP, 12-lead DFN	EAR99
LTC6957-4	1	0.95		Complementary CMOS		Single	3.15	3.45	27.5	-40°C to +85°C	12-lead MSOP, 12-lead DFN	EAR99
ADCMP606	1	1.2	5	CML	Fixed	Single	2.5	5.5	26	-40°C to +125°C	6-lead SC70	EAR99
ADCMP607	1	1.2	5	CML	Adjustable	Dual	2.5	5.5	25	-40°C to +125°C	12-lead LFCSP	EAR99
AD8465	1	1.6	5	LVDS	Adjustable	Dual	2.5	5.5	26	-40°C to +125°C	12-lead LFCSP	EAR99
ADCMP604	1	1.6	5	LVDS	Fixed	Single	2.5	5.5	21	-40°C to +125°C	6-lead SC70	EAR99
ADCMP605	1	1.6	5	LVDS	Adjustable	Dual	2.5	5.5	23	-40°C to +125°C	12-lead LFCSP	EAR99
LTC6754	1	1.8	0.75	LVDS	Adjustable	Single	2.4	5.25	14.7	-40°C to +85°C	6-lead SC70, 12-lead QFN	EAR99
LTC6752	1	2.9	1.2	CMOS	Adjustable	Single	2.45	5.25	5	-40°C to +125°C	5-lead SOT-23, 6-lead SC70, 8-lead MSOP, 12-lead QFN	EAR99
LTC6752-1	1	2.9	1.2	CMOS	Adjustable	Single	2.45	5.25	5	-40°C to +85°C	5-lead SOT-23, 6-lead SC70, 8-lead MSOP, 12-lead QFN	EAR99
LTC6752-2	1	2.9	1.2	CMOS	Adjustable	Single	2.45	5.25	5	-40°C to +85°C	5-lead SOT-23, 6-lead SC70, 8-lead MSOP, 12-lead QFN	EAR99
LTC6752-3	1	2.9	1.2	CMOS	Adjustable	Single	2.45	5.25	5	-40°C to +85°C	5-lead SOT-23, 6-lead SC70, 8-lead MSOP, 12-lead QFN	EAR99
LTC6752-4	1	2.9	1.2	CMOS	Adjustable	Single	2.45	5.25	5	-40°C to +85°C	5-lead SOT-23, 6-lead SC70, 8-lead MSOP, 12-lead QFN	EAR99
ADCMP600	1	3.5	2	CMOS, TTL	Fixed	Single	2.5	5.5	4	-40°C to +125°C	5-lead SC70, 5-lead SOT-23	EAR99
ADCMP601	1	3.5	2	CMOS, TTL	Adjustable	Single	2.5	5.5	4	-40°C to +125°C	6-lead SC70	EAR99
ADCMP602	1	3.5	2	CMOS, TTL	Adjustable	Dual	2.5	5.5	5.5	-40°C to +125°C	8-lead MSOP	EAR99

Comparators

Comparators (Continued)

Part Number	Number of Channels	Prop Delay V _{p-p} (typ) (ns p-p)	V _{OS} (typ) (mV)	Output Logic	Adjustable Hysteresis	V _S Type	V _S Pos-1 (min) (V)	V _{SUPPLY} Pos-1 (max) (V)	I _S Pos (max) (mA)	Temperature Range	Package	ECCN Code
ADCMP603	1	3.5	2	CMOS, TTL	Adjustable	Dual	2.5	5.5	5.3	-40°C to +125°C	12-lead LFCSP	EAR99
LT1715	2	4	0.4	CMOS	Fixed	Dual, single	2.7	12	7.5	-40°C to +125°C	10-lead MSOP	EAR99
AD8612	2	4	1	TTL	None	Single	4.5	5.5	10	-40°C to +85°C	14-lead TSSOP	EAR99
AD8611	1	4	1	TTL	None	Single	2.7	6	10	-40°C to +85°C	8-lead SOIC, 8-lead MSOP	EAR99
LT1719	1	4.2	0.4	CMOS	Fixed	Dual, Single	2.7	10.5	7	-40°C to +85°C	8-lead SOIC, 6-lead SOT-23	EAR99
LT1711	1	4.5	0.5	CMOS	None	Dual, single	2.4	12	19	-40°C to +85°C	8-lead MSOP	EAR99
LT1712	2	4.5	0.5	CMOS	None	Dual, single	2.4	12	19	-40°C to +85°C	16-lead SSOP	EAR99
LT1721	4	4.5	1	CMOS	Fixed	Single	2.7	6	7	-40°C to +85°C	16-lead SOIC, 16-lead SSOP	EAR99
LT1720	2	4.5	1	CMOS	Fixed	Single	2.7	6	7	-40°C to +85°C	8-lead SOIC, 8-lead MSOP, 8-lead DFN	EAR99
AD96685	1	6	1	ECL	Fixed	Dual	5	5	18	-25°C to +85°C	16-lead SOIC	EAR99
AD96687	2	6	1	ECL	Fixed	Dual	5	5	18	-25°C to +85°C	20-lead PLCC, 16-lead CerDip, 16-lead SOIC	EAR99
LT1714	2	7	0.5	CMOS	None	Dual, single	2.4	12	7.5	-40°C to +85°C	16-lead SSOP	EAR99
LT1713	1	7	0.5	CMOS	None	Dual, single	2.4	12	7.5	-40°C to +85°C	8-lead MSOP	EAR99
AD8564	4	7	2.3	CMOS, TTL	None	Dual	4.5	5.5	14	-40°C to +125°C	16-lead SOIC, 16-lead TSSOP	EAR99
AD8561	1	7	2.3	TTL	None	Dual	4.5	5.5	6.5	-40°C to +85°C	8-lead PDIP, 8-lead SOIC, 8-lead TSSOP	EAR99
LT1394	1	7	0.8	CMOS	None	Dual, single	4.5	10	8.5	-40°C to +85°C	8-lead SOIC, 8-lead MSOP	EAR99
LT1016	1	9	1	CMOS	None	Dual, single	4.5	10	35	-40°C to +85°C	10-lead TO-5, 8-lead PDIP, 8-lead SOIC	EAR99
LT1116	1	10	1	CMOS	None	Dual, single	4.5	10	38	0°C to 70°C	8-lead PDIP, 8-lead SOIC	EAR99
ADCMP609	1	30	3	CMOS, TTL	Adjustable	Single	2.5	5.5	1.1	-40°C to +125°C	8-lead MSOP	EAR99
ADCMP608	1	30	3	CMOS, TTL	Fixed	Single	2.5	5.5	1.3	-40°C to +125°C	6-lead SC70	EAR99
CMP401	4	33	3	CMOS, TTL	Fixed	Dual, single	0	5	6.5	-40°C to +125°C	16-lead SOIC, 16-lead TSSOP	EAR99
AD8468	1	35	3	CMOS, TTL	Fixed	Single	2.5	5.5	0.8	-40°C to +125°C	6-lead SC70	EAR99
AD790	1	45	0.2	CMOS, TTL	Fixed	Multi	15	15	10	-55 to +125°C	8-lead PDIP, 8-lead SOIC, CerDip Glass Seal	EAR99
LT1671	1	60	0.8	CMOS	None	Dual, single	4.5	10	0.8	-40°C to +85°C	8-lead SOIC, 8-lead MSOP	EAR99
CMP402	4	60	3	CMOS, TTL	Fixed	Dual, single	0	5	1.4	-40°C to +125°C	16-lead SOIC, 16-lead TSSOP	EAR99
LT1011	1	150	0.6	Open-collector	Programmable	Dual, single	3	36	4	-40°C to +85°C	8-lead PDIP, 8-lead SOIC	EAR99
LT1011A	1	150	0.3	Open-collector	Programmable	Dual, single	3	36	4	-40°C to +85°C	8-lead PDIP, 8-lead SOIC	EAR99
LT1011AMJ8	1	150	0.3	Open-collector	Programmable	Dual, single	3	36	4		8-lead PDIP, 8-lead SOIC	EAR99
LTC6702	2	320	1	CMOS	Fixed	Single	1.5	5.5	0.03	-40°C to +125°C	8-lead SOT-23, 8-lead DFN	EAR99
CMP04	4	1300	0.4	CMOS, DTL, ECL, TTL	None	Single	5	5	2	-40°C to +85°C	14-lead SOIC	EAR99
LT1716	1	3000	0.3	CMOS (up to 44 V)	None	Single	2.7	44	0.05	-40°C to +125°C	5-lead SOT-23	EAR99
LTC1841	2	4000	3	Open-drain	None	Single	2.5	12.6	0.006	-40°C to +85°C	8-lead SOIC	EAR99
LTC1842	2	4000	3	Open-drain	Programmable	Single	2	11	0.006	-40°C to +85°C	8-lead SOIC	EAR99
LTC1843	2	4000	3	Open-drain	Programmable	Single	2	11	0.006	-40°C to +85°C	8-lead SOIC	EAR99
LTC1443	4	4000	3	CMOS	Fixed	Single	2	11	0.009	-40°C to +85°C	16-lead PDIP, 16-lead SOIC, 16-lead DFN	EAR99

Comparators

Comparators (Continued)

Part Number	Number of Channels	Prop Delay V p-p (typ) (ns p-p)	V _{OS} (typ) (mV)	Output Logic	Adjustable Hysteresis	V _S Type	V _S Pos-1 (min) (V)	V _{SUPPLY} Pos-1 (max) (V)	I _S Pos (max) (mA)	Temperature Range	Package	ECCN Code
LTC1444	4	4000	3	CMOS	Programmable	Single	11	11	0.009	-40°C to +85°C	16-lead PDIP, 16-lead SOIC, 16-lead DFN	EAR99
LTC1445	4	4000	3	CMOS	Programmable	Single	2	11	0.009	-40°C to +85°C	16-lead PDIP, 16-lead SOIC, 16-lead DFN	EAR99
ADCMP391	1	4500	0.5	Open-drain	Fixed	Single	2.3	5.5	0.025	-40°C to +125°C	8-lead SOIC	EAR99
ADCMP392	2	4500	0.5	Open-drain	Fixed	Single	2.3	5.5	0.029	-40°C to +125°C	8-lead SOIC	EAR99
ADCMP393	4	4500	0.5	Open-drain	Fixed	Single	2.3	5.5	0.037	-40°C to +125°C	14-lead SOIC, 14-lead TSSOP	EAR99
ADCMP396	4	4940	0.5	Open-drain	Fixed	Single	2.3	5.5	0.042	-40°C to +125°C	16-lead SOIC	EAR99
ADCMP361	1	5000		Open-drain	Fixed	Single	1.7	5.5	0.01	-40°C to +125°C	5-lead SOT-23	EAR99
ADCMP350	1	5000		Active-low, Open-drain	Fixed	Single	2.25	5.5	0.015	-40°C to +125°C	4-lead SC70	EAR99
ADCMP354	1	5000		Active-high, Open-drain	Fixed	Single	2.25	5.5	0.015	-40°C to +125°C	4-lead SC70	EAR99
ADCMP356	1	5000		Active-high, Push-pull	Fixed	Single	2.25	5.5	0.015	-40°C to +125°C	4-lead SC70	EAR99
ADCMP370	1	5000	6	Open-drain	Fixed	Single	2.25	5.5	0.007	-40°C to +85°C	5-lead SC70	EAR99
ADCMP371	1	5000	6	Push-pull	Fixed	Single	2.25	5.5	0.007	-40°C to +85°C	5-lead SC70, chips or die	EAR99
LT1018	2	6000	0.4	CMOS	None	Single	1.2	40	0.25	-40°C to +85°C	8-lead PDIP, 8-lead SOIC, 16-lead SOIC	EAR99
LTC1542	1	8000	1	CMOS	Fixed	Single	2.5	12.6	0.01	-40°C to +85°C	8-lead SOIC, 8-lead MSOP, 8-lead DFN	EAR99
LTC1541	1	8000	1	CMOS	Fixed	Single	2.5	12.6	0.01	-40°C to +85°C	8-lead SOIC, 8-lead MSOP, 8-lead DFN	EAR99
LTC1440	1	8000	3	CMOS	Programmable	Single	2	11	0.004	-40°C to +85°C	8-lead PDIP, 8-lead SOIC, 8-lead MSOP, 8-lead DFN	EAR99
LTC1441	2	8000	3	CMOS	Programmable	Single	2	11	0.006	-40°C to +85°C	8-lead PDIP, 8-lead SOIC	EAR99
LTC1442	2	8000	3	CMOS	Programmable	Single	2	11	0.006	-40°C to +85°C	8-lead PDIP, 8-lead SOIC	EAR99
ADCMP394	1	9500	1	Open-drain	Fixed	Single	2.3	5.5	0.048	-40°C to +125°C	8-lead SOIC	EAR99
ADCMP395	2	9500	1	Open-drain	Fixed	Single	2.3	5.5	0.052	-40°C to +125°C	10-lead MSOP	EAR99
ADCMP671	2	10,000		Open-drain	Fixed	Single	1.7	5.5	0.011	-40°C to +125°C	6-lead TSOT	EAR99
ADCMP341	2	10,000		Open-drain	Adjustable	Single	1.7	5.5	0.009	-40°C to +125°C	8-lead SOT-23	EAR99
ADCMP343	2	10,000		Open-drain	Adjustable	Single	1.7	5.5	0.009	-40°C to +125°C	8-lead SOT-23	EAR99
ADCMP670	2	10,000		Open-drain	Fixed	Single	1.7	5.5	0.011	-40°C to +125°C	6-lead TSOT	EAR99
LT6703-2	1	18,000	5	Open-collector	Fixed	Single	1.4	18	0.011	0°C to 70°C	5-lead SOT-23, 3-lead DFN	EAR99
LT6703-3	1	18,000	5	Open-collector	Fixed	Single	1.4	18	0.011	0°C to 70°C	5-lead SOT-23, 3-lead DFN	EAR99
LT6703HV-2	1	18,000	5	Open-collector	Fixed	Single	1.4	18	0.011	0°C to 70°C	5-lead SOT-23, 3-lead DFN	EAR99
LT6703HV-3	1	18,000	5	Open-collector	Fixed	Single	1.4	18	0.011	0°C to 70°C	5-lead SOT-23, 3-lead DFN	EAR99
LT6700-1	2	18,000	6	Open-collector	Fixed	Single	1.4	18	0.011	0°C to 70°C	6-lead SOT-23, 6-lead DFN	EAR99
LT6700-2	2	18,000	6	Open-collector	Fixed	Single	1.4	18	0.011	0°C to 70°C	6-lead SOT-23, 6-lead DFN	EAR99
LT6700-3	2	18,000	6	Open-collector	Fixed	Single	1.4	18	0.011	0°C to 70°C	6-lead SOT-23, 6-lead DFN	EAR99
LT6700HV-1	2	18,000	6	Open-collector	Fixed	Single	1.4	18	0.011	0°C to 70°C	6-lead SOT-23, 6-lead DFN	EAR99
LT6700HV-2	2	18,000	6	Open-collector	Fixed	Single	1.4	18	0.011	0°C to 70°C	6-lead SOT-23, 6-lead DFN	EAR99

Comparators

Comparators (Continued)

Part Number	Number of Channels	Prop Delay V _{p-p} (typ) (ns p-p)	V _{os} (typ) (mV)	Output Logic	Adjustable Hysteresis	V _s Type	V _s Pos-1 (min) (V)	V _{SUPPLY} Pos-1 (max) (V)	I _s Pos (max) (mA)	Temperature Range	Package	ECCN Code
LT6700HV-3	2	18,000	6	Open-collector	Fixed	Single	1.4	18	0.011	0°C to 70°C	6-lead SOT-23, 6-lead DFN	EAR99
LT1017	2	22,000	0.4	CMOS	None	Single	1.2	40	0.06	-40°C to +85°C	8-lead PDIP, 8-lead SOIC, 16-lead SOIC	EAR99
ADCMCP380	1	23,000		Open-drain	Fixed	Single	0.9	5.5	0.00019	-40°C to +85°C	6-ball WLCSFP	EAR99
LTC1540	1	50,000	12	CMOS	Programmable	Single	2	11	0.01	-40°C to +85°C	8-lead SOIC, 8-lead MSOP, 8-lead DFN	EAR99
LTC1042	2	80,000	0.3	CMOS, TTL	None	Single	1.4	18	0.005	0°C to 70°C	8-lead PDIP	EAR99
LTC1042MJ8	2	80,000	0.3	CMOS, TTL	None	Single	1.4	18	0.005		8-lead PDIP	EAR99
LTC1040	2	80,000	0.3	CMOS, TTL	None	Single	1.4	18	0.006	0°C to 70°C	18-lead PDIP, 18-lead SOIC	EAR99
LTC1041	2	80,000	0.3	CMOS, TTL	Programmable	Single	1.4	18	0.005	0°C to 70°C	8-lead PDIP, 8-lead SOIC	EAR99
LTC1998	1	15,000	5	CMOS	Programmable	Single	1.5	5.5	0.004	-40°C to +85°C	6-lead SOT-23	EAR99
LTC1921	2	220,000			Fixed	Single	2	11	0.25	-40°C to +85°C	8-lead SOIC, 8-lead MSOP	EAR99

Precision ADCs

AD400x Family: 20-/18-/16-Bit, 2 MSPS to 0.5 MSPS, Differential Input/Pseudo Differential Input, SAR ADCs

Key Features

- ▶ Input span compression
 - Preserves ADC full code range when drive amplifier and ADC operate off same supply
- ▶ Input overvoltage clamp circuit
- ▶ Guaranteed 16-/18-/20-bit no missing codes
- ▶ Throughput: 0.5 MSPS/1 MSPS/1.8 MSPS/2 MSPS max
- ▶ Single, 1.8 V supply operation with 1.71 V to 5.5 V logic interface
- ▶ Temperature range: -40°C to $+125^{\circ}\text{C}$
- ▶ SAR architecture: no latency/pipeline delay
- ▶ Serial interface SPI-/QSPI-/MICROWIRE-/DSP-compatible
- ▶ Ability to daisy-chain multiple ADCs and busy indicator
- ▶ 10-lead package: 3 mm \times 3 mm LFCSP and 3 mm \times 4.90 mm MSOP

Key Benefits

- ▶ Ease of drive: high-Z mode plus long acquisition phase enables the use of low power precision ADC drive amplifier when the bandwidth of interest is low
 - Reduces signal chain power consumption
- ▶ Ease of digital interface: low SPI clock rate requirements reduce I/O power consumption and simplify the requirements on digital isolation
- ▶ Reduced sensitivity to external circuitry: performance sensitivity to resistor values in RC noise filter reduced

Applications

- ▶ Automatic test equipment
- ▶ Machine automation
- ▶ Medical equipment
- ▶ Battery-powered equipment
- ▶ Precision data acquisition systems

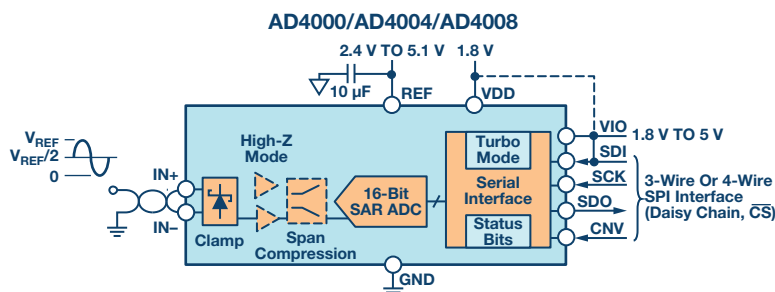

Part Number	Resolution	Speed (MSPS)	Input	Power (mW)	INL	SNR (typ @ 1 kHz) (dB)	THD (typ @ 1 kHz) (dB)	Package
AD4000	16-bit	2	Pseudo differential	14	± 1 LSB	93	-115	10-lead MSOP, 10-lead LFCSP
AD4001	16-bit	2	Differential	16	± 0.4 LSB	96.2	-123	10-lead MSOP, 10-lead LFCSP
AD4002	18-bit	2	Pseudo differential	14	± 2.0 LSB	95	-120	10-lead MSOP, 10-lead LFCSP
AD4003	18-bit	2	Differential	16	± 1.0 LSB	100.5	-123	10-lead MSOP, 10-lead LFCSP
AD4004	16-bit	1	Pseudo differential	7	± 1 LSB	93	-115	10-lead MSOP, 10-lead LFCSP
AD4005	16-bit	1	Differential	8	± 0.4 LSB	96.2	-123	10-lead MSOP, 10-lead LFCSP
AD4006	18-bit	1	Pseudo differential	7	± 2.0 LSB	95	-120	10-lead MSOP, 10-lead LFCSP
AD4007	18-bit	1	Differential	8	± 1.0 LSB	100.5	-123	10-lead MSOP, 10-lead LFCSP
AD4008	16-bit	0.5	Pseudo differential	3.5	± 1 LSB	93	-115	10-lead MSOP, 10-lead LFCSP
AD4010	18-bit	0.5	Pseudo differential	3.5	± 2.0 LSB	95	-120	10-lead MSOP, 10-lead LFCSP
AD4011	18-bit	0.5	Differential	4	± 1.0 LSB	100.5	-123	10-lead MSOP, 10-lead LFCSP
AD4020	20-bit	1.8	Differential	15	± 3.1 ppm (max)	101	-123	10-lead MSOP, 10-lead LFCSP

Precision ADCs

Precision ADCs

Key

- ~ Identifies ADCs that are optimized to maintain SINAD performance at high input signal frequencies within the Nyquist bandwidth of the ADC.
- ▶ Buffered input: Identifies ADCs that incorporate buffers on the analog inputs. These ADCs offer substantial space and cost savings by eliminating front-end signal conditioning circuitry normally required to drive unbuffered switched-capacitor ADC inputs.
- ✦ PGA input: Identifies ADCs that incorporate a PGA (programmable gain instrumentation amplifier) on the analog inputs. The high input impedance and programmable signal scaling functionality enable direct interface to sensor outputs.
- ∞ Resistive input: Identifies ADCs that have a resistive input structure on the analog inputs. This input structure type enables true bipolar analog input signals to be connected directly to an ADC that operates off a single unipolar supply rail. These ADCs are ideally suited for direct connection to low output impedance sensors such as current transformers and voltage transformers and eliminate the need for front-end signal conditioning circuitry normally required to drive the ADC.
- Suggested part for that given cell. The ADCs are categorized by resolution, sampling rate, and input channel count.
- Indicates that the ADC is higher performance vs. a similar product in same cell.
- Indicates that the ADC enables a smaller solution size vs. a similar product in same cell. The ADC may have a smaller package footprint or integrate additional functionality such as voltage references, reference buffers, input buffers, or PGAs.
- Indicates that the ADC enables lower power vs. a similar product in same cell. The ADC may have lower power consumption at the component level or may enable lower power at the signal chain level due to its ease of use features.

Single-Channel SAR ADCs

Input Type	≤200 kSPS	≤250 kSPS	≤500 kSPS	≤1 MSPS	≤1.8 MSPS	≤2 MSPS	≤6 MSPS	≤10 MSPS	≤15 MSPS
<i>24-Bit</i>									
Fully differential						■ LTC2380-24			
Pseudo differential				■ LTC2368-24					
<i>20-Bit</i>									
Fully differential		■ LTC2376-20	■ LTC2377-20	■ LTC2378-20	■ AD4020~				
<i>18-Bit</i>									
Fully differential	■ AD7989-1	■ LTC2376-18 ■ AD7691	■ LTC2377-18 ■ AD4011~	■ LTC2378-18 ■ AD4007~	■ LTC2379-18 ■ AD7984	■ AD4003~ ■ AD7986	■ LTC2385-18~ ■ AD7960~	■ LTC2386-18~	■ LTC2387-18~
Fully differential ±10 V true bipolar		■ LTC2336-18~	■ LTC2337-18~	■ LTC2338-18~					
Pseudo differential		■ LTC2364-18	■ LTC2367-18	■ LTC2368-18	■ LTC2369-18	■ LTC2389-18			
Pseudo differential ±10 V true bipolar		■ LTC2326-18∞	■ LTC2327-18∞	■ LTC2328-18∞					
<i>16-Bit</i>									
Fully differential		■ LTC2376-16 ■ AD7687	■ LTC2377-16	■ LTC2378-16 ■ AD4005~		■ LTC2380-16 ■ AD4001~ ■ LTC2310-16~	■ LTC2385-16~ ■ AD7961~ ■ LTC2311-16~	■ LTC2386-16~ ■ AD7626~	■ LTC2387-16~
Fully differential ±2.5 V true bipolar		■ LTC1603	■ LTC1604 ■ LTC1608						
Pseudo differential unipolar	■ AD7683 ■ AD7988-1	■ LTC2364-16 ■ AD7685 ■ AD7694	■ LTC2367-16 ■ AD7686 ■ AD7988-5	■ LTC2368-16 ■ AD7981 ■ AD4004~	■ AD7983	■ LTC2370-16 ■ AD4000~	■ AD7985		
Pseudo differential true bipolar		■ LTC2326-16∞	■ LTC2327-16∞	■ LTC2328-16∞					
Single-ended ±10 V true bipolar	■ LTC1605∞ ■ LTC1609∞	■ LTC1606							

Precision ADCs

Single-Channel SAR ADCs (Continued)

Input Type	≤100 kSPS	≤250 kSPS	≤500 kSPS	≤1.5 MSPS	≤3 MSPS	≤6 MSPS
<i>14-Bit</i>						
Differential with wide input Common mode					■ LTC1403A~ ■ LTC2310-14~	■ LTC2355-14~ ■ LTC2356-14~ ■ LTC2311-14~
Fully differential ±10 V true bipolar			■ AD7899	■ AD7951		
Pseudo differential		■ AD7942	■ AD7946		■ AD7944 ■ LTC1403A~ ■ LTC2310-14~	■ LTC2355-14~ ■ LTC2356-14~ ■ LTC2311-14~
Pseudo differential ±10 V true bipolar				■ AD7951		
Single-ended unipolar	■ AD7940		■ LTC2312-14~	■ AD7485	■ AD7484 ■ LTC2313-14~	■ LTC2314-14~
Single-ended ±10 V true bipolar		■ AD7894				
<i>12-Bit</i>						
Fully differential			■ AD7452	■ AD7450A		
Differential with wide input Common mode					■ LTC1403~ ■ LTC2310-12~	■ LTC2355-12~ ■ LTC2356-12~ ■ LTC2311-12~
Pseudo differential	■ AD7457 ■ LTC2301*	■ LTC1860	■ AD7453 ■ LTC2302	■ AD7472	■ LTC1403~ ■ LTC2310-12~	■ LTC2355-12~ ■ LTC2356-12~ ■ LTC2311-12~
Single-ended unipolar	■ AD7466		■ LTC2312-12~	■ AD7091 ■ AD7091R	■ AD7274 ■ AD7276 ■ AD7482 ■ LTC2313-12~	■ LTC2315-12~
Single-ended ±10 V true bipolar	■ AD7893	■ AD7895 ■ AD7898				

■ Suggested part
■ Higher performance
■ Lower power

* I²C
~ Improved SINAD at high F_M

µModule Data Acquisition Systems

Resolution	Input Type	Max Output Data Rate		
		≤500 kSPS	≤1 MSPS	≤2 MSPS
16-bit	Pseudo differential	■ ADAQ7988	■ ADAQ7980	
18-bit	Fully differential			■ ADAQ4003 <i>Coming Soon</i>

Precision ADCs

AD7768/AD7768-4: 8-Channel/4-Channel, 24-Bit Simultaneous Sampling, Σ - Δ ADCs with Power Scaling

Key Features

- ▶ 8-channel/4-channel simultaneous sampling
- ▶ Power and bandwidth scaling
- ▶ Precharge input buffers for ease of drive
- ▶ Flexible digital filter choice
- ▶ Multiple decimation rates
- ▶ Analog input range \pm VREF (VREF = 4.096 V typical)
- ▶ Modes configured by pin or register
- ▶ Data interface CRC mode
- ▶ 5 V analog supply

Benefits

- ▶ Increased density
 - Eight high dynamic range ADCs with reference buffers and power management in 12 mm \times 12 mm footprint
- ▶ Easy to drive
 - Precharge buffers reduce charge kick back and reduce the signal dependent input current
 - Common-mode voltage for input signal provided

- ▶ Power modes
 - User can scale bandwidth for lower power
- ▶ Configurable
 - Bandwidth can be scaled for higher dynamic range
 - Selectable filters for wide bandwidth or low latency

Applications

- ▶ Data acquisition systems: USB/PXI/Ethernet
- ▶ Instrumentation and industrial control loops
- ▶ Audio test and measurement
- ▶ Vibration and asset condition monitoring
- ▶ 3-phase power quality analysis
- ▶ Sonar
- ▶ High precision medical electroencephalogram (EEG)/electromyography (EMG)/electrocardiogram (ECG)

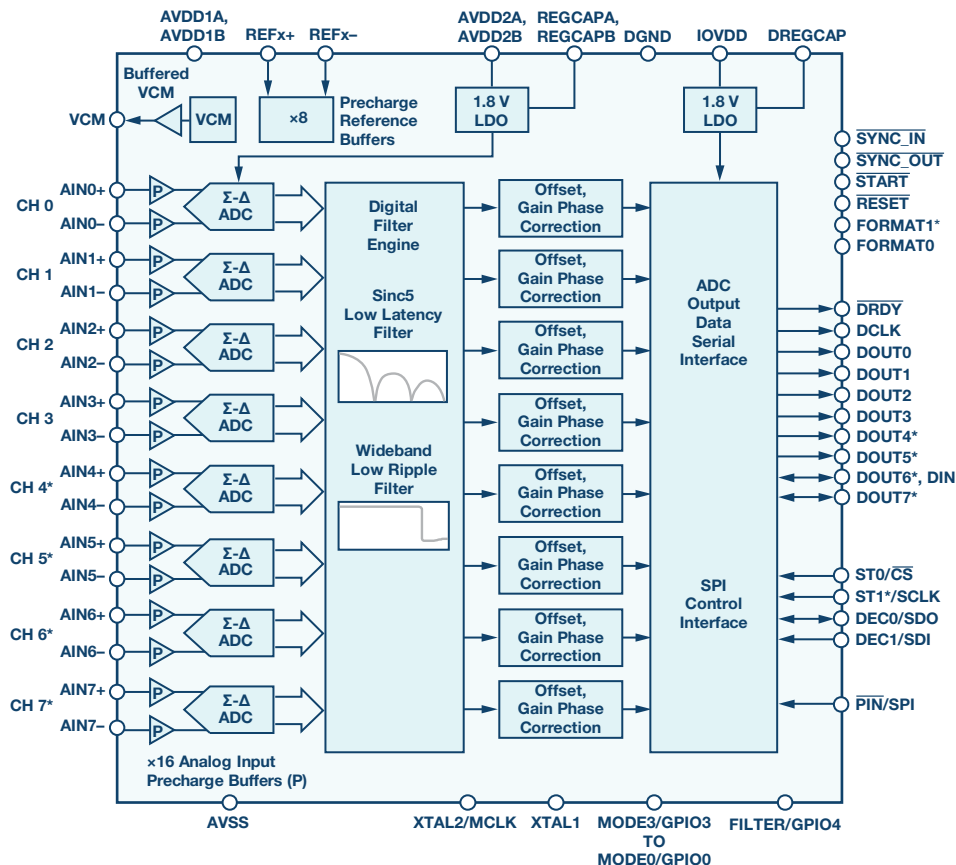

*These channels/pins exist only on the AD7768.

Precision ADCs

AD4111/AD4112: Low Power, 24-Bit, Σ - Δ ADC with ± 10 V and 0 mA to 20 mA Inputs

Key Features

- ▶ 24-bit ADC with integrated analog front end
 - Up to 6.2 kSPS/channel
 - 16 noise free bits at 1 kSPS/channel, 19 NFB at 20 SPS/channel
 - 90 dB (typ) rejection of 50 Hz and 60 Hz at 16.67 SPS/channel
- ▶ ± 10 V voltage inputs, 4 differential and 8 single-ended
 - Overrange, up to ± 20 V input voltage (with 5 V power supply)
 - Overvoltage tolerant ± 50 V (absolute max ratings)
 - ≥ 1 M Ω impedance
 - Voltage: $\pm 0.06\%$ (max) 25°C
 - Open wire detection: AD4111
- ▶ 0 mA to 20 mA current inputs, 4 single-ended
 - Over range, up to -0.5 mA to $+24$ mA,
 - 60 Ω input impedance
 - Current: $\pm 0.08\%$ (max) 25°C

Benefits

- ▶ The AD411x offers a high degree of system integration with a high level of accuracy reduces overall system level and manufacturing cost
- ▶ The AD411x provides simplified signal chain and easy configuration for faster time to market

Applications

- ▶ Process control
 - PLC and DCS modules

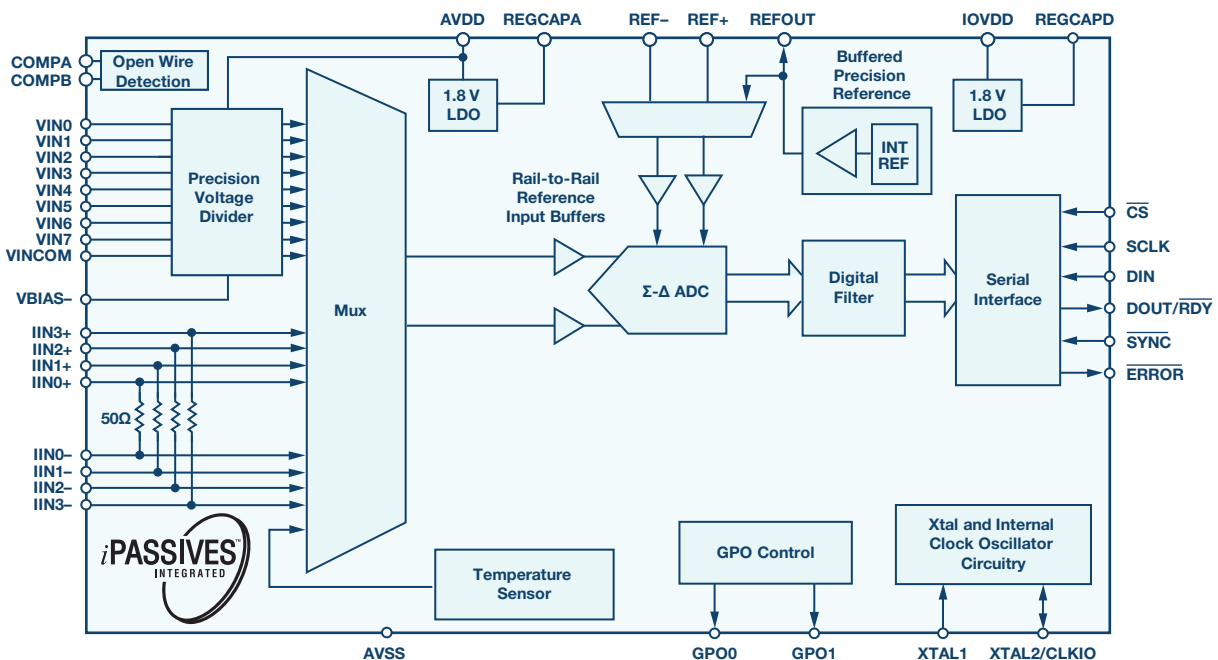

Precision ADCs

LTC2358 Family: Buffered Octal, 16-/18-Bit, 200 kSPS/Channel Differential ± 10.24 V ADC with 30 V p-p Common-Mode Range

Key Features

- ▶ **LTC2358-16**: guaranteed 16-bit, no missing codes
- ▶ **LTC2358-18**: guaranteed 18-bit, no missing codes
- ▶ 200 kSPS per channel throughput
- ▶ Eight buffered simultaneous sampling channels
- ▶ Differential, 30 V p-p common-mode range inputs
- ▶ Per channel SoftSpan™ input ranges:
 - ± 10.24 V, 0 V to 10.24 V, ± 5.12 V, 0 V to 5.12 V
 - ± 12.5 V, 0 V to 12.5 V, ± 6.25 V, 0 V to 6.25 V
- ▶ 96.4 dB single-conversion SNR (typical)
- ▶ 48-lead (7 mm \times 7 mm) LQFP package

Benefits

- ▶ Integrated front-end buffers enable ADC to connect directly to a wide range of sensors without compromising measurement accuracy
- ▶ Saves significant board space, power consumption, and component cost
 - Eliminate up to 88 analog components with a single part

Applications

- ▶ Programmable logic controllers
- ▶ Industrial process control
- ▶ Power line monitoring
- ▶ Test and measurement

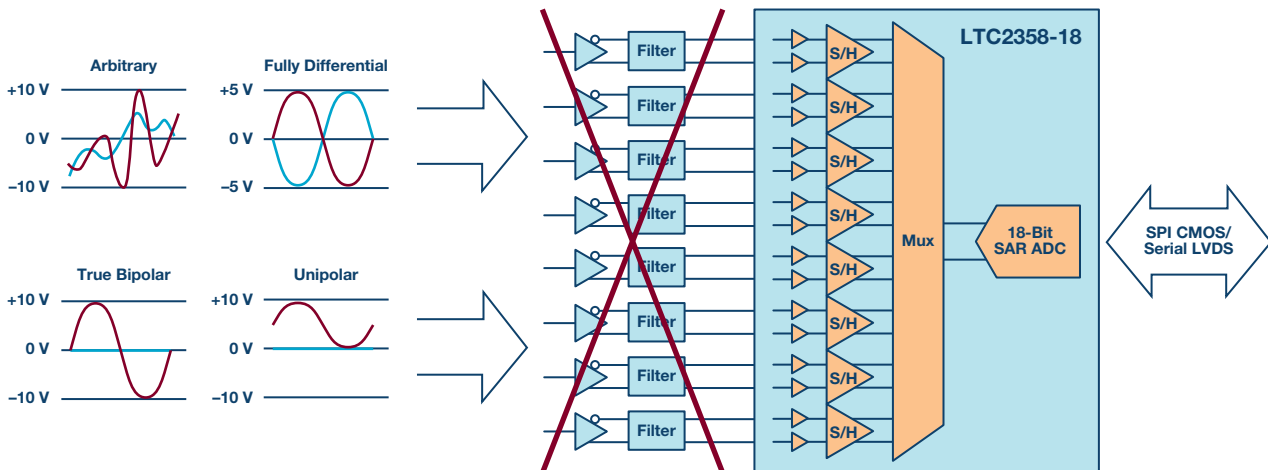

Precision ADCs

Simultaneous Sampling ADCs (High Resolution)

Input Type	Channels	≤200 kSPS/Channel	≤400 kSPS/Channel	≤700 kSPS/Channel	≤1 MSPS/Channel	≤2 MSPS/Channel	≤5 MSPS/Channel
<i>24-Bit</i>							
Fully differential/ single-ended	16	■ AD4111 <i>New</i> ■ AD4112 <i>New</i>					
Fully differential/ pseudo differential	8	■ AD7779 † ■ AD7770 † ■ AD7771 †	■ AD7768				
	4		■ AD7768-4				
<i>18-Bit</i>							
Differential with wide input common mode	2			■ LTC2341-18			
	4		■ LTC2344-18				
	8	■ LTC2345-18					
Differential ±10 V true bipolar	2			■ LTC2353-18 ▶			
	4		■ LTC2357-18 ▶				
	8	■ AD7609 ** ■ LTC2358-18 ▶ ■ LTC2348-18					
Pseudo differential true bipolar	8	■ AD7608 **					
<i>16-Bit</i>							
Fully differential	2				■ AD7903		■ AD7380 <i>New</i>
Differential with wide input common mode	2			■ LTC2341-16		■ LTC2321-16 ~	■ LTC2323-16 ~
	4		■ LTC2344-16			■ LTC2324-16 ~	■ LTC2325-16 ~
	8	■ LTC2345-16	■ AD7761			■ LTC2320-16 ~	
Differential ±10 V true bipolar	2			■ LTC2353-16 ▶			
	4		■ LTC2357-16 ▶				
	8	■ LTC2348-16 ■ LTC2358-16 ▶					
Pseudo differential single-ended	2			■ LTC2341-16	■ AD7902		
	4		■ LTC2344-16				
	8	■ LTC2345-16					
Pseudo differential ±10 V true bipolar	4	■ AD7606-4 **	■ AD7605-4 **				
	6	■ AD7606-6 **	■ AD7656A/ AD7656A-1				
	8	■ ADAS3023 † ■ AD7606 ** ■ AD7606B <i>New</i> ** ■ LTC2358-16 ▶ ■ LTC2348-16					

- Suggested part
- Higher performance
- Smaller solution
- * IFC
- ~ Improved SINAD at high F_N
- ▶ Buffered input
- † PGA input
- ** Resistive input

Precision ADCs

AD7380/AD7381: Tiny Differential Input, Dual Simultaneous Sampling 16-/14-Bit SAR ADCs

Key Features

- ▶ **AD7380:** 16-bit no missing codes, 4 MSPS/channel
- ▶ **AD7381:** 14-bit no missing codes, 4 MSPS/channel
- ▶ Fully differential analog inputs with wide common-mode range
- ▶ On-chip oversampling with resolution boost function
 - SNR 102.8 dB (typical) with $\times 32$ OSR
- ▶ 92.5 dB single-conversion SNR (typical)
- ▶ 2.5 V internal reference at 10 ppm/ $^{\circ}$ C
- ▶ 16-lead, 3 mm \times 3 mm LFCSP package

Benefits

- ▶ 4 MSPS/channel sample rate enables more sample points to improve system responsiveness and control efficiency in motor control, EDFA, and general-purpose DAQ modules. A high sample rate also enables transient detection.
- ▶ Tiny 3 mm \times 3 mm package allows smaller sized instruments and measurement systems that can be placed closer to the sensors being measured. In addition, a small form factor enables an increased number of data acquisition channels in the same form factor.

- ▶ Longer acquisition time, wide input common mode, and built-in oversampling capability simplify the front-end design—enabling faster adoption (TTM), lower costs, and smaller size implementations.
- ▶ Advanced configurability and flexible built-in OS capability allow hardware platform designs that are easy to tailor to specific application needs. A family of 16-/14-/12-bit ADCs allows for an easy path to system performance upgrades.

Applications

- ▶ Motor control position feedback
- ▶ Motor control current sense
- ▶ Sonar
- ▶ Power quality
- ▶ Data acquisition systems
- ▶ EDFA applications
- ▶ I&Q demodulation

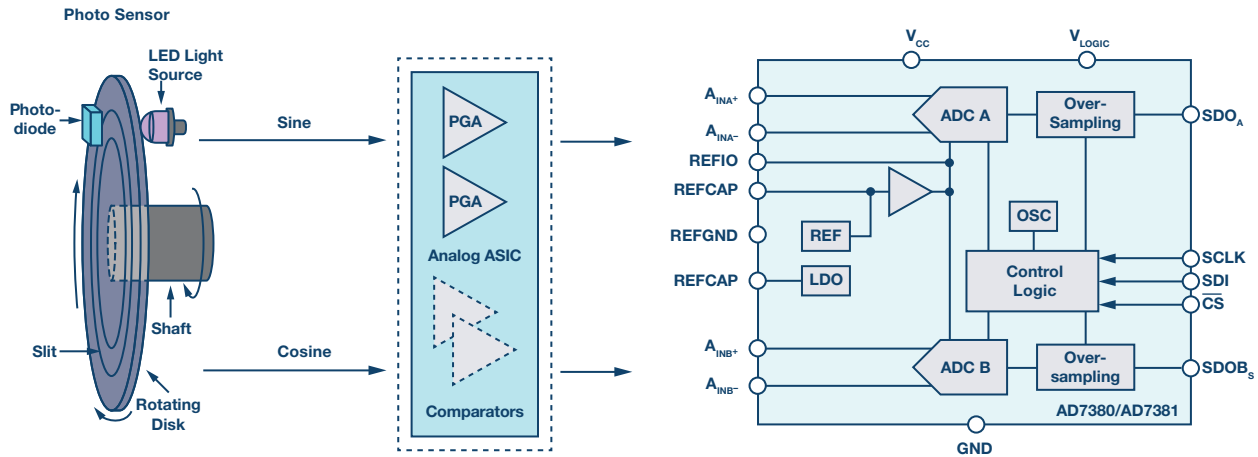

Precision ADCs

Simultaneous Sampling ADCs

Input Type	Channels	<150 kSPS/Channel	≤400 kSPS/Channel	≤1 MSPS/Channel	≤2 MSPS/Channel	≤5 MSPS/Channel
<i>14-Bit</i>						
Fully differential	2			■ AD7264 ‡		■ AD7381 <i>New</i>
Differential with wide input common mode	2				■ LTC1407A ~ ■ LTC2321-14 ~	■ LTC2323-14 ~ ■ AD7357 ~
	4				■ LTC2324-14 ~	■ LTC2325-14 ~
	6	■ LTC1408 ~	■ LTC2351-14 ~			
	8				■ LTC2320-14 ~	
Pseudo differential ±10 V true bipolar	6		■ AD7657			
	8	■ AD7607 ~				
<i>12-Bit</i>						
Fully differential	2			■ AD7265 ■ AD7262 ‡	■ AD7266	
Differential with wide input common mode	2				■ LTC1407 ~ ■ LTC2321-12 ~	■ LTC2323-12 ~ ■ AD7352 ~ ■ AD7356 ~
	4				■ LTC2324-12 ~	■ LTC2325-12 ~
	6	■ LTC1408-12 ~	■ LTC2351-12 ~			
	8				■ LTC2320-12 ~	
Pseudo differential ±10 V true bipolar	6		■ AD7658			

■ Suggested part ~ Improved SINAD at high F_{IN}
 ■ Higher performance ‡ PGA input
 ■ Lower Power ~ Resistive input

Isolated Σ - Δ Modulators

Channels	Interface	Integrated	Isolated Working Voltage		
			400 V rms	750 V rms Reinforced	884 V rms
1	CMOS	Clock	■ AD7400A		■ AD7402
1	CMOS		■ AD7401A	■ ADuM7701 <i>New</i> ■ ADuM7701-8 <i>New</i>	■ AD7403
1	LVDS				■ AD7405
2	SPI	<i>isoPower</i> ®	■ ADE7912		
2	CMOS	<i>isoPower</i>	■ ADE7932		
3	SPI	<i>isoPower</i>	■ ADE7913		
3	CMOS	<i>isoPower</i>	■ ADE7933		

■ ±250 mV analog input range
 ■ ±500 mV, ±31.25 mV analog input range

Precision ADCs

Muxed Input SAR ADCs

Input Type	Channels	≤250 kSPS	≤500 kSPS	≤1 MSPS	≤1.6 MSPS
<i>18-Bit</i>					
Fully differential	8		■ LTC2372-18	■ LTC2373-18	
Fully differential ±10 V true bipolar	8			■ LTC2333-18 ▶ ■ LTC2335-18	
Pseudo differential	8		■ LTC2372-18		
Pseudo differential ±10 V true bipolar	8			■ LTC2333-18 ▶	
<i>16-Bit</i>					
Fully differential	8		■ LTC2372-16	■ LTC2373-16	■ LTC2374-16
Fully differential ±10 V true bipolar	8	■ LTC1856 ^{www} ■ LTC1859 ^{www}		■ LTC2333-16 ▶ ■ LTC2335-16	
Pseudo differential	2	■ LTC1865			
	4	■ AD7682			
	8	■ LTC1867 ■ AD7689	■ LTC2372-16 ■ AD7699	■ LTC2373-16 ■ ADAS3022 †	
Pseudo differential ±10 V true bipolar	8	■ LTC1856 ^{www} ■ LTC1859 ^{www}		■ LTC2333-16 ▶ ■ ADAS3022 †	
	16			■ AD7616 ^{www}	
<i>14-Bit</i>					
Fully differential	4	■ LTC1855 ^{www} ■ LTC1858 ^{www}			
Pseudo differential	8	■ AD7949			
Pseudo differential ±10 V true bipolar	8	■ LTC1855 ^{www} ■ LTC1858 ^{www}			
<i>12-Bit</i>					
Fully differential	4		■ LTC1853		■ LTC1851
Fully differential ±10 V true bipolar	4	■ LTC1854 ^{www} ■ LTC1857 ^{www}			
Pseudo differential	2	■ AD7921 ■ LTC2305 * ■ LTC1861	■ LTC2306	■ AD7922 ■ AD7091R-2	
	4	■ AD7091R-5 * ■ AD7923	■ AD7934-6	■ AD7924 ■ AD7091R-4	■ AD7934
	8	■ LTC1863 ■ AD7927 ■ LTC2309 * ■ AD7998 *	■ LTC2308 ■ AD7938-6 ■ LTC1853	■ AD7091R-8	■ LTC1851 ■ AD7938
	16			■ AD7490	
Pseudo differential ±10 V true bipolar	2		■ AD7321	■ AD7322	
	4		■ AD7323	■ AD7324	
	8	■ LTC1854 ^{www} ■ LTC1857 ^{www}		■ AD7329 ■ AD7328	
<i>10-Bit</i>					
Single-ended unipolar	2	■ AD7911		■ AD7912	
	4	■ AD7995 *		■ AD7914	■ AD7933
	8	■ AD7997 *		■ AD7918	■ AD7939

■ Suggested part
■ Higher performance
■ Smaller solution
■ Lower power
* I²C
▶ Buffered input
† PGA input
www Resistive input

Wideband Oversampled ADCs (FIR Filter)

Input Type	Digital Filter Bandwidth (-3 dB Point)						
	≤5 kHz	≤12.5 kHz	≤25 kHz	≤50 kHz	≤125 kHz	≤250 kHz	≤1 MHz
<i>32-Bit</i>							
Fully differential	■ LTC2508-32					■ LTC2500-32	
<i>24-Bit</i>							
Fully differential	■ AD7767-2 ■ AD7766-2	■ AD7767-1 ■ AD7766-1	■ AD7767 ■ AD7766 ■ AD7765 ▶	■ AD7764 ▶ ■ AD7768-1	■ AD7762 ▶ ■ AD7763 ▶ ■ LTC2512-24		■ AD7760 ▶

▶ Buffered input

Precision ADCs

Narrow-Band Oversampling ADCs

Input Type	Channels	Output Data Rate						
		≤0.05 kSPS	≤0.5 kSPS	≤5 kSPS	≤20 kSPS	≤50 kSPS	≤250 kSPS	≤2 MSPS
<i>32-Bit</i>								
Fully differential/pseudo differential	2/4				■ AD7177-2 ▶			
<i>24-Bit</i>								
Fully differential	1	■ LTC2400 ■ LTC2484 ■ LTC2485*		■ LTC2440				■ LTC2380-24
Pseudo differential	1							■ LTC2368-24
Fully differential/pseudo differential	1/1		■ AD7797 †					
	2/2		■ AD7191 †					
	2/4			■ AD7190 † ■ AD7192 † ■ AD7195 †		■ AD7172-2 ▶	■ AD7175-2 ▶ ■ AD7176-2	
	3/3		■ AD7793 † ■ AD7799 †					
	4/7 or 8			■ AD7193 †	■ AD7124-4 †	■ AD7172-4 ▶		
	6/6		■ AD7794 †					
	8/15 or 16			■ AD7194 †	■ AD7124-8 †	■ AD7173-8 ▶	■ AD7175-8 ▶	
Fully differential/single-ended	2/4	■ LTC2492 ■ LTC2493*			■ LTC2442			
	4/8				■ LTC2444 ■ LTC2445 ■ LTC2446 ■ LTC2447			
	8/16	■ LTC2498 ■ LTC2499*			■ LTC2448 ■ LTC2449			
<i>16-Bit</i>								
Fully differential	1	■ LTC2452 ■ LTC2462 ■ LTC2482 ■ LTC2453* ■ LTC2463* ■ LTC2483*		■ LTC2472 ■ LTC2473*				
Fully differential/pseudo differential	1/1		■ AD7796 †					
	3/3		■ AD7792 † ■ AD7798 †					
	6/6		■ AD7795 †					
Fully differential/single-ended	2/4	■ LTC2488 ■ LTC2489* ■ LTC2486 † ■ LTC2487* †						
	8/16	■ LTC2496 ■ LTC2497* ■ LTC2494 ■ LTC2495* †						
Single-ended	1	■ LTC2450 ■ LTC2451* ■ LTC2460 ■ LTC2461*		■ LTC2470 ■ LTC2471*				

- Suggested part
- ▶ Buffered input
- † PGA input
- * IFC

Precision DACs

Voltage Output (V_{out}) DACs

Key

- Suggested part for that given cell. The DACs are categorized by resolution, sampling rate, and input channel count.
- Higher accuracy—Indicates that the DAC is higher precision (better INL, noise, glitch) vs. a similar product in same cell.
- Lower power—Indicates that the DAC enables lower power operation vs. a similar product in same cell.
- Smaller solution—Indicates that the DAC enables a smaller solution size vs. a similar product in same cell. The DAC may have a smaller package footprint or integrate additional functionality such as output amplifiers or monitoring multiplexers.
- ≥9 I²C addresses—Indicates that the DAC may be configured for nine or more I²C user-selectable slave addresses, allowing many DACs on the same bus and minimizing address conflicts with other components.
- Lower glitch—Indicates lower mid-scale glitch impulse vs. a similar product in same cell, making it possible to produce higher frequency, lower noise output waveforms.
- ADC/DAC combo—These devices offer ADCs, DACs, GPIO, and temperature sensor functionality in a single IC.
- >5 MHz bandwidth—Indicates a higher bandwidth multiplying DAC, which is more suitable for signal generation. The multiplying bandwidth is specified as the reference-input frequency at which the gain is compressed by -3 dB.

Single-Channel to 8-Channel, Low Voltage Single-Supply V_{OUT} DACs

Resolution	Output Type	Interface	1-Channel Unbuffered	1-Channel		2-Channel		4-Channel		8-Channel		16-Channel
			Ext. Ref	Ext. Ref	Int. Ref	Ext. Ref	Int. Ref	Ext. Ref	Int. Ref	Ext. Ref	Int. Ref	
18-Bit	Unipolar Single Supply	SPI		■ AD5680 ^M								
	Unipolar Single Supply	SPI	■ LTC2641-16 ■ AD5541A ■ AD5062 ^M	■ AD5683 ■ AD5662 ^M ■ AD5060 ^M	■ AD5683R ■ AD5660 ^M	■ AD5689 ^M ■ AD5663 ^M ■ AD5065 ^M	■ AD5689R ^M ■ AD5663R ^M	■ AD5686 ^M ■ AD5664 ■ AD5064 ^M ■ LTC2604 ^M ■ AD5066 ^M	■ AD5686R ^M ■ AD5664R ■ LTC2654-16 ^M	■ AD5676 ^M ■ LTC2600	■ AD5676R ^M ■ AD5668 ^M ■ LTC2656-16 ^M ■ AD5678	■ AD5679R ■ AD5679
			Unipolar Single Supply	I ² C	■ AD5693 ■ LTC2606 ^M	■ AD5693R	■ AD5667 ■ LTC2607 ^M	■ AD5667R	■ AD5696 ^M ■ AD5665 ^M ■ LTC2609 ^M	■ AD5696R ^M ■ AD5665R ^M ■ LTC2655-16 ^M	■ AD5675 ^M ■ LTC2605 ^M	■ AD5675R ^M ■ AD5669R ^M ■ LTC2657-16 ^M
	Unipolar Single Supply	SPI	■ LTC2641-14 ■ AD5551	■ AD5040 ^M ■ AD5641 ■ LTC2611 ^M	■ AD5682R ■ AD5640 ^M	■ AD5045 ^M ■ LTC2612	■ AD5643R	■ AD5044 ^M ■ LTC2614 ^M	■ AD5685R ^M ■ AD5644R	■ LTC2610	■ AD5392 ■ AD5648 ^M	
			Unipolar Single Supply	I ² C	■ LTC2616 ^M	■ AD5692R	■ LTC2617 ^M	■ AD5647R	■ LTC2619 ^M	■ AD5695R ^M ■ AD5645R ^M	■ LTC2615 ^M	■ AD5392
	12-Bit	Unipolar Single Supply	PWM				■ LTC2644-12 ^Z		■ LTC2645-12 ^Z			
		Unipolar Single Supply	SPI	■ LTC2641-12 ■ AD5512A ^M	■ AD5621 ■ AD5320	■ AD5681R ■ LTC2630-12 ^M ■ LTC2640-12 ^M ■ AD5620 ^M	■ AD5687 ^M ■ AD5322 ■ AD5323 ■ LTC2622	■ AD5687R ^M ■ LTC2632-12 ^M ■ AD5623R	■ AD5684 ^M ■ AD5624 ■ AD5024 ^M ■ LTC2624 ^M	■ AD5684R ^M ■ AD5624R ■ LTC2654-12 ^M ■ LTC2634-12 ^M	■ LTC2620 ■ AD5328	■ AD5672 ^M ■ AD5628 ^M ■ LTC2656-12 ^M ■ LTC2636-12 ^M ■ AD5592R
				Unipolar Single Supply	I ² C	■ AD5622 ■ AD5321	■ AD5691R ■ LTC2631-12 ^M	■ AD5339 ■ AD5627 ■ LTC2627 ^M	■ LTC2633-12 ^Z ■ AD5627R ■ AD5697R ^M	■ AD5694 ^M ■ AD5326 ■ AD5325 ■ AD5625 ^M ■ LTC2629 ^M	■ AD5694R ^M ■ AD5625R ^M ■ LTC2655-12 ^M ■ LTC2635-12 ^Z	■ LTC2625 ^M
		Unipolar Single Supply	PWM					■ LTC2644-10 ^Z		■ LTC2645-10 ^Z		
	Unipolar Single Supply		SPI	■ AD5611 ■ AD5310	■ AD5310R ■ LTC2630-10 ^M ■ LTC2640-10 ^M	■ LTC1662 ■ AD5313 ■ AD5312	■ AD5313R ^M ■ LTC2632-10 ^M	■ AD5314 ■ LTC1664 ■ AD5317	■ AD5317R ^M ■ LTC2634-10 ^M	■ AD5318 ■ LTC1660	■ LTC2636-10 ^M	
				Unipolar Single Supply	I ² C	■ AD5612 ■ AD5311	■ AD5311R ■ LTC2631-10 ^M ■ LTC1669	■ AD5338	■ AD5338R ■ LTC2633-10 ^Z	■ AD5316 ■ AD5315	■ AD5316R ^M ■ LTC2635-10 ^Z	
	8-Bit	Unipolar Single Supply	PWM				■ LTC2644-8 ^Z		■ LTC2645-8 ^Z			
Unipolar Single Supply		SPI	■ AD5601 ■ AD5300	■ LTC2630-8 ^M ■ LTC2640-8 ^M	■ AD5302 ■ AD7303	■ LTC2632-8 ^M	■ AD5307 ■ AD5304	■ LTC2634-8 ^M	■ AD5308 ■ LTC1665	■ LTC2636-8 ^M		
			Unipolar Single Supply	I ² C	■ AD5602 ■ AD5301	■ LTC2631-8 ^M	■ AD5337	■ LTC2633-8 ^M	■ AD5306 ■ AD5305	■ LTC2635-8 ^M		■ LTC2637-8 ^M

■ Higher accuracy ■ Smaller solution ■ Lower glitch ^M Reset to mid-scale or zero-scale options
 ■ Lower power ■ ≥9 I²C addresses ■ ADC/DAC combo ^Z Reset to high-Z, midscale, or zero-scale
 ■ Suggested part

Precision DACs

Single-Channel to 8-Channel, Bipolar Voltage Output DACs

	Output Type	Interface	1-Channel Unbuffered	1-Channel		2-Channel		4-Channel		8-Channel		
			Ext. Ref	Ext. Ref	Int. Ref	Ext. Ref	Int. Ref	Ext. Ref	Int. Ref	Ext. Ref	Int. Ref	
Resolution	20-Bit	Bipolar	SPI	■ AD5790 ■ AD5791								
	18-Bit	Bipolar	SPI	■ AD5780 ■ AD5781								
	16-Bit	SoftSpan Bipolar	SPI		■ AD5761 ^M	■ AD5761R ^M	■ AD5752 ^M	■ AD5752R ^M	■ LTC2704-16 ■ AD5754 ^M	■ LTC2664-16 ^M ■ AD5754R ^M		■ LTC2666-16 ^M
		Bipolar	SPI	■ AD5760 ■ AD5570 ■ LTC2642-16 ■ AD5542A	■ AD5570 ■ AD7849		■ AD5763	■ AD5762R	■ AD5764 ■ AD5765	■ AD5764R	■ AD5362	
	14-Bit	SoftSpan Bipolar	SPI			■ AD5732 ^M	■ AD5732R ^M	■ AD5734 ^M ■ LTC2704-14	■ AD5734R ^M			
		Bipolar	SPI	■ LTC2642-14 ■ AD5552	■ AD5531			■ AD7834	■ AD5744R	■ AD5363		
	12-Bit	SoftSpan Bipolar	SPI		■ AD5721 ^M	■ AD5721R ^M	■ AD5722 ^M	■ AD5722R ^M	■ LTC2704-12 ■ AD5724 ^M	■ LTC2664-12 ^M ■ AD5724R ^M		■ LTC2666-12 ^M
		Bipolar	SPI	■ LTC2642-12 ■ AD5512A	■ AD5530			■ AD7249	■ AD5726 ■ AD7398			
	10-Bit	Bipolar ±5 V	SPI					■ AD7399				
	8-Bit	Bipolar ±5 V	SPI					■ AD7304				

- Suggested part
- Higher accuracy
- Lower glitch

^M Reset to mid-scale or zero-scale options

^Z Reset to high-Z, mid-scale, or zero-scale options

Precision DACs

AD5766/AD5767: 16-Channel, 16-/12-Bit Voltage Output *dense*DAC

Key Features

- ▶ Complete 16-channel, 12-bit digital-to-analog converter
- ▶ 4 mm × 4 mm WLCSP package
- ▶ Integrated DAC output buffers with ± 20 mA output current capability
- ▶ Integrated reference buffers
- ▶ Channel monitoring multiplexer
- ▶ 1.8 V logic compatibility
- ▶ Temperature range: -40°C to $+105^{\circ}\text{C}$

Benefits

- ▶ Ease of reuse with minor software changes required for different configurations
- ▶ This can be set at the design level or can be software configurable for users in final use applications
- ▶ Enhanced system capability allows shrinking size modules to maintain or increase their functionality
- ▶ Complete system biasing and control solution on a single chip

Applications

- ▶ Mach-Zehnder modulator bias control
- ▶ Optical modules
- ▶ Bias control
- ▶ Analog output modules

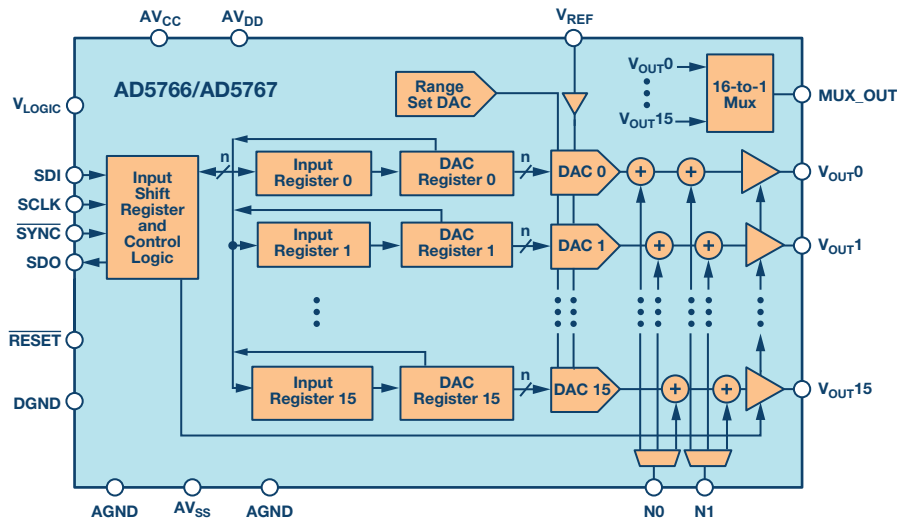

Precision DACs

16-Channel to 40-Channel Voltage Output DACs

Resolution	Output Type	Interface	16-Channel		32-Channel		40-Channel	
			Ext. Ref	Int. Ref	Ext. Ref	Int. Ref	Ext. Ref	Int. Ref
16-Bit	SoftSpan bipolar	SPI		■ LTC2668-16 ^M				
	Bipolar	SPI	■ AD5766 ■ AD5360		■ AD5372		■ AD5370	
	Unipolar single supply	SPI		■ LTC2668-16 ^M ■ AD5679R		■ AD5382		■ AD5384
14-Bit	Bipolar	SPI	■ AD5361		■ AD5373 ■ AD5378	■ AD5532B/ AD5532HS	■ AD5371 ■ AD5379	
	Unipolar single supply	SPI		■ AD5390		■ AD5382		■ AD5380
		I ² C			■ AD5390		■ AD5382	
12-Bit	SoftSpan bipolar	SPI		■ LTC2668-12 ^M				
	Bipolar	SPI	■ AD5767 ■ AD5516					
	Unipolar single supply	SPI		■ LTC2668-12 ^M ■ AD5674R ■ AD5391 ■ AD5590		■ AD5383		■ AD5381
		I ² C			■ AD5391		■ AD5383	

- Suggested part
- Lower power
- Smaller solution

^M Reset to midscale or zero-scale options

^Z Reset to high-Z, midscale, or zero-scale options

Parallel Interface Voltage Output DACs

Resolution	Output Type	Interface	1-Channel		2-Channel		4-Channel		8-Channel	32-Channel	40-Channel
			Ext. Ref	Int. Ref	Ext. Ref	Int. Ref	Ext. Ref	Int. Ref	Ext. Ref	Int. Ref	Int. Ref
16-Bit	Bipolar	Parallel	■ AD7846 ■ LTC1821								
	Unipolar single supply	Parallel		■ LTC1657							
14-Bit	Bipolar	Parallel					■ AD7835 ■ AD7836		■ AD7841	■ AD5378	
	Unipolar single supply	Parallel								■ AD5382	■ AD5380
12-Bit	Bipolar	Parallel			■ AD7847 ■ AD7837	■ AD7247 ■ AD7237	■ DAC8412 ■ DAC8413 ^M ■ AD5725 ^M				
	Unipolar single supply	Parallel	■ AD5340 ■ AD5341	■ LTC1450	■ AD5342 ■ AD5343		■ AD5344 ■ AD5725 ^M			■ AD5383	■ AD5381
10-Bit	Bipolar	Parallel					■ AD5583				
	Unipolar single supply	Parallel	■ AD5331		■ AD5333		■ AD5335 ■ AD5336		■ AD5347		
8-Bit	Bipolar	Parallel	■ AD7224				■ AD7225 ■ AD7226 ■ AD7305		■ AD7228		
	Unipolar single supply	Parallel	■ AD5330 ■ AD7801		■ AD5332 ■ AD7302		■ AD5334 ■ AD7305	■ AD7339	■ AD5346		

- Suggested part

^M Reset to midscale or zero-scale options

^Z Reset to high-Z, midscale, or zero-scale opti

Precision DACs

LTC2662: 5-Channel, 300 mA Current Source-Output, 16-Bit SoftSpan DAC

Key Features

- ▶ Per-channel programmable output ranges: 300 mA, 200 mA, 100 mA, 50 mA, 25 mA, 12.5 mA, 6.25 mA, and 3.125 mA
- ▶ Flexible 2.85 V to 33 V supply voltage
- ▶ 1 V dropout guaranteed
- ▶ Separate voltage supply per output channel
- ▶ Internal switches to optional negative supply
- ▶ Full 16-bit resolution at all ranges
- ▶ Guaranteed operation -40°C to $+125^{\circ}\text{C}$
- ▶ Precision (10 ppm/ $^{\circ}\text{C}$ max) internal reference or external reference input
- ▶ Analog mux monitors voltages and currents
- ▶ A/B toggle via SPI or dedicated pin
- ▶ 1.8 V to 5 V SPI serial interface
- ▶ 5 mm \times 5 mm, 32-lead QFN package

Applications

- ▶ Tunable lasers
- ▶ Semiconductor optical amplifiers
- ▶ Resistive heaters
- ▶ Current-mode biasing
- ▶ Proportional solenoid drive

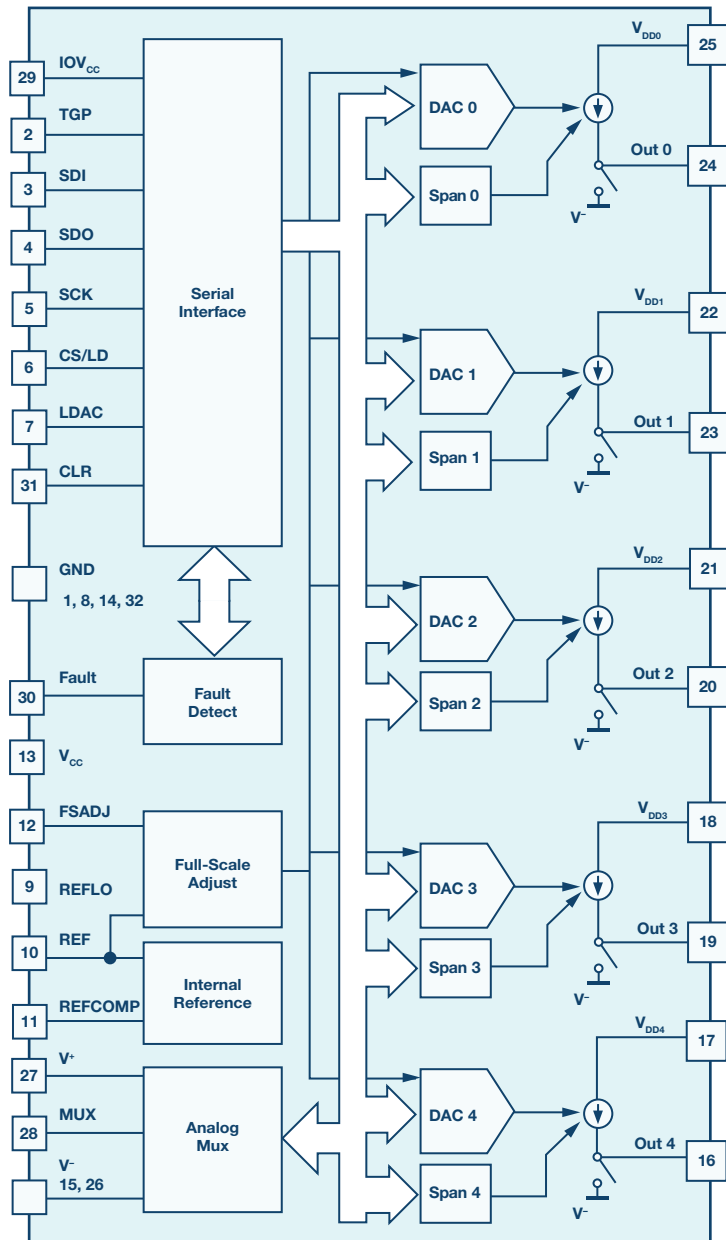

Precision DACs

Multiplying (I_{OUT}) DACs

		Output Type	Interface	1-Channel	2-Channel	4-Channel	8-Channel
Resolution	18-Bit	SoftSpan bipolar	SPI	■ LTC2756	■ LTC2758		
			Parallel	■ LTC2757			
	16-Bit	SoftSpan bipolar	SPI	■ LTC1592	■ LTC2752	■ LTC2754-16	
			Parallel	■ LTC2751-16	■ LTC2753-16	■ LTC2755-16	
		Bipolar	SPI	■ AD5543 ■ LTC1596 ^M ■ LTC1595	■ AD5545 ^M	■ AD5544 ^M	
			Parallel	■ AD5546 ^M ■ LTC1597 ^M	■ AD5547 ^M		
	14-Bit	SoftSpan bipolar	SPI	■ LTC1589			
			Parallel	■ LTC2751-14	■ LTC2753-14	■ LTC2755-14	
		Bipolar	SPI	■ AD5453 ■ AD5553 ■ AD5446	■ AD5555 ^M	■ AD5554 ^M	
			Parallel	■ LTC1591 ^M ■ AD5556 ^M	■ AD5557 ^M		
			SPI	■ LTC1588		■ LTC2754-12	
		12-Bit	SoftSpan bipolar	Parallel	■ LTC2751-12	■ LTC2753-12	■ LTC2755-12
	Bipolar			SPI	■ AD5441 ■ AD5443 ■ AD5444 ■ AD5452	■ LTC1590 ■ AD5415 ■ AD5449	
		10-Bit	Bipolar	Parallel	■ AD5445	■ AD5405 ■ AD5447	
				SPI	■ AD5451 ■ AD5432	■ AD5439	■ AD7564
		8-Bit	Bipolar	Parallel	■ AD5433	■ AD5440	
				SPI	■ AD5450 ■ AD5425 ■ AD5426	■ AD5429	
				Parallel	■ AD5424	■ AD5428	

■ Suggested part

■ >5 MHz bandwidth

^M Reset to midscale or zero-scale options

Special Function DACs

4 mA to 20 mA Loop DACs

		Current Output Range	Interface	Voltage Output Range	1-Channel	4-Channel
Resolution	16-Bit	4 mA to 20 mA, 0 mA to 20 mA, 0 mA to 24 mA	SPI	None	■ AD5420 ■ AD5421	
				0 V to 5 V, 0 to 10 V, ±5 V, ±10 V	■ AD5422	
		4 mA to 20 mA			■ AD5755-1	
	12-Bit	4 mA to 20 mA, 0 mA to 20 mA, 0 mA to 24 mA	SPI	None	■ AD5410	
				0 V to 5 V, 0 V to 10 V, ±5 V, ±10 V	■ AD5412	
		4 mA to 20 mA				

■ Suggested part

■ Loop powered

■ Dynamic power control

Precision DACs

High Voltage DACs

		Voltage Output Range	Interface	1-Channel	4-Channel	32-Channel
Resolution	14-Bit	50 V to 200 V	SPI			■ AD5535B
	12-Bit	30 V or 60 V	SPI	■ AD5501	■ AD5504	

■ Suggested part

Fast Precision DACs (>30 MSPS)

		Output Type	Interface	1-Channel	
				Part Number	Speed
Resolution	16-Bit	Current steering	Parallel	■ LTC1668	50 MSPS
	14-Bit	Current steering	Parallel	■ LTC1667	50 MSPS
	12-Bit	Current steering	Parallel	■ LTC1666	50 MSPS

■ Suggested part

Micropower Voltage Output DACs

		Interface	1-Channel		2-Channel			4-Channel		8-Channel		
				I _o (3 V)	Ext. Ref	I _o (3 V)	Int. Ref	I _o (3 V)	Ext. Ref	I _o (3 V)	Ext. Ref	I _o (3 V)
Resolution	14-Bit	SPI	■ AD5641	60 μA								
	12-Bit	Parallel	■ AD5340 ■ AD5341	115 μA								
	10-Bit	SPI			■ LTC1662	3 μA			■ LTC1664	186 μA	■ LTC1660	340 μA
					■ LTC1661	95 μA						
		I ² C					■ LTC1669	60 μA				
	SMBus					■ LTC1663	60 μA					
	Parallel	■ AD5331	115 μA									
	8-Bit	SPI									■ LTC1665	340 μA
Parallel		■ AD5330	115 μA									

■ Suggested part

Current Source-Sink DACs

		Interface	Channels	Current Sink		Current Source	
				Part Number	Output Range	Part Number	Output Ranges
Resolution	16-Bit	SPI	5			■ LTC2662-16 <i>New</i> ■ LTC2652-16 <i>Coming Soon</i>	Software selectable all channels: 3.125 mA, 6.25 mA, 12.5 mA, 25 mA, 50 mA, 100 mA, 200 mA, 300 mA
	14-Bit	SPI	6			■ AD5770R <i>New</i>	Software selectable all channels: 3.125 mA, 6.25 mA, 12.5 mA, 25 mA, 50 mA, 100 mA, 200 mA, 300 mA, and a switch to V _{ss} to sink current
	12-Bit	SPI	5			■ LTC2662-12 <i>New</i> ■ LTC2652-12 <i>Coming Soon</i>	Software selectable all channels: 3.125 mA, 6.25 mA, 12.5 mA, 25 mA, 50 mA, 100 mA, 200 mA, 300 mA
	10-Bit	I ² C	1	■ AD5398A ■ AD5821A	3 mA to 120 mA		

■ Suggested part

■ Lower power

Precision DACs

ADC/DAC Combos

Resolution	Output Type	Interface	4-Channel		8-Channel		16-Channel	
			Part Number	# of ADC Channels	Part Number	# of ADC Channels	Part Number	# of ADC Channels
12-Bit	Bipolar	SPI			■ AD7293	4		
	Unipolar single supply	SPI			■ AD5592R	8	■ AD5590	16
		I ² C	■ AD7294-2	2	■ AD5593R	8		
			■ AD7294	4				
	SPI/I ² C	■ AD7517	4					
10-Bit	Unipolar single supply	SPI	■ AD7292	8				
		SPI/I ² C	■ AD7516	4				

■ Suggested part

PWM to Voltage Output DACs

Resolution	Voltage Output Range	Interface	2-Channel		4-Channel	
			Part Number	# of ADC Channels	Part Number	# of ADC Channels
12-Bit	0 V to 5 V	PWM	■ LTC2644-12		■ LTC2645-12	
10-Bit	0 V to 5 V	PWM	■ LTC2644-10		■ LTC2645-10	
8-Bit	0 V to 5 V	PWM	■ LTC2644-8		■ LTC2645-8	

■ Suggested part

Digital Potentiometers

Nonvolatile Memory

Part Number	Resolution (Number of Wiper Steps)	Number of Channels	Maximum Terminal Voltage Range (V)	Interface	Nominal Resistance (k Ω)	Absolute Tempco (ppm/ $^{\circ}$ C)	Package	Comments	ECCN Code
<i>One Time Programmable (OTP) Memory</i>									
AD5273	64	1	5.5	I ² C	1, 10, 50, 100	300	8-lead SOT-23	1 k Ω option has high bandwidth	EAR99
AD5171	64	1	5.5	I ² C	5, 10, 50, 100	35	8-lead SOT-23	Tempco is 5 ppm/ $^{\circ}$ C in potentiometer mode	EAR99
AD5172	256	2	5.5	I ² C	2.5, 10, 50, 100	35	10-lead MSOP	Tempco is 15 ppm/ $^{\circ}$ C in potentiometer mode	EAR99
AD5173	256	2	5.5	I ² C	2.5, 10, 50, 100	35	10-lead MSOP	Additional address pins (ADO and AD1)	EAR99
<i>Multitime Programmable (MTP) Memory</i>									
AD5271	256	1	\pm 2.75, 5.5	SPI	20, 100	35	10-lead LFCSP, 10-lead MSOP	1% R-tolerance, 50 TP,† internal fuse programming supply	EAR99
AD5291	256	1	\pm 16.5, 33	SPI	20, 50, 100	35	14-lead TSSOP	High voltage, 1% R-tolerance, 20 TP,† internal fuse programming supply, low THD	EAR99
AD5170	256	1	5.5	I ² C	2.5, 10, 50, 100	35	10-lead MSOP	2 TP†	EAR99
AD5274	256	1	\pm 2.75, 5.5	I ² C	20, 100	35	10-lead LFCSP, 10-lead MSOP	1% R-tolerance, 50 TP,† internal fuse programming supply	EAR99
AD5270	1024	1	\pm 2.75, 5.5	SPI	20, 50, 100	35	10-lead LFCSP, 10-lead MSOP	1% R-tolerance, 50 TP,† internal fuse programming supply	EAR99
AD5174	1024	1	\pm 2.75, 5.5	SPI	10	35	10-lead LFCSP, 10-lead MSOP	50 TP,† internal fuse programming supply	EAR99
AD5292	1024	1	\pm 16.5, 33	SPI	20, 50, 100	35	14-lead TSSOP	High voltage, 1% R-tolerance, 20 TP,† internal fuse programming supply, low THD	EAR99
AD5272	1024	1	\pm 2.75, 5.5	I ² C	20, 50, 100	35	10-lead LFCSP, 10-lead MSOP	1% R-tolerance, 50 TP,† internal fuse programming supply	EAR99
AD5175	1024	1	\pm 2.75, 5.5	I ² C	10	35	10-lead LFCSP, 10-lead MSOP	50 TP,† internal fuse programming supply	EAR99
<i>EEPROM</i>									
AD5114	32	1	5.5	I ² C	10, 80	35	8-lead LFCSP	8% R-tolerance; 2.3 V _{SUPPLY} operation, low power consumption	EAR99
AD5115	32	1	5.5	Up/down	10, 80	35	8-lead LFCSP	8% R-tolerance; 2.3 V _{SUPPLY} operation, low power consumption	EAR99
AD5112	64	1	5.5	I ² C	5, 10, 80	35	8-lead LFCSP	8% R-tolerance; 2.3 V _{SUPPLY} operation, low power consumption	EAR99
AD5113	64	1	5.5	Up/down	5, 10, 80	35	8-lead LFCSP	8% R-tolerance; tempco is 5 ppm/ $^{\circ}$ C in potentiometer mode	EAR99
AD5116	64	1	5.5	Push-button	5, 10, 80	35	8-lead LFCSP	8% R-tolerance; 2.3 V _{SUPPLY} operation, low power consumption	EAR99
AD5258	64	1	5.5	I ² C	1, 10, 50, 100	300	10-lead MSOP	% R-tolerance error stored in NVM	EAR99
AD5110	128	1	5.5	I ² C	10, 80	35	8-lead LFCSP	8% R-tolerance; 2.3 V _{SUPPLY} operation, low power consumption	EAR99
AD5111	128	1	5.5	Up/down	10, 80	35	8-lead LFCSP	8% R-tolerance; 2.3 V _{SUPPLY} operation, low power consumption	EAR99
AD5121	128	1	\pm 2.75, 5.5	SPI/I ² C	10, 100	35	16-lead LFCSP	LGST,* 8% R-tolerance; 2.3 V _{SUPPLY} operation	EAR99
AD5259	256	1	5.5	I ² C	5, 10, 50, 100	300	10-lead LFCSP, 10-lead MSOP	% R-tolerance error stored in NVM	EAR99
AD5141	256	1	\pm 2.75, 5.5	SPI/I ² C	10, 100	35	16-lead LFCSP	LGST,* 8% R-tolerance; 2.3 V _{SUPPLY} operation	EAR99
AD5231	1024	1	\pm 2.75, 5.5	SPI	10, 50, 100	600	16-lead TSSOP	28 bytes of user-programmable NVM	EAR99
AD5251	64	2	\pm 2.75, 5.5	I ² C	1, 10, 50, 100	600	14-lead TSSOP	% R-tolerance error stored in NVM, 12 bytes of user-programmable NVM	EAR99
AD5122A	128	2	\pm 2.75, 5.5	I ² C	10, 100	35	16-lead LFCSP, 16-lead TSSOP	LGST,* 8% R-tolerance; 2.3 V _{SUPPLY} operation	EAR99
AD5122	128	2	\pm 2.75, 5.5	SPI	10, 100	35	16-lead LFCSP, 16-lead TSSOP	LGST,* 8% R-tolerance; 2.3 V _{SUPPLY} operation	EAR99
AD5232	256	2	\pm 2.75, 5.5	SPI	10, 50, 100	300	16-lead TSSOP	14 bytes of user-programmable NVM	EAR99
AD5252	256	2	\pm 2.75, 5.5	I ² C	1, 10, 50, 100	300	14-lead TSSOP	% R-tolerance error stored in NVM, 12 bytes of user-programmable NVM	EAR99
AD5142A	256	2	\pm 2.75, 5.5	I ² C	10, 100	35	16-lead LFCSP, 16-lead TSSOP	LGST,* 8% R-tolerance; 2.3 V _{SUPPLY} operation	EAR99
AD5142	256	2	\pm 2.75, 5.5	SPI	10, 100	35	16-lead LFCSP, 16-lead TSSOP	LGST,* 8% R-tolerance; 2.3 V _{SUPPLY} operation	EAR99
AD5235	1024	2	\pm 2.75, 5.5	SPI	25, 250	35	16-lead TSSOP	% R-tolerance error stored in NVM, 26 bytes of user-programmable NVM	EAR99
ADN2850	1024	2	\pm 2.75, 5.5	SPI	25, 250	35	16-lead LFCSP, 16-lead TSSOP	% R-tolerance error stored in NVM, 26 bytes of user-programmable NVM	EAR99
AD5233	64	4	\pm 2.75, 5.5	SPI	10, 50, 100	600	24-lead TSSOP	11 bytes of user-programmable NVM	EAR99

† TP = times programmable

*Linear gain setting mode

Digital Potentiometers

Nonvolatile Memory (Continued)

Part Number	Resolution (Number of Wiper Steps)	Number of Channels	Maximum Terminal Voltage Range (V)	Interface	Nominal Resistance (k Ω)	Absolute Tempco (ppm/ $^{\circ}$ C)	Package	Comments	ECCN Code
AD5253	64	4	\pm 2.75, 5.5	I ² C	1, 10, 50, 100	300	20-lead TSSOP	% R-tolerance error stored in NVM, 12 bytes of user-programmable NVM	EAR99
AD5123	128	4	\pm 2.75, 5.5	I ² C	10, 100	35	16-lead LFCSP	LGST,* 8% R-tolerance; 2.3 V _{SUPPLY} operation	EAR99
AD5124	128	4	\pm 2.75, 5.5	SPI/I ² C	10, 100	35	24-lead LFCSP, 20-lead TSSOP	LGST,* 8% R-tolerance; 2.3 V _{SUPPLY} operation	EAR99
AD5254	256	4	\pm 2.75, 5.5	I ² C	1, 10, 50, 100	300	20-lead TSSOP	% R-tolerance error stored in NVM, 12 bytes of user-programmable NVM	EAR99
AD5143	256	4	\pm 2.75, 5.5	I ² C	10, 100	35	16-lead LFCSP	LGST,* 8% R-tolerance; 2.3 V _{SUPPLY} operation	EAR99
AD5144A	256	4	\pm 2.75, 5.5	I ² C	10, 100	35	20-lead TSSOP	LGST,* 8% R-tolerance; 2.3 V _{SUPPLY} operation	EAR99
AD5144	256	4	\pm 2.75, 5.5	SPI/I ² C	10, 100	35	24-lead LFCSP, 20-lead TSSOP	LGST,* 8% R-tolerance; 2.3 V _{SUPPLY} operation	EAR99

† TP = times programmable

*Linear gain setting mode

Volatile Digital Potentiometers

Part Number	Resolution (Number of Wiper Steps)	Number of Channels	Maximum Terminal Voltage Range (V)	Interface	Nominal Resistance (k Ω)	Absolute Tempco (ppm/ $^{\circ}$ C)	Package	Comments	ECCN Code
AD5228	32	1	5.5	Push-button	10, 50, 100	35	8-lead TSOT	Manual with built-in debouncer	EAR99
AD5201	33	1	\pm 2.75, 5.5	SPI	10, 50	500	10-lead MSOP	Low wiper resistance	EAR99
AD5227	64	1	5.5	Up/down	10, 50, 100	35	8-lead TSOT	Tempco is 10 ppm/ $^{\circ}$ C in potentiometer mode	EAR99
AD5246	128	1	5.5	I ² C	5, 10, 50, 100	35	6-lead SC70	Ultracompact, rheostat only	EAR99
AD5247	128	1	5.5	I ² C	5, 10, 50, 100	35	6-lead SC70	Ultracompact	EAR99
AD5220	128	1	5.5	Up/down	10, 50, 100	800	8-lead MSOP, 8-lead SOIC		EAR99
AD7376	128	1	\pm 16.5, 33	SPI	10, 50, 100	300	14-lead TSSOP, 16-lead SOIC	High voltage	EAR99
AD5160	256	1	5.5	SPI	5, 10, 50, 100	35	8-lead SOT-23		EAR99
AD5165	256	1	5.5	SPI	100	35	8-lead TSOT	Low power: 0.05 μ A	EAR99
AD5245	256	1	5.5	I ² C	5, 10, 50, 100	35	8-lead SOT-23		EAR99
AD5161	256	1	5.5	SPI	5, 10, 50, 100	35	10-lead MSOP		EAR99
AD5241	256	1	\pm 2.75, 5.5	I ² C	10, 100, 1000	30	14-lead TSSOP, 14-lead SOIC		EAR99
AD5200	256	1	\pm 2.75, 5.5	SPI	10, 50	500	10-lead MSOP		EAR99
AD8400	256	1	5.5	SPI	1, 10, 50, 100	500	8-lead SOIC	1 k Ω option has high bandwidth	EAR99
AD5260	256	1	\pm 5.5, 16.5	SPI	20, 50, 200	35	14-lead TSSOP		EAR99
AD5280	256	1	\pm 5.5, 16.5	I ² C	20, 50, 200	35	14-lead TSSOP		EAR99
AD5290	256	1	\pm 16.5, 33	SPI	10, 50, 100	35	10-lead MSOP	High voltage	EAR99
AD5293	1024	1	\pm 16.5, 33	SPI	20, 50, 100	35	14-lead TSSOP	High voltage, 1% R-tolerance, low THD	EAR99
AD5222	128	2	\pm 2.75, 5.5	Up/down	10, 50, 100, 1000	35	14-lead TSSOP, 14-lead SOIC		EAR99
AD5162	256	2	5.5	SPI	2.5, 10, 50, 100	35	10-lead MSOP	Rheostat/potentiometer	EAR99
AD5207	256	2	\pm 2.75, 5.5	SPI	10, 50, 100	500	14-lead TSSOP	AD8402 replacement	EAR99
AD8402	256	2	5.5	SPI	1, 10, 50, 100	500	14-lead TSSOP, 14-lead SOIC	1 k Ω option has high bandwidth	EAR99
AD5262	256	2	\pm 5.5, 16.5	SPI	20, 50, 200	35	16-lead TSSOP		EAR99
AD5243	256	2	5.5	I ² C	2.5, 10, 50, 100	35	10-lead MSOP	Rheostat/potentiometer	EAR99
AD5248	256	2	5.5	I ² C	2.5, 10, 50, 100	35	10-lead MSOP	Rheostat only	EAR99
AD5242	256	2	\pm 2.75, 5.5	I ² C	10, 100, 1000	30	16-lead TSSOP, 16-lead SOIC		EAR99
AD5282	256	2	\pm 5.5, 16.5	I ² C	20, 50, 200	35	16-lead TSSOP		EAR99
AD5203	64	4	5.5	SPI	10, 100	700	24-lead TSSOP, 24-lead SOIC		EAR99
AD5204	256	4	\pm 2.75, 5.5	SPI	10, 50, 100	700	32-lead LFCSP, 24-lead TSSOP, 24-lead SOIC	Preset to midscale/zero-scale pin	EAR99
AD8403	256	4	5.5	SPI	1, 10, 50, 100	500	24-lead TSSOP, 24-lead SOIC	1 k Ω option has high bandwidth	EAR99
AD5263	256	4	\pm 7.5, 16.5	SPI/I ² C	20, 50, 200	30	24-lead TSSOP	Additional I ² C address pins (AD0 and AD1)	EAR99
AD5206	256	6	\pm 2.75, 5.5	SPI	10, 50, 100	700	24-lead TSSOP, 24-lead SOIC	Preset to midscale/zero-scale pin	EAR99

Voltage References

ADR365W: Low Power, Low Noise Voltage Reference with Source/Sink Capability

Key Features

- ▶ First automotive grade 0 V reference on the market
- ▶ Automotive grade 0 (–40°C to +150°C)
- ▶ Automotive grade 1 (–40°C to +125°C)
- ▶ 25 ppm/°C max for both grade 0 and grade 1 models
- ▶ No external capacitor required
- ▶ Compact 5-lead TSOT package

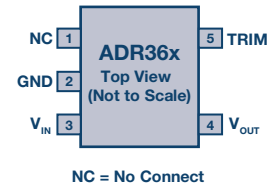

Benefits

- ▶ Low dropout: 300 mV
- ▶ Up to 15 V supply with +5 mA/–1 mA output current capability
- ▶ Only 190 μ A supply current max (150°C)
- ▶ TRIM pin to allow user to fine trim the output
- ▶ Also available with 3.3 V (grade 0, ADR366W)

Applications

- ▶ Engine management applications (on engine/in transmission)
- ▶ Exhaust system applications (sensing)

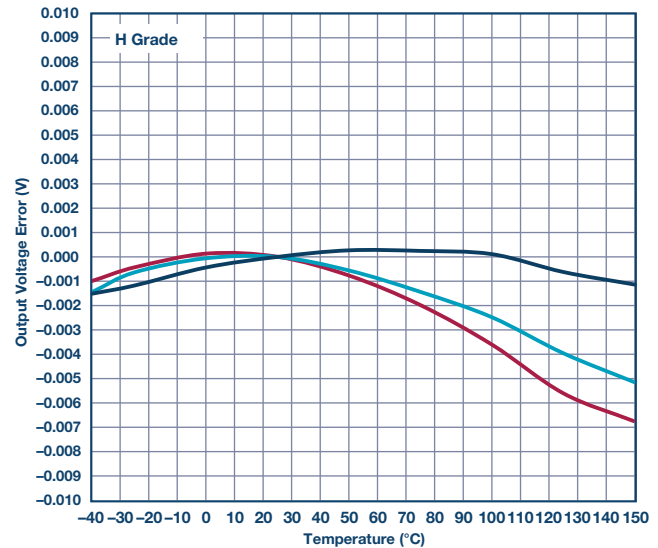

High Stability Voltage References

Part Number	Output Voltage (V)	Tempco (ppm/°C) (max)	Initial Accuracy (%) (max)	Supply Voltage Range (V)	ISY (max)	Output Current Source/Sink (mA)	0.1 Hz to 10 Hz Noise		Temperature Range (°C)	Type	Package	ECCN Code
							μ V p-p	ppm p-p				
LTZ1000	7	0.05	0.04				1.2	0.17	–55°C to +125°C	Shunt	TO-5	EAR99
LM399A	7	1, 2	0.05				10	1.4	0°C to 70°C	Shunt	TO-46	EAR99
ADR4525 <i>New</i>	2.5	1	0.02, 0.04	3.0 to 15	950 μ A	–10 to +10	1.25	0.6	0°C to 70°C	Series	SOIC	EAR99
LT6657 <i>New</i>	1.25, 2.048, 2.5, 3, 3.3, 4.096, 5	1.5, 3	0.1	1.3 to 40	1.2 mA	\pm 10		0.5	–40°C to +125°C	Series	8-lead MSOP	EAR99
AD588	\pm 5, \pm 10	1.5, 3	0.01, 0.02, 0.03, 0.05, 0.06, 0.1	\pm 18	10 mA	–10 to +10	6		–55°C to +125°C	Series	SOIC	EAR99
LTC6655	1.25, 2.048, 2.5, 3, 3.3, 4.096, 5	2, 5	0.025, 0.05	3.0 to 13.2	5 mA	\pm 10		0.25	–40°C to +125°C	Series	8-lead MSOP, 8-lead LS	EAR99
LTC6655LN <i>New</i>	1.25, 2.048, 2.5, 3, 3.3, 4.096, 5	2, 5	0.025, 0.05	3.0 to 13.2	5 mA	\pm 10		0.25	–40°C to +125°C	Series	8-lead MSOP, 8-lead LS	EAR99
LT1027	5	2, 3, 5, 7.5	0.05, 0.1	8 to 40	3.1 mA	–10 to +15		0.6	–40°C to +85°C	Series	8-lead DIP	EAR99
ADR4520	2.048	2, 4	0.02, 0.04	3.0 to 15	950 μ A	–10 to +10	1.25	0.6	–40°C to +125°C	Series	SOIC	EAR99
ADR4525	2.5	2, 4	0.02, 0.04	3.0 to 15	950 μ A	–10 to +10	1.25	0.6	–40°C to +125°C	Series	SOIC	EAR99

Voltage References

High Stability Voltage References (Continued)

Part Number	Output Voltage (V)	Tempco (ppm/°C) (max)	Initial Accuracy (%) (max)	Supply Voltage Range (V)	ISY (max)	Output Current Source/Sink (mA)	0.1 Hz to 10 Hz Noise		Temperature Range (°C)	Type	Package	ECCN Code
							µV p-p	ppm p-p				
ADR4530	3	2, 4	0.02, 0.04	3.1 to 15	950 µA	-10 to +10	1.6	0.6	-40°C to +125°C	Series	SOIC	EAR99
ADR4533	3.3	2, 4	0.02, 0.04	3.4 to 15	950 µA	-10 to +10	2.1	0.6	-40°C to +125°C	Series	SOIC	EAR99
ADR4540	4.096	2, 4	0.02, 0.04	4.2 to 15	950 µA	-10 to +10	2.7	0.6	-40°C to +125°C	Series	SOIC	EAR99
ADR4550	5	2, 4	0.02, 0.04	5.1 to 15	950 µA	-10 to +10	2.8	0.6	-40°C to +125°C	Series	SOIC	EAR99
AD586	5	2, 5, 10	0.04	10.8 to 36	3 mA	-5 to +10	4	0.8	-55°C to +125°C	Series	SOIC	EAR99
AD780	2.5	3, 7	0.04, 0.2	4.0 to 36	1 mA	±10	4	1.6	-40°C to +85°C	Series	SOIC	EAR99
AD688	±10	3, 8	0.015, 0.03	±13.5 to 18	12 mA	+10, -10	6		-55°C to +125°C	Series	SOIC	EAR99
LT1031	10	5, 15, 25	0.05, 0.1, 0.2	11 to 40	1.7 mA	±10	6	0.6	-55°C to +125°C	Series	TO-39	EAR99
LT1021	5, 7, 10	5, 20	0.05, 1	7.2 to 40	1.2 mA	±10		0.6	-55°C to +125°C	Series	TO-5, 8-lead DIP	EAR99

LT6657: 1.5 ppm/°C Drift, Low Noise, Buffered Reference

Key Features

- ▶ Wide supply range to 40 V and low dropout voltage of just 50 mV allow for use in a broad range of applications
- ▶ Fully specified from -40°C to +125°C
- ▶ 1.25 V, 2.5 V, 3 V, 4.096 V, 5 V voltage options available in 8-lead MSOP package

Benefits

- ▶ Positive or negative voltage output configurations allow for this product to be used in a wider range of applications
- ▶ Positive or negative shunt configuration and a shutdown pin increase this products flexibility and suitable to replace existing products
- ▶ Current sink and source capability of ±10 mA simplifies circuit design and makes this product easy to use

Applications

- ▶ High temperature industrial
- ▶ High resolution data acquisition systems
- ▶ Instrumentation and process control
- ▶ Automotive control and monitoring
- ▶ Medical equipment
- ▶ Shunt and negative voltage references

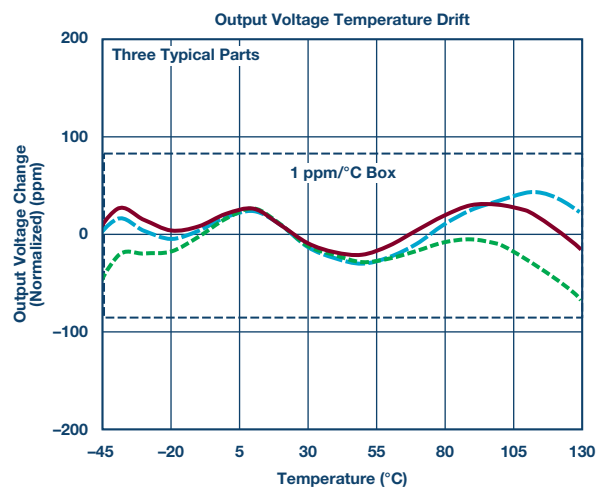

Initial Accuracy (%) (Max)	Supply Voltage Range (V)	ISY (mA) (max)	Tempco (ppm/°C) (max)	Output Current Source/Sink (mA)	0.1 Hz to 10 Hz Noise ppm p-p
0.1	1.3 to 40	1.2	1.5	±10	0.5

Voltage References

Automotive Qualified References

Part Number	Output Voltage (V)	Initial Accuracy (%) (max)	Supply Voltage Range (V)	ISY (max)	Tempco (ppm/°C) (max)	Output Current Source/Sink (mA)	0.1 Hz to 10 Hz Noise		Temperature Range (°C)	Type	Package	ECCN Code
							µV p-p	ppm p-p				
LT6657 New	1.25, 2.048, 2.5, 3, 3.3, 4.096, 5	0.1	1.3 to 40	1.2 mA	1.5, 3	±10		0.5	-40°C to +125°C	Series	MS-8	EAR99
ADR4525 New	2.5	0.02	3.0 to 15	950 µA	2	-10 to +10	1.25	0.6	-40°C to +125°C	Series	SOIC	EAR99
ADR3512 New	1.2	0.1	2.3 to 5.5	100 µA	4, 8	-3 to +10	8	6.7	-40°C to +125°C	Series	MSOP	EAR99
ADR3525 New	2.5	0.1	2.7 to 5.5	100 µA	5, 8	-3 to +10	18	7.2	-40°C to +125°C	Series	MSOP	EAR99
ADR3530 New	3	0.1	3.2 to 5.5	100 µA	5, 8	-3 to +10	22	7.3	-40°C to +125°C	Series	MSOP	EAR99
ADR3533 New	3.3	0.1	3.5 to 5.5	100 µA	5, 8	-3 to +10	25	7.6	-40°C to +125°C	Series	MSOP	EAR99
ADR3540 New	4.096	0.1	4.3 to 5.5	100 µA	5, 8	-3 to +10	29	7.1	-40°C to +125°C	Series	MSOP	EAR99
ADR3550 New	5	0.1	5.2 to 5.5	100 µA	5, 8	-3 to +10	35	7.0	-40°C to +125°C	Series	MSOP	EAR99
ADR03	2.5	0.2	4.5 to 36	1 mA	10	10	6	2.4	-40°C to +125°C	Series	SOIC	EAR99
ADR06	3	0.2	5.0 to 36	1 mA	10	10	10	3.3	-40°C to +125°C	Series	SOIC	EAR99
ADR02	5	0.1	7.0 to 36	1 mA	10	10	10	2.0	-40°C to +125°C	Series	SOIC	EAR99
ADR01	10	0.14	12 to 36	1 mA	10	10	20	2.0	-40°C to +125°C	Series	SOIC	EAR99
LT1461	2.5, 3, 3.3, 4.096, 5	0.04, 0.06, 0.08, 0.15	2.8 to 20	50 µA	3, 7, 12, 20	50		8.0	-40°C to +125°C	Series	8-lead SO	EAR99
ADR366	3.3	0.25	3.6 to 15	190 µA	25	-1 to +5	9.3	2.8	-40°C to +125°C	Series	SOT-23	EAR99
ADR365	5	0.16	5.3 to 15	190 µA	25	-1 to +5	12.8	2.6	-40°C to +125°C	Series	SOT-23	EAR99
ADR365 (H-grade) New	5	0.16	5.3 to 15	190 µA	25	-1 to +5	12.8	2.6	-40°C to +150°C	Series	SOT-23	EAR99
LT6654 New	1.25, 2.048, 2.5, 3, 3.3, 4.096, 5	0.05, 0.1	1.75 to 36	350 µA	10, 20	±10		1.6	-40°C to +125°C	Series	SOT-23	EAR99
ADR291	2.5	0.332	3.0 to 15	15 µA	15	5	8	3.2	-40°C to +125°C	Series	SOIC	EAR99
AD1582	2.5	0.08, 0.8	2.7 to 12	70 µA	50, 100	±5	70	28.0	-40°C to +125°C	Series	SOT-23	EAR99
AD1583	3	0.1, 1.0	3.2 to 12	70 µA	50, 100	±5	85	28.3	-40°C to +125°C	Series	SOT-23	EAR99
ADR512	1.2	0.3			60	0.3	4	3.3	-40°C to +85°C	Shunt	SOT-23	EAR99
ADR5041 New	2.5	0.1, 0.2			75, 100		19.2	7.7	-40°C to +125°C	Shunt	SOT-23	EAR99
ADR5044 New	4.096	0.1, 0.2			75, 100		32.2	7.9	-40°C to +125°C	Shunt	SOT-23	EAR99

Voltage References

LT6658: Precision, Dual Output, High Current, Low Noise, Voltage Reference

Key Features

- ▶ Reference and regulator combined in a single package with dual tracking and Kelvin sensed outputs
- ▶ Available with 1.2 V, 1.8 V, 2.5 V, 3 V, 3.3 V, or 5 V default output voltage
- ▶ 150 mA and 50 mA output for combined 200 mA total output current

Applications

- ▶ Microcontroller or FPGA with ADC/DAC applications
- ▶ Data acquisition systems
- ▶ Automotive control and monitoring
- ▶ Precision low noise regulators
- ▶ Instrumentation and process control

Benefits

- ▶ Simplifies system design by combining two functions in one saving area and cost while increasing system reliability
- ▶ Kelvin sense improves load regulation but adds flexibility making all output voltage options adjustable with external resistors
- ▶ Separate supply pins for each output allows for building an output stage with 150 dB PSRR (see data sheet for circuit)

Initial Accuracy (%) (max)	Supply Voltage Range (V)	I_{S_Y} (mA) (max)	Tempco (ppm/°C) (max)	Output Current Source/ Sink (mA)	0.1 Hz to 10 Hz Noise ppm p-p
0.1	3.5 to 36	2.5	10	+150/-20 mA and +50 mA/-20 mA	2.2

Providing a Precision Reference and Supply Voltage to a Mixed-Signal Application

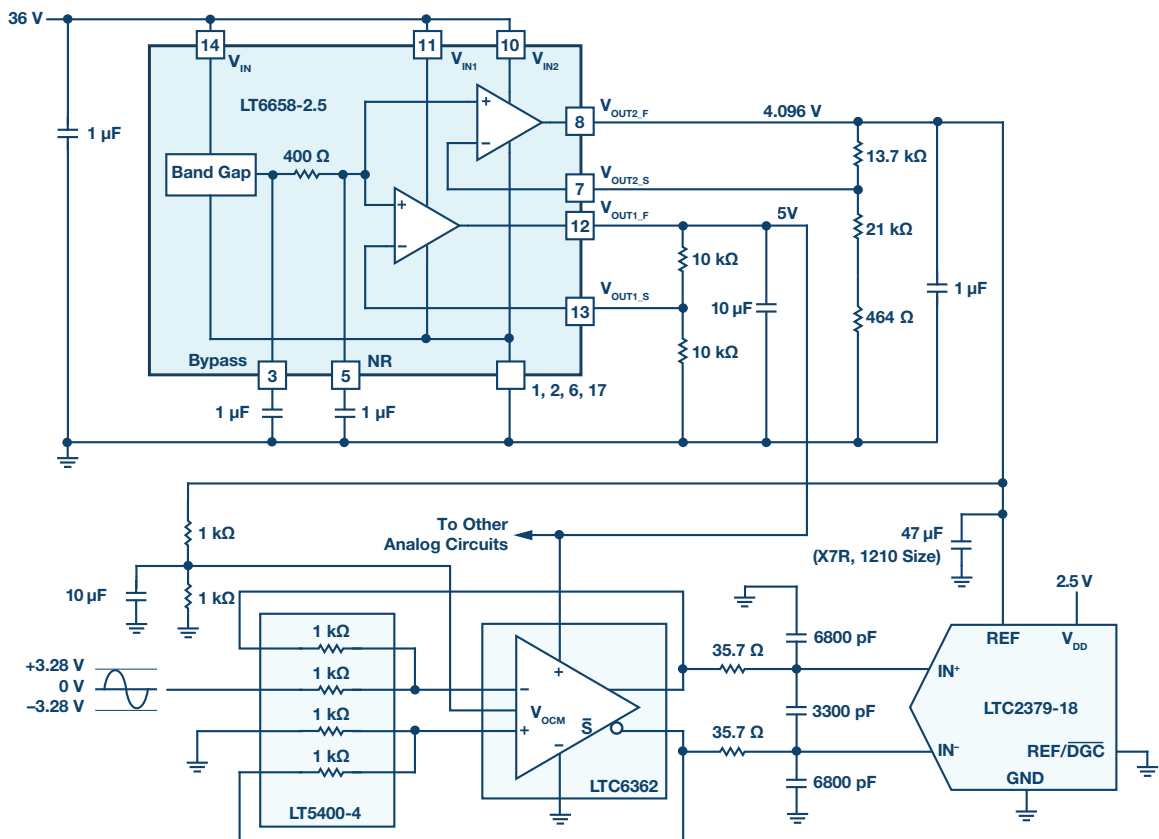

Voltage References

High Output Current References

Part Number	Output Voltage (V)	Initial Accuracy (%) (max)	Supply Voltage Range (V)	ISY (max)	Tempco (ppm/°C) (max)	Output Current Source/Sink (mA)	0.1 Hz to 10 Hz Noise		Temperature Range (°C)	Type	Package	ECCN Code
							µV p-p	ppm p-p				
LT6658 <i>New</i>	1.2, 1.8, 2.5, 3, 3.3, 5	0.05, 0.1	5 to 36	2 mA	10, 20	+150/-20		1.6	-40°C to +125°C	Series	16-lead DFN, 16-lead MSOP-EP	EAR99
LT1461	2.5, 3, 3.3, 4.096, 5	0.04, 0.06, 0.08, 0.15	2.8 to 20	50 µA	3, 7, 12, 20	50		8.0	-40°C to +125°C	Series	8-lead SO	EAR99
REF191	2.048	0.1, 0.49	3.0 to 15	45 µA	5, 25	30	20	9.8	-40°C to +85°C	Series	SOIC	EAR99
REF192	2.5	0.08, 0.2, 0.4	3.0 to 15	45	5, 10, 25	30	25	10.0	-40°C to +85°C	Series	TSSOP, SOIC	EAR99
REF198	4.096	0.05, 0.12, 0.24	4.5 to 15	45	5, 10, 25	30	40	9.8	-40°C to +85°C	Series	TSSOP, SOIC	EAR99
REF194	4.5	0.04, 0.2	4.75 to 15	45	5, 25	30	45	10.0	-40°C to +85°C	Series	SOIC	EAR99
REF195	5	0.04, 0.1, 0.2	5.15 to 15	45	5, 10, 25	30	50	10.0	-40°C to +85°C	Series	TSSOP, SOIC	EAR99
LT1460	2.5, 3, 3.3, 5, 10	0.075, 0.1, 0.125, 0.15, 0.2, 0.25, 0.4, 0.5	3.4 to 20	175	10, 15, 20, 25, 50	-1 to +20		4.0	-40°C to +125°C	Series	8-lead DIP, 8-lead SO, 8-lead MSOP, SOT-23	EAR99

Standard REF—Series Mode

Part Number	Output Voltage (V)	Initial Accuracy (%) (max)	Supply Voltage Range (V)	ISY (max)	Tempco (ppm/°C) (max)	Output Current Source/Sink (mA)	0.1 Hz to 10 Hz Noise		Temperature Range (°C)	Type	Package	ECCN Code
							µV p-p	ppm p-p				
LT6657 <i>New</i>	1.25, 2.048, 2.5, 3, 3.3, 4.096, 5	0.1	1.3 to 40	1.2 mA	1.5, 3	±10		0.5	-40°C to +125°C	Series	8-lead MSOP	EAR99
AD588	±5, ±10	0.01, 0.02, 0.03, 0.05, 0.06, 0.1	±18	10 mA	1.5, 3	-10 to +10	6		-55°C to +125°C	Series	SOIC	EAR99
LTC6655 <i>New</i>	1.25, 2.048, 2.5, 3, 3.3, 4.096, 5	0.025, 0.05	3.0 to 13.2	5 mA	2, 5	±10		0.25	-40°C to +125°C	Series	8-lead MSOP	EAR99
LT1027	5	0.05, 0.1	8 to 40	3.1 mA	2, 3, 5, 7.5	-10 to +15		0.6	-40°C to +85°C	Series	8-lead DIP	EAR99
ADR4520	2.048	0.02, 0.04	3.0 to 15	950 µA	2, 4	-10 to +10	1.25	0.6	-40°C to +125°C	Series	SOIC	EAR99
ADR4525	2.5	0.02, 0.04	3.0 to 15	950 µA	2, 4	-10 to +10	1.25	0.6	-40°C to +125°C	Series	SOIC	EAR99
ADR4530	3	0.02, 0.04	3.1 to 15	950 µA	2, 4	-10 to +10	1.6	0.6	-40°C to +125°C	Series	SOIC	EAR99
ADR4533	3.3	0.02, 0.04	3.4 to 15	950 µA	2, 4	-10 to +10	2.1	0.6	-40°C to +125°C	Series	SOIC	EAR99
ADR4540	4.096	0.02, 0.04	4.2 to 15	950 µA	2, 4	-10 to +10	2.7	0.6	-40°C to +125°C	Series	SOIC	EAR99
ADR4550	5	0.02, 0.04	5.1 to 15	950 µA	2, 4	-10 to +10	2.8	0.6	-40°C to +125°C	Series	SOIC	EAR99
AD586	5	0.04	10.8 to 36	3 mA	2, 5, 10	-5 to +10	4	0.8	-55°C to +125°C	Series	SOIC	EAR99
ADR440	2.048	0.05, 0.15	3.0 to 18	3.75 mA	3, 10	-5 to +10	1	0.5	-40°C to +125°C	Series	MSOP, SOIC	EAR99
ADR441	2.5	0.04, 0.12	3.0 to 18	3.75 mA	3, 10	-5 to +10	1.2	0.5	-55°C to +125°C	Series	MSOP, SOIC	EAR99
ADR443	3	0.04, 0.13	3.5 to 18	3.75 mA	3, 10	-5 to +10	1.4	0.5	-40°C to +125°C	Series	MSOP, SOIC	EAR99
ADR444	4.096	0.04, 0.13	4.5 to 18	3.75 mA	3, 10	-5 to +10	1.8	0.5	-40°C to +125°C	Series	MSOP, SOIC	EAR99
ADR445	5	0.04, 0.12	5.5 to 18	3.75 mA	3, 10	-5 to +10	2.25	0.5	-40°C to +125°C	Series	MSOP, SOIC	EAR99
ADR420	2.048	0.05, 0.15	4.0 to 18	600 µA	3, 10	10	1.75	0.9	-40°C to +125°C	Series	MSOP, SOIC	EAR99
ADR421	2.5	0.04, 0.12	4.5 to 18	600 µA	3, 10	10	1.75	0.7	-40°C to +125°C	Series	MSOP, SOIC	EAR99
ADR423	3	0.04, 0.13	5.0 to 18	600 µA	3, 10	10	2	0.7	-40°C to +125°C	Series	MSOP, SOIC	EAR99
ADR425	5	0.04, 0.12	7.0 to 18	600 µA	3, 10	10	3.4	0.7	-40°C to +125°C	Series	MSOP, SOIC	EAR99
ADR430	2.048	0.05, 0.15	4.1 to 18	800 µA	3, 10	-20 to +30	3.5	1.7	-40°C to +125°C	Series	MSOP, SOIC	EAR99
ADR431	2.5	0.04, 0.12	4.5 to 18	800 µA	3, 10	-20 to +30	3.5	1.5	-55°C to +125°C	Series	MSOP, SOIC	EAR99
ADR433	3	0.05, 0.13	5 to 18	800 µA	3, 10	-20 to +30	3.75	1.5	-40°C to +125°C	Series	MSOP, SOIC	EAR99
ADR434	4.096	0.04, 0.12	6.1 to 18	800 µA	3, 10	-20 to +30	6.25	1.5	-55°C to +125°C	Series	MSOP, SOIC	EAR99
ADR435	5	0.04, 0.12	7 to 18	800 µA	3, 10	-20 to +30	8	1.5	-55°C to +125°C	Series	MSOP, SOIC	EAR99
AD780	2.5	0.04, 0.2	4.0 to 36	1 mA	3, 7	±10	4	1.6	-40°C to +85°C	Series	SOIC	EAR99
AD688	±10	0.015, 0.03	±13.5 to 18	12 mA	3, 8	+10, -10	6		-55°C to +125°C	Series	SOIC	EAR99
ADR03	2.5	0.1, 0.2	4.5 to 36	1 mA	3, 9, 10, 25	10	6	2.4	-55°C to +125°C	Series	SC70, SOT-23, SOIC	EAR99
ADR06	3	0.1, 0.2	5.0 to 36	1 mA	3, 9, 25	10	10	3.3	-40°C to +125°C	Series	SC70, SOT-23, SOIC	EAR99
ADR02	5	0.06, 0.1	7.0 to 36	1 mA	3, 9, 10, 25, 40	10	10	2.0	-40°C to +125°C	Series	SC70, SOT-23, SOIC	EAR99

¹ DIP, TO-52, or TO-99 package offerings. ² 10 Hz to 10 kHz.

Voltage References

Standard REF—Series Mode (Continued)

Part Number	Output Voltage (V)	Initial Accuracy (%) (max)	Supply Voltage Range (V)	ISY (max)	Tempco (ppm/°C) (max)	Output Current Source/Sink (mA)	0.1 Hz to 10 Hz Noise		Temperature Range (°C)	Type	Package	ECCN Code
							µV p-p	ppm p-p				
ADR01	10	0.05, 0.1	12 to 36	1 mA	3, 9, 10, 25	10	20	2.0	−55°C to +125°C	Series	SC70, SOT-23, SOIC	EAR99
LT1461	2.5, 3, 3.3, 4.096, 5	0.04, 0.06, 0.08, 0.15	2.8 to 20	50 µA	3, 7, 12, 20	50		8.0	−40°C to +125°C	Series	8-lead SO	EAR99
LT1031	10	0.05, 0.1, 0.2	11 to 40	1.7 mA	5, 15, 25	±10	6	0.6	−55°C to +125°C	Series	TO-39	EAR99
LT1236	5, 10	0.05, 0.075, 0.1	10 to 40	1.2 mA	5, 10, 15	±10		0.6	−40°C to +85°C	Series	8-lead DIP, 8-lead SO	EAR99
LT1021	5, 7, 10	0.05, 1	7.2 to 40	1.2 mA	5, 20	±10		0.6	−55°C to +125°C	Series	TO-5, 8-lead DIP	EAR99
LTC6652	1.25, 2.048, 2.5, 3, 3.3, 4.096, 5	0.05, 0.1	2.8 to 13.2	560 µA	5, 10	±5		2.1	−40°C to +125°C	Series	8-lead MSOP	EAR99
LT1019	2.5, 4.5, 5, 10	0.05, 0.2	4 to 40	1 mA	5, 20	±10		2.5	−40°C to +85°C	Series	8-lead DIP, 8-lead SO	EAR99
ADR3512W <i>New</i>	1.2	0.1	2.3 to 5.5	100 µA	4, 8	−3 to +10	8	6.7	−40°C to +125°C	Series	MSOP	EAR99
ADR3525W <i>New</i>	2.5	0.1	2.7 to 5.5	100 µA	5, 8	−3 to +10	18	7.2	−40°C to +125°C	Series	MSOP	EAR99
ADR3530W <i>New</i>	3	0.1	3.2 to 5.5	100 µA	5, 8	−3 to +10	22	7.3	−40°C to +125°C	Series	MSOP	EAR99
ADR3533W <i>New</i>	3.3	0.1	3.5 to 5.5	100 µA	5, 8	−3 to +10	25	7.6	−40°C to +125°C	Series	MSOP	EAR99
ADR3540W <i>New</i>	4.096	0.1	4.3 to 5.5	100 µA	5, 8	−3 to +10	29	7.1	−40°C to +125°C	Series	MSOP	EAR99
ADR3550W <i>New</i>	5	0.1	5.2 to 5.5	100 µA	5, 8	−3 to +10	35	7.0	−40°C to +125°C	Series	MSOP	EAR99
REF191	2.048	0.1, 0.49	3.0 to 15	45 µA	5, 25	30	20	9.8	−40°C to +85°C	Series	SOIC	EAR99
REF192	2.5	0.08, 0.2, 0.4	3.0 to 15	45 µA	5, 10, 25	30	25	10.0	−40°C to +85°C	Series	TSSOP, SOIC	EAR99
REF198	4.096	0.05, 0.12, 0.24	4.5 to 15	45 µA	5, 10, 25	30	40	9.8	−40°C to +85°C	Series	TSSOP, SOIC	EAR99
REF194	4.5	0.04, 0.2	4.75 to 15	45 µA	5, 25	30	45	10.0	−40°C to +85°C	Series	SOIC	EAR99
REF195	5	0.04, 0.1, 0.2	5.15 to 15	45 µA	5, 10, 25	30	50	10.0	−40°C to +85°C	Series	TSSOP, SOIC	EAR99
AD581	10	0.05, 0.1, 0.3	13 to 30	1 mA	5, 10, 15, 30	5	40	4.0	−55°C to +125°C	Series	Other	EAR99
AD584	5	0.06, 0.12, 0.3	7.5 to 30	1 mA	5, 15, 30	+10	50	10.0	−55°C to +125°C	Series	Other	EAR99
AD584	7.5	0.05, 0.1, 0.27	10 to 30	1 mA	5, 15, 30	+10	50	6.7	−55°C to +125°C	Series	Other	EAR99
AD584	10	0.05, 0.1, 0.3	12.5 to 30	1 mA	5, 15, 30	+10	50	5.0	−55°C to +125°C	Series	Other	EAR99
ADR293	5	0.06, 0.2	6.0 to 15	20 µA	8, 25	5	15	3.0	−55°C to +125°C	Series	TSSOP, SOIC	EAR99
ADR3412 <i>New</i>	1.2	0.1	2.3 to 5.5	100 µA	8	−3 to +10	8	6.7	−40°C to +125°C	Series	SOT-23	EAR99
ADR3420 <i>New</i>	2.048	0.1	2.3 to 5.5	100 µA	8	−3 to +10	15	7.3	−40°C to +125°C	Series	SOT-23	EAR99
ADR3425 <i>New</i>	2.5	0.1	2.7 to 5.5	100 µA	8	−3 to +10	18	7.2	−40°C to +125°C	Series	SOT-23	EAR99
ADR3430 <i>New</i>	3	0.1	3.2 to 5.5	100 µA	8	−3 to +10	22	7.3	−40°C to +125°C	Series	SOT-23	EAR99
ADR3433 <i>New</i>	3.3	0.1	3.5 to 5.5	100 µA	8	−3 to +10	25	7.6	−40°C to +125°C	Series	SOT-23	EAR99
ADR3440 <i>New</i>	4.096	0.1	4.3 to 5.5	100 µA	8	−3 to +10	29	7.1	−40°C to +125°C	Series	SOT-23	EAR99
ADR3450 <i>New</i>	5	0.1	5.2 to 5.5	100 µA	8	−3 to +10	35	7.0	−40°C to +125°C	Series	SOT-23	EAR99
REF02	5	0.3	8.0 to 36	1.4 mA	8.5, 25, 65	10	15	3.0	−55°C to +125°C	Series	SOIC	EAR99
REF01	10	0.3	12 to 36	1.4 mA	8.5, 25, 65	10	30	3.0	−55°C to +125°C	Series	SOIC	EAR99
ADR391	2.5	0.16, 0.24	2.8 to 15	140 µA	9, 25	5	5	2.0	−40°C to +125°C	Series	SOT-23	EAR99
ADR392	4.096	0.12, 0.15	4.3 to 15	140 µA	9, 25	5	7	1.7	−40°C to +125°C	Series	SOT-23	EAR99
ADR395	5	0.1, 0.12	5.3 to 15	140 µA	9, 25	5	8	1.6	−40°C to +125°C	Series	SOT-23	EAR99
ADR360	2.048	0.15, 0.29	2.35 to 15	190 µA	9, 25	−1 to +5	6.8	3.3	−40°C to +125°C	Series	SOT-23	EAR99
ADR361	2.5	0.12, 0.24	2.8 to 15	190 µA	9, 25	−1 to +5	8.25	3.3	−40°C to +125°C	Series	SOT-23	EAR99
ADR363	3	0.1, 0.2	3.3 to 15	190 µA	9, 25	−1 to +5	8.7	2.9	−40°C to +125°C	Series	SOT-23	EAR99
ADR366	3.3	0.12, 0.25	3.6 to 15	190 µA	9, 25	−1 to +5	9.3	2.8	−40°C to +125°C	Series	SOT-23	EAR99
ADR364	4.096	0.1, 0.2	4.4 to 15	190 µA	9, 25	−1 to +5	11	2.7	−40°C to +125°C	Series	SOT-23	EAR99
ADR365	5	0.08, 0.16	5.3 to 15	190 µA	9, 25	−1 to +5	12.8	2.6	−40°C to +125°C	Series	SOT-23	EAR99
ADR127	1.25	0.12, 0.24	2.7 to 18	125 µA	9, 25	−2 to +5	9	7.2	−40°C to +125°C	Series	SOT-23	EAR99
LT6654 <i>New</i>	1.25, 2.048, 2.5, 3, 3.3, 4.096, 5	0.05, 0.1	1.75 to 36	350 µA	10, 20	±10		1.6	−55°C to +125°C	Series	SOT-23	EAR99

¹ DIP, TO-52, or TO-99 package offerings. ² 10 Hz to 10 kHz.

Voltage References

Standard REF—Series Mode (Continued)

Part Number	Output Voltage (V)	Initial Accuracy (%) (max)	Supply Voltage Range (V)	ISY (max)	Tempco (ppm/°C) (max)	Output Current Source/Sink (mA)	0.1 Hz to 10 Hz Noise		Temperature Range (°C)	Type	Package	ECCN Code
							µV p-p	ppm p-p				
LT6658 <i>New</i>	1.2, 1.8, 2.5, 3, 3.3, 5	0.05, 0.1	5 to 36	2 mA	10, 20	+150/−20		1.6	−40°C to +125°C	Series	16-lead MSE	EAR99
AD587	10	0.05, 0.1	13.5 to 36	4 mA	10, 20	±10	4	0.4	−55°C to +125°C	Series	SOIC	EAR99
REF43	2.5	0.1, 0.6	4.5 to 40	450 µA	10, 25	20/1.2	7	2.8	−40°C to +85°C	Series	SOIC	EAR99
AD580	2.5	0.4	4.5 to 30	1.5 mA	10, 25, 40, 85	10	8	3.2	−55°C to +125°C	Series	Other	EAR99
ADR291	2.5	0.08, 0.12, 0.24	3.0 to 15	15 µA	10, 20, 30	5	8	3.2	−40°C to +125°C	Series	TSSOP, SOIC	EAR99
ADR292	4.096	0.07, 0.1, 0.15	4.5 to 15	15 µA	10, 20, 30	5	12	2.9	−40°C to +125°C	Series	TSSOP, SOIC	EAR99
LT1460	2.5, 3, 3.3, 5, 10	0.075, 0.1, 0.125, 0.15, 0.2, 0.25, 0.4, 0.5	3.4 to 20	175 µA	10, 15, 20, 25, 50	−1 to 20		4.0	−40°C to +125°C	Series	8-lead DIP, 8-lead SO, 8-lead MSOP, SOT-23	EAR99
LT1790	1.2, 2.048, 2.5, 3, 3.3, 4.096, 5	0.05, 0.1	2.6 to 18	60 µA	10, 25	−3 to 5		16.0	−40°C to +85°C	Series	SOT-23	EAR99
LT6656	1.25, 2.048, 2.5, 3, 3.3, 4.096, 5	0.05, 0.1	2.51 to 18	0.85 µA	10, 20	−0.1 to 10		24.0	−40°C to +85°C	Series	SOT-23	EAR99
AD584	2.5	0.1, 0.14, 0.3	5.0 to 30	1 mA	10, 15, 30	5	50	20.0	−55°C to +125°C	Series	Other	EAR99
ADR827	1.25	0.2, 0.4	2.7 to 15	400 µA	15, 30	41762	8	6.4	−40°C to +125°C	Series	MSOP	EAR99
LT6660H	2, 3, 3.3, 5, 10	0.2, 0.4, 0.5	3.4 to 20	200 µA	20, 50	−1 to +20		4.0	0°C to 70°C	Series	DFN	EAR99
AD680	2.5	0.2, 0.4	4.5 to 36	280 µA	20, 25, 30	10	10	4.0	−40°C to +85°C	Series	SOIC	EAR99
ADR380	2.048	0.24	2.4 to 18	140 µA	25	5	5	2.4	−40°C to +85°C	Series	SOT-23	EAR99
ADR381	2.5	0.24	2.8 to 18	140 µA	25	5	5	2.0	−40°C to +85°C	Series	SOT-23	EAR99
ADR130	0.5	0.35, 0.70	2.0 to 18	150 µA	25, 50	4/2	3	6.0	−40°C to +125°C	Series	SOT-23	EAR99
ADR130	1	0.35, 0.70	2.0 to 18	150 µA	25, 50	4/2	6	6.0	−40°C to +125°C	Series	SOT-23	EAR99
REF193	3	0.33	3.3 to 15	45 µA	25	25	30	10.0	−40°C to +85°C	Series	SOIC	EAR99
REF196	3.3	0.3	3.5 to 15	45 µA	25	25	33	10.0	−40°C to +85°C	Series	TSSOP, SOIC	EAR99
ADR225	2.5	0.4, 2.4	3.3 to 15	50 µA	30, 80	10	25	10.0	−40°C to 210°C	Series	SOIC	EAR99
LT6650	Adjustable	0.5	1.4 to 18	11 µA	30 typ	±0.2		50.0	−40°C to +125°C	Series	SOT-23	EAR99
LTC1798	2.5, 3, 4.096, 5	0.15	2.7 to 12.6	6.5 µA	40	−2 to +10		8.0	0°C to 70°C	Series	8-lead SO	EAR99
LTC1258	2.5, 3, 4.096, 5	0.15	2.7 to 12.6	6.5 µA	40	−2 to +10		8.0	0°C to 70°C	Series	8-lead MSOP, 8-lead SO	EAR99
REF03	2.5	0.6	4.5 to 33	1.4 mA	50	10/0.5	6	2.4	−40°C to +85°C	Series	SOIC	EAR99
AD1582	2.5	0.08, 0.8	2.7 to 12	70 µA	50, 100	±5	70	28.0	−40°C to +125°C	Series	SOT-23	EAR99
AD1583	3	0.1, 1.0	3.2 to 12	70 µA	50, 100	±5	85	28.3	−40°C to +125°C	Series	SOT-23	EAR99
AD1584	4.096	0.1, 0.98	4.3 to 12	70 µA	50, 100	±5	110	26.9	−40°C to +125°C	Series	SOT-23	EAR99
AD1585	5	0.1, 1.0	5.2 to 12	70 µA	50, 100	±5	140	28.0	−40°C to +125°C	Series	SOT-23	EAR99

¹ DIP, TO-52, or TO-99 package offerings. ² 10 Hz to 10 kHz.

Standard REF—Shunt Mode

Part Number	Output Voltage (V)	Initial Accuracy (%)	Current Range		Tempco (ppm/°C) (max)	Output Impedance (Ω)	0.1 Hz to 10 Hz Noise		Temperature Range (°C)	Type	Package	ECCN Code
			Min	Max (mA)			µV p-p	ppm p-p				
LTZ1000	7	0.04			0.05		1.2	0.17	−55°C to +125°C	Shunt	TO-5	EAR99
LM399A	7	0.05			1, 2	1.5	10	1.4	0°C to 70°C	Shunt	TO-46	EAR99
LT6657 <i>New</i>	1.25, 2.048, 2.5, 3, 3.3, 4.096, 5	0.1	2.5 mA	11	1.5, 3			0.5	−40°C to +125°C	Shunt	8-lead MSOP	EAR99
LT1389	1.2, 2.5, 4.096, 5	0.05, 0.075	0.6 µA	2	10, 20, 50	1		20	0°C to 70°C	Shunt	8-lead SO	EAR99
LT1634	1.2, 2.5, 4.096, 5	0.05	8 µA	20	10, 25	1		7	−40°C to +85°C	Shunt	8-lead SO, 8-lead MSOP, TO-92	EAR99
AD589	1.2	1.2	50 µA	5	10, 50, 100	0.6			−55°C to +125°C	Shunt	SOIC, Other	EAR99

Voltage References

Standard REF—Shunt Mode (Continued)

Part Number	Output Voltage (V)	Initial Accuracy (%)	Current Range		Tempco (ppm/°C) (max)	Output Impedance (Ω)	0.1 Hz to 10 Hz Noise		Temperature Range °C	Type	Package	ECCN Code
			Min (μA)	Max (mA)			μV p-p	ppm p-p				
LT1029	5	0.2, 1	700 μA	10	20, 34	0.6			–55°C to +125°C	Shunt	T0-92	EAR99
LT1004	1.2, 2.5	0.003	10 μA	20	20 typ	0.6			–40°C to +85°C	Shunt	8-lead SO, T0-92	EAR99
LT1034	1.2, 2.5, 7	0.012	20 μA	20	20, 40	1		2.4	–40°C to +85°C	Shunt	8-lead SO, T0-92	EAR99
LT1009	2.5	0.002	400 μA	10	25	0.6			–40°C to +85°C	Shunt	8-lead SO, 8-lead MSOP, T0-92	EAR99
LTC1431	Adjustable	0.004	1 μA	100	30 Typ	0.1	10		–55°C to +125°C	Shunt	8-lead DIP, T0-92	EAR99
ADR525	2.5	0.2, 0.4	50 μA	15	40, 70	0.27	18	7.2	–40°C to +85°C	Shunt	SC70, SOT-23	EAR99
ADR530	3	0.2, 0.4	50 μA	15	40, 70	0.27	22	7.3	–40°C to +85°C	Shunt	SC70, SOT-23	EAR99
ADR550	5	0.2, 0.4	50 μA	15	40, 70	0.27	48	9.6	–40°C to +85°C	Shunt	SC70, SOT-23	EAR99
ADR1581	1.25	0.08, 0.8	60 μA	10	50, 100	0.5	4.5	3.6	–40°C to +85°C	Shunt	SOT-23	EAR99
AD1580	1.225	0.08, 0.8	50 μA	10	50, 100	0.5	5	4.1	–40°C to +85°C	Shunt	SC70, SOT-23	EAR99
ADR512	1.2	0.3	100 μA	10	60	0.3	4	3.3	–40°C to +85°C	Shunt	SOT-23	EAR99
ADR5040 <i>New</i>	2.048	0.1, 0.2	50 μA	15	75, 100	0.2	16.8	8.2	–40°C to +125°C	Shunt	SC70, SOT-23	EAR99
ADR5041 <i>New</i>	2.5	0.1, 0.2	50 μA	15	75, 100	0.2	19.2	7.7	–40°C to +125°C	Shunt	SC70, SOT-23	EAR99
ADR5043 <i>New</i>	3	0.1, 0.2	50 μA	15	75, 100	0.2	25.8	8.6	–40°C to +125°C	Shunt	SC70, SOT-23	EAR99
ADR5044 <i>New</i>	4.096	0.1, 0.2	50 μA	15	75, 100	0.2	32.2	7.9	–40°C to +125°C	Shunt	SC70, SOT-23	EAR99
ADR5045 <i>New</i>	5	0.1, 0.2	50 μA	15	75, 100	0.2	39.6	7.9	–40°C to +125°C	Shunt	SC70, SOT-23	EAR99
ADR510	1	0.35	100 μA	10	85	0.3	4	4.0	–40°C to +85°C	Shunt	SOT-23	EAR99
ADR1500	1.288	0.2	50 μA	10	220	1	5	3.9	–40°C to +85°C	Shunt	SC70	EAR99

Switches and Multiplexers

ADGM1004: SP4T MEMS Switch with Integrated Driver 0 Hz/DC to 13 GHz Bandwidth, 5 kV HBM ESD on RF Pins

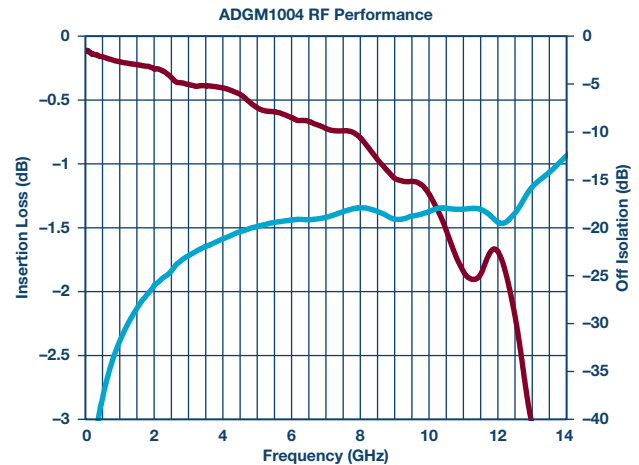
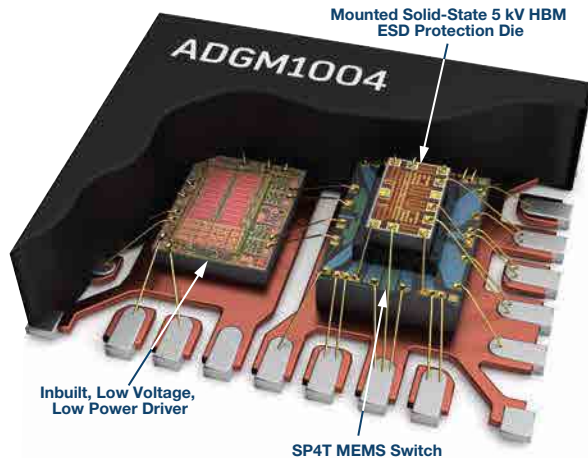

Family Benefits

- ▶ Increased channel density with up to 95% reduction in volume vs. competitive RF relay solutions
 - 80% reduction in x-y area and <1.5 mm height, which allows dual side placement
- ▶ Increased DUT throughput with 20× improvement in switching speed
 - 10× reduction in current consumption, which enables concurrent switching

▶ Improved reliability vs. RF relays

- 10× increase in cold-switching lifetime
- Removal of manual handling concerns via integrated 5 kV HBM ESD on RF pins
- 10× reduction in power consumption with integrated charge pump

Family Applications

- ▶ RF relay and reed relay replacement for precision and RF applications
- ▶ Instrumentation, ATE, and high multichannel systems

Switches and Multiplexers

0 Hz/DC to RF Performance, MEMS Switches with Integrated Driver

Part Number	Configuration	Specifications									Interface	HBM ESD Level—RF Pins (kV)	Package	ECCN Code
		R _{ON} (Ω) (typ)	Off Leakage (nA) (typ)	Frequency Response (Hz) (min)	Frequency Response (GHz) (max)	Insertion Loss (dB) (typ)	Off Isolation (dB) (typ)	IIP3 (dBm) (typ)	Input Power (dBm) (max)	Specified at Frequency (GHz)				
ADGM1304 <i>New</i>	(4:1) × 1	1.6	0.5	0	14	0.26	24	69	36	2.5	Parallel	0.1	LFCSP	EAR99
ADGM1004 <i>New</i>	(4:1) × 1	1.8	0.5	0	13	0.45	24	67	32	2.5	Parallel	5	LFCSP	EAR99

SPI+ Interface with Digital Error Detection

Part Number	Configuration	Specifications				Characterization Voltages (V _{DDM})						Interface	Package	ECCN Code	
		R _{ON} (Ω) (typ)	On Leakage (nA) (typ)	Q _{INJ} (pC) (typ)	BW (MHz)	Single				Dual					
						3.3	5	12	36	±5	±15				±20
ADGS1412 <i>New</i>	SPST × 4	1.5	0.15	20	170		•	•		•	•		SPI+	LFCSP	EAR99
ADGS5412 <i>New</i>	SPST × 4	9.8	0.1	245	167			•	•		•	•	SPI+	LFCSP	EAR99
ADGS1212 <i>New</i>	SPST × 4	120	0.02	0.9	1000			•			•		SPI+	LFCSP	EAR99
ADGS1612 <i>New</i>	SPST × 4	1	0.2	120	34	•	•	•			•		SPI+	LFCSP	EAR99
ADGS5414 <i>New</i>	SPST × 8	13.5	0.15	125	200			•	•		•	•	SPI+	LFCSP	EAR99
ADGS1208/ADGS1209 <i>New</i>	8:1 diff, 4:1 mux	120	0.02	0.4	550			•			•		SPI+	LFCSP	EAR99
ADGS1408/ADGS1409 <i>New</i>	8:1 diff, 4:1 mux	4	0.1	50	60			•	•		•	•	SPI+	LFCSP	EAR99

SPI+: SPI device, which has multiple modes of operation.

Overvoltage Detection and Protection: –55 V OVP to +55 V OVP

Part Number	Configuration	HBM ESD Level (kV)	Specifications					Characterization Voltages (V _{DDM})				Interface	Package	ECCN Code
			R _{ON} (Ω) (typ)	R _{ON} Flatness (Ω)	On Leakage (nA) (typ)	Q _{INJ} (pC) (typ)	BW (MHz)	Single		Dual				
								12	36	±15	±20			
ADG5412F/ADG5413F	SPST × 4	5.5	10	0.6	0.3	680	270	•	•	•	•	Parallel	TSSOP,* LFCSP	EAR99
ADG5412BF/ADG5413BF	SPST × 4	3	10	0.6	0.3	680	270	•	•	•	•	Parallel	TSSOP, LFCSP	EAR99
ADG5436F <i>New</i>	SPDT × 2	6	10	0.6	0.3	654	108	•	•	•	•	Parallel	TSSOP, LFCSP	EAR99
ADG5243F <i>New</i>	SPDT × 3	3.5	270	7	0.3	0.8	350	•	•	•	•	Parallel	TSSOP, LFCSP	EAR99
ADG5404F	4:1 mux	5	10	0.6	0.3	680	108	•	•	•	•	Parallel	TSSOP, LFCSP	EAR99
ADG5208F/ADG5209F <i>New</i>	8:1 diff, 4:1 mux	3.5	250	6.5	0.3	0.4	190/290	•	•	•	•	Parallel	TSSOP, LFCSP	EAR99
ADG5248F/ADG5249F <i>New</i>	8:1 diff, 4:1 mux	3.5	250	6.5	0.3	0.8	190/320	•	•	•	•	Parallel	TSSOP, LFCSP	EAR99

*Enhanced product switch available in addition to standard switch for specific package.

Channel Overvoltage Detection and Protection: –55 V OVP to +55 V OVP

Part Number	Configuration	HBM ESD Level (kV)	Specifications					Characterization Voltages (V _{DDM})				Interface	Package	ECCN Code
			R _{ON} (Ω) (typ)	R _{ON} Flatness (Ω)	On Leakage (nA) (typ)	Q _{INJ} (pC) (typ)	BW (MHz)	Single		Dual				
								12	36	±15	±20			
ADG5462F	Channel protector × 4	4	10	0.6	0.3	—	318	•	•	•	•	—	TSSOP, LFCSP	EAR99

Switches and Multiplexers

ADG5401F: Delivering Overvoltage Protection with a Robust Feature Set for Analog Output Protection

Analog Devices offers a range of switches that guarantee latch-up immunity and overvoltage protection up to ± 60 V for harsh environment or industrial applications with supply operating voltages up to ± 22 V. Using ADI's trench isolation process, these devices are immune to latch-up, which is an undesirable high current state that persists until the power supply is turned off and that can lead to device failure.

Benefits

The **ADG5401F** provides analog output overvoltage protection up to ± 60 V while ensuring open-loop prevention around the output drive amplifier.

- ▶ **Overvoltage protection:** The switch turns off and is guaranteed to withstand specified voltages on the analog inputs that exceed the switch supply voltage. For overvoltage conditions, the switch is guaranteed to be in a high impedance state protecting downstream analog components.
- ▶ **Overvoltage detection:** Digital indicator to signal the presence of an overvoltage condition, thereby enabling the channel in fault to be avoided or corrective action to be taken.
- ▶ **Feedback channel:** This higher resistance channel is used to eliminate any error that would otherwise be caused by the switch resistance.
- ▶ **Open-loop prevention:** An internal switch prevents the amplifier from going into an open-loop state.
- ▶ **Power-on condition:** A user selectable feature that prevents source node from floating.
- ▶ **Power-off protection:** The device is guaranteed in a high impedance off state with no power supplies present.

Applications

- ▶ DAC and amplifier output protection
- ▶ Analog input/output modules
- ▶ Process control/distributed control systems
- ▶ Sensor bias

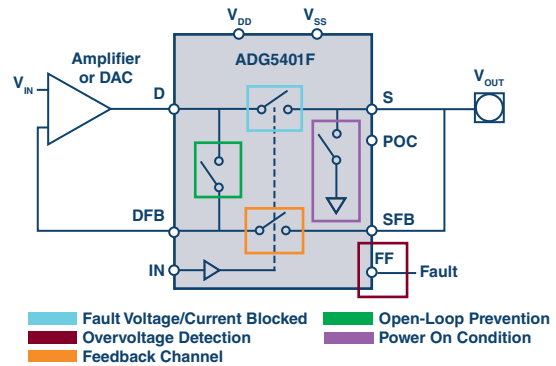

Optimized for robustness and protection, the overvoltage protection and detection ADG5401F also offers high performance in an industry-leading small package. ADG5401f protection is delivered in a 3 mm x 2 mm LFCSP package.

Overvoltage Detection and Protection: -60 V OVP to +60 V OVP

Part Number	Configuration	Specifications				Comment	Characterization Voltages (V_{NOM})				Interface	Package	ECCN Code
		R_{ON} (Ω) (typ)	R_{ON} Flatness (Ω)	On Leakage (nA) (typ)			Single		Dual				
							12	36	± 15	± 20			
<i>± 15 V Analog</i>													
ADG5401F	SPST x 1	7	0.5	0.2	Additional feedback channel, used for DAC and amplifier output protection	•	•	•	•	Parallel	LFCSP	EAR99	
ADG5421F	SPST x 2	20	2	0.1		•	•	•	•	Parallel	LFCSP	EAR99	

Channel Overvoltage Protection: -40 V OVP to +40 V OVP

Part Number	Configuration	Specifications					Characterization Voltages (V_{NOM})				Interface	Package	ECCN Code
		R_{ON} (Ω) (typ)	R_{ON} Flatness (Ω)	On Leakage (nA) (typ)	Q_{INJ} (pC) (typ)	BW (MHz)	Single		Dual				
							5	12	± 5	± 15			
ADG465	Channel protector x 1	80	—	0.2	—	—			•	Parallel	SOT-23, MSOP	EAR99	
ADG467	Channel protector x 8	62	—	0.2	—	21			•	Parallel	SOIC, SSOP	EAR99	

Switches and Multiplexers

Overvoltage Protection: –5.5 V OVP to +16 V OVP

Part Number	Configuration	Specifications					Characterization Voltages (V_{NOM})				Interface	Package	ECCN Code
		R_{ON} (Ω) (typ)	R_{ON} Flatness (Ω)	On Leakage (nA) (typ)	Q_{INJ} (pC) (typ)	BW (MHz)	Single		Dual				
							5	12	± 5	± 15			
ADG4612/ ADG4613	SPST \times 4	5.2	1.4	10	225	293	•	•	•		Parallel	TSSOP, LFCSP	EAR99

± 15 V Latch-Up Immune and High ESD

Part Number	Configuration	HBM ESD Level I/O Port to I/O Port (kV)	HBM ESD Level—All Other Pins (kV)	Specifications				Characterization Voltages (V_{NOM})				Interface	Package	ECCN Code
				R_{ON} (Ω) (typ)	On Leakage (nA) (typ)	Q_{INJ} (pC) (typ)	BW (MHz)	Single		Dual				
								12	36	± 15	± 20			
ADG5401	SPST \times 1	8	8	6.5	0.2	220	170	•	•	•	•	Parallel	LFCSP, MSOP	EAR99
ADG5421/ADG5423	SPST \times 2	8	8	13.5	0.1	240	250	•	•	•	•	Parallel	LFCSP, MSOP	EAR99
ADG5412/ADG5413	SPST \times 4	8	8	9.8	0.1	240	167	•	•	•	•	Parallel	TSSOP, LFCSP	EAR99
ADG5212/ADG5213	SPST \times 4	2.5	2.5	160	0.02	0.07	435	•	•	•	•	Parallel	TSSOP, LFCSP	EAR99
ADG5419	SPDT \times 1	8	8	13.5	0.1	130	190	•	•	•	•	Parallel	LFCSP, MSOP	EAR99
ADG5436	SPDT \times 2	8	8	9.8	0.1	200	102	•	•	•	•	Parallel	TSSOP, LFCSP	EAR99
ADG5236	SPDT \times 2	2	2	160	0.02	0.6	266	•	•	•	•	Parallel	TSSOP, LFCSP	EAR99
ADG5433	SPDT \times 3	8	8	13.5	0.1	130	145	•	•	•	•	Parallel	TSSOP, LFCSP	EAR99
ADG5233	SPDT \times 3	1.5	8	160	0.08	0.6	205	•	•	•	•	Parallel	TSSOP, LFCSP	EAR99
ADG5434	SPDT \times 4	8	8	13.5	0.1	130	145	•	•	•	•	Parallel	TSSOP, LFCSP	EAR99
ADG5234	SPDT \times 4	1.5	8	160	0.08	0.6	205	•	•	•	•	Parallel	TSSOP, LFCSP	EAR99
ADG5404	4:1 mux	8	8	9.8	0.1	220	53	•	•	•	•	Parallel	TSSOP, LFCSP	EAR99
ADG5204	4:1 mux	2	2	160	0.02	0.6	136	•	•	•	•	Parallel	TSSOP, LFCSP	EAR99
ADG5408/ADG5409	8:1 diff, 4:1 mux	8	8	13.5	0.1	115	50	•	•	•	•	Parallel	TSSOP, LFCSP*	EAR99
ADG5208/ADG5209	8:1 diff, 4:1 mux	2	8	160	0.01	0.4	54/133	•	•	•	•	Parallel	TSSOP,* LFCSP	EAR99
ADG5206/ADG5207	16:1 diff, 8:1 mux	1	8	155	0.02	0.35	60/140	•	•	•	•	Parallel	TSSOP, LFCSP	EAR99

*Enhanced product switch available in addition to standard switch for specific package.

± 15 V Analog

Part Number	Configuration	Specifications				Characterization Voltages (V_{NOM})				Interface	Package	ECCN Code
		R_{ON} (Ω) (typ)	On Leakage (nA) (typ)	Q_{INJ} (pC) (typ)	BW (MHz)	Single		Dual				
						5	12	± 5	± 15			
ADG1401/ADG1402	SPST \times 1	1	0.2	12	120	•	•	•	•	Parallel	LFCSP, MSOP	EAR99
ADG417	SPST \times 1	25	0.1	7	—	•	•	•	•	Parallel	DIP, SOIC	EAR99
ADG1201	SPST \times 1	120	0.04	0.8	660	•	•	•	•	Parallel	SOT	EAR99
ADG1421/ADG1422/ADG1423	SPST \times 2	2.1	0.2	5	180	•	•	•	•	Parallel	LFCSP, MSOP	EAR99
ADG1221/ADG1222/ADG1223	SPST \times 2	120	0.01	0.1	960	•	•	•	•	Parallel	MSOP	EAR99
ADG1411/ADG1412/ADG1413	SPST \times 4	1.5	0.15	20	170	•	•	•	•	Parallel	TSSOP, LFCSP	EAR99
LTC201A/LTC202/LTC203	SPST \times 4	65	0.02	5	—	•	•	•	•	Parallel	DIP, SOIC	EAR99
LTC221/LTC222	SPST \times 4	65	0.02	5	—	•	•	•	•	Parallel	DIP, SOIC	EAR99
ADG1211/ADG1212/ADG1213	SPST \times 4	120	0.02	0.3	1000	•	•	•	•	Parallel	TSSOP,* LFCSP	EAR99
ADG1311/ADG1312/ADG1313	SPST \times 4	130	10	2	600	•	•	•	•	Parallel	TSSOP, SOIC	EAR99
ADG1414	SPST \times 8	9.5	0.1	10	256	•	•	•	•	SPI	TSSOP, LFCSP	EAR99
ADG1419	SPDT \times 1	2.1	0.2	16	135	•	•	•	•	Parallel	LFCSP, MSOP	EAR99
ADG1219	SPDT \times 1	120	0.02	0.1	520	•	•	•	•	Parallel	SOT	EAR99
ADG1436	SPDT \times 2	1.5	0.1	20	110	•	•	•	•	Parallel	TSSOP, LFCSP	EAR99
ADG1236	SPDT \times 2	120	0.02	1	1000	•	•	•	•	Parallel	TSSOP, LFCSP	EAR99
ADG1433/ADG1434	SPDT \times 3/SPDT \times 4	4	0.05	50	200	•	•	•	•	Parallel	TSSOP, LFCSP	EAR99
ADG1233/ADG1234	SPDT \times 3/SPDT \times 4	120	0.02	0.5	900	•	•	•	•	Parallel	TSSOP, LFCSP	EAR99
ADG1334	SPDT \times 4	130	10	2	700	•	•	•	•	Parallel	SSOP	EAR99
ADG1404	4:1 mux	1.5	0.1	20	55	•	•	•	•	Parallel	TSSOP, LFCSP	EAR99

*Enhanced product switch available in addition to standard switch for specific package.

Switches and Multiplexers

±15 V Analog (Continued)

Part Number	Configuration	Specifications				Characterization Voltages (V _{NOM})				Interface	Package	ECCN Code
		RON (Ω) (typ)	On Leakage (nA) (typ)	QINJ (pC)	BW (MHz)	Single		Dual				
						5	12	±5	±15			
ADG1204	4:1 mux	120	0.02	0.7	800		•	•	•	Parallel	TSSOP, LFCSP	EAR99
ADG1408/ADG1409	8:1 diff, 4:1 mux	4	0.1	50	60/115	•	•	•	•	Parallel	TSSOP,* LFCSP	EAR99
ADG1438/ADG1439	8:1 diff, 4:1 mux	9.5	0.1	4	82/130	•	•	•	•	SPI	TSSOP, LFCSP	EAR99
ADG1208/ADG1209	8:1 diff, 4:1 mux	120	0.02	0.4	550		•	•	•	Parallel	TSSOP, LFCSP, SOIC	EAR99
ADG1308/ADG1309	8:1 diff, 4:1 mux	130	1	2	500		•		•	Parallel	TSSOP, SOIC	EAR99
ADG1406/ADG1407	16:1 diff, 8:1 mux	9.5	0.05	10	60/110	•	•	•	•	Parallel	TSSOP, LFCSP	EAR99
ADG1206/ADG1207	16:1 diff, 8:1 mux	120	0.08	0.5	280/490		•	•	•	Parallel	TSSOP, LFCSP	EAR99

*Enhanced product switch available in addition to standard switch for specific package.

±5 V Analog

Part Number	Configuration	Specifications				Characterization Voltages (V _{NOM})							Interface	Package	ECCN Code
		R _{ON} (Ω) (typ)	On Leakage (nA) (typ)	Q _{INJ} (pC) (typ)	BW (MHz)	Single			Dual						
						2 to 12	2.7 to 5.5	3.3 to 16	±5	±2 to ±6	±2.7 to ±5.5	±3.3 to ±8			
ADG601/ADG602	SPST × 1	2	0.01	250	180		•				•		Parallel	SOT, MSOP	EAR99
ADG621	SPST × 2	4	0.01	110	230		•				•		Parallel	MSOP	EAR99
ADG1611/ADG1612/ ADG1613	SPST × 4	1	0.2	140	42			•				•	Parallel	TSSOP, LFCSP	EAR99
ADG511/ADG512/ADG513	SPST × 4	30	0.05	11	—		•				•		Parallel	DIP, CerDIP, SOIC	EAR99
ADG611/ADG612/ADG613	SPST × 4	85	0.01	0.5	680		•				•		Parallel	TSSOP,*	EAR99
ADG619	SPDT × 1	4	0.01	110	190		•				•		Parallel	SOT,* MSOP	EAR99
ADG1636	SPDT × 2	1	0.3	130	25			•				•	Parallel	TSSOP, LFCSP	EAR99
ADG636	SPDT × 2	85	0.01	1.2	610		•				•		Parallel	TSSOP	EAR99
ADG1633	SPDT × 3	4.5	0.02	12.5	103			•			•		Parallel	TSSOP, LFCSP	EAR99
ADG633	SPDT × 3	52	0.005	2	580	•					•		Parallel	TSSOP, LFCSP	EAR99
ADG1634	SPDT × 4	4.5	0.02	12.5	103			•			•		Parallel	TSSOP, LFCSP	EAR99
ADG1604	4:1 mux	1	0.2	140	15			•			•		Parallel	TSSOP, LFCSP	EAR99
ADG604	4:1 mux	85	0.01	1	280		•				•		Parallel	TSSOP	EAR99
ADG608/ADG609	8:1 diff, 4:1 mux	22	0.05	6	—		•				•		Parallel	TSSOP, DIP, SOIC	EAR99
ADG1608/ADG1609	8:1 diff, 4:1 mux	4.5	0.03	24	40/71			•			•		Parallel	TSSOP, LFCSP	EAR99
LTC1380/LTC1393	8:1 diff, 4:1 mux	35	0.05	1	—		•		•				SMBus, I ² C	SOIC, QSOP	EAR99
ADG658/ADG659	8:1 diff, 4:1 mux	45	0.005	2	160	•					•		Parallel	TSSOP, LFCSP, QSOP	EAR99
LTC1390	8:1 mux	45	0.05	2	—		•		•				SPI	DIP, SOIC	EAR99
LTC1391	8:1 mux	45	0.05	2	—		•		•				SPI	DIP, SOIC, QSOP	EAR99
ADG1606/ADG1607	16:1 diff, 8:1 mux	4.5	0.1	27	21/37			•			•		Parallel	TSSOP, LFCSP	EAR99

*Enhanced product switch available in addition to standard switch for specific package.

Low Voltage DC to High Frequency RF

Part Number	Configuration	Specifications				Characterization Voltages (V _{NOM})		Interface	Package	ECCN Code
		Off Isolation	Insertion Loss	Power (dBm)	-3 dB BW (MHz)	Single				
ADG901/ADG902	SPST × 1	40 dB (1 GHz)	0.8 dB (1 GHz)	17	4500	1.65 to 2.75		Parallel	LFCSP,* MSOP	EAR99
ADG918/ADG919	SPDT × 1	43 dB (1 GHz)	0.8 dB (1 GHz)	17	4000	1.65 to 2.75		Parallel	LFCSP, MSOP	EAR99
ADG936/ADG936-R	SPDT × 2	36 dB (1 GHz)	0.9 dB (1 GHz)	16	4000	1.65 to 2.75		Parallel	TSSOP, LFCSP	EAR99
ADG904/ADG904-R	4:1 mux	37 dB (1 GHz)	1.1 dB (1 GHz)	16	2500	1.65 to 2.75		Parallel	TSSOP, LFCSP*	EAR99

*Enhanced product switch available in addition to standard switch for specific package.

Switches and Multiplexers

Unbuffered Analog Crosspoint Arrays

Part Number	Configuration	Specifications				Characterization Voltages (V_{NOM})		Interface	Packaging	ECCN Code
		R_{ON} (Ω) (typ)	On Leakage (nA) (typ)	Q_{INJ} (pC) (typ)	BW (MHz)	Single	Dual			
						12	± 5			
ADG2128	8 mm \times 12 array	30	0.03	3.5	300	•	•	I ² C	LFCSP	EAR99
ADG2188	8 mm \times 8 array	30	0.03	3.5	300	•	•	I ² C	LFCSP	EAR99

Bus Switches

Part Number	Configuration	Specifications				Characterization Voltages (V_{NOM})						Level Translation	Package	ECCN Code
		R_{ON} (Ω) (typ)	Propagation Delay (ps) (max)	Bus Enable (ns) (typ)	Data Rate (Mbps)	Single				Dual				
						1.15 to 5.5	1.65 to 3.6	2.3 to 3.6	3.3 to 5.0	0 to -24.2	10.8 to 35			
ADG3241	1-bit bidirectional	4.5	225	3.2	1500			•				Down	SC70	EAR99
ADG3242	2-bit bidirectional	4.5	225	3.2	1500			•				Down	SOT-23, die	EAR99
ADG3243	2-bit bidirectional	4.5	225	3.2	1500			•				Down	SOT-23	EAR99
ADG3245	8-bit bidirectional	4.5	225	3.2	1244			•				Down	TSSOP, LFCSP	EAR99
ADG3246	10-bit bidirectional	4.5	225	3.2	1244			•				Down	LFCSP	EAR99
ADG3247	16-bit bidirectional	4.5	225	3.2	1244			•				Down	TSSOP	EAR99
ADG3248	1-bit 2:1 bidirectional	4.5	225	3.2	1244			•				Down	SC70	EAR99
ADG3257	4-bit 2:1 bidirectional	2	100	5	933				•			Down	QSOP	EAR99

Level Translators

Part Number	Configuration	Specifications				Characterization Voltages (V_{NOM})						Level Translation	Package	ECCN Code
		R_{ON} (Ω) (typ)	Propagation Delay (ps) (max)	Bus Enable (ns) (typ)	Data Rate (Mbps)	Single				Dual				
						1.15 to 5.5	1.65 to 3.6	2.3 to 3.6	3.3 to 5.0	0 to -24.2	10.8 to 35			
ADG3231	1-bit unidirectional	—	4000	—	—			•				Up/down	SOT-23	EAR99
ADG3233	1-bit bypass unidirectional	—	3500	4	—			•				Up/down	SOT-23, MSOP	EAR99
ADG3123	8-bit CMOS to HV unidirectional	—	8000	—	0.2					•	•	Up	TSSOP	EAR99
ADG3301	1-bit bidirectional	—	5000	1000	50	•						Up/down	SC70	EAR99
ADG3304	4-bit bidirectional	—	5000	1000	50	•						Up/down	TSSOP,* LFCSP, WLCSP	EAR99
ADG3300	8-bit bidirectional	—	5000	1000	50	•						Up/down	TSSOP	EAR99
ADG3308/ ADG3308-1	8-bit bidirectional	—	5000	1000	50	•						Up/down	TSSOP, LFCSP, WLCSP	EAR99

*Enhanced product switch available in addition to standard switch for specific package.

<5.5 V Analog

Part Number	Configuration	Specifications				Characterization Voltages (V_{NOM})				Interface	Package	ECCN Code	
		R_{ON} (Ω) (typ)	On Leakage (nA) (typ)	Q_{INJ} (pC) (typ)	BW (MHz)	Single			Dual				
						1.65 to 3.6	2.7 to 5.5	1.8 to 5.5	± 2.5				
ADG801/ADG802	SPST \times 1	0.25	0.01	50	12				•		Parallel	SOT, MSOP	EAR99
ADG841/ADG842	—	0.28	0.2	200	21	•					Parallel	SC70	EAR99
ADG701/ADG702/ADG701L/ ADG702L	SPST \times 1	2	0.01	5	200				•		Parallel	SOT, MSOP	EAR99
ADG741/ADG742	SPST \times 1	2	0.01	5	200				•		Parallel	SC70	EAR99
ADG751	SPST \times 1	15	0.01	1	300				•		Parallel	SOT, MSOP	EAR99
ADG821/ADG822/ADG823	SPST \times 2	0.5	0.01	15	24				•		Parallel	MSOP	EAR99
ADG721/ADG722/ADG723	SPST \times 2	2.5	0.01	2	200				•		Parallel	LFCSP, MSOP	EAR99
ADG811/ADG812	SPST \times 4	0.5	0.2	30	90	•					Parallel	TSSOP	EAR99
ADG711/ADG712/ADG713	SPST \times 4	2.5	0.01	3	200				•		Parallel	TSSOP, SOIC	EAR99
ADG781/ADG782/ADG783	SPST \times 4	2.5	0.01	3	200				•	•	Parallel	LFCSP	EAR99
ADG714	SPST \times 8	2.5	0.01	3	155		•			•	SPI	TSSOP	EAR99
ADG715	SPST \times 8	2.5	0.01	3	155		•			•	I ² C	TSSOP	EAR99
ADG819	SPDT \times 1	0.5	0.01	20	17				•		Parallel	SOT, MSOP, WLCSP	EAR99
ADG839	SPDT \times 1	0.35	0.2	70	25	•					Parallel	SC70	EAR99

*Enhanced product switch available in addition to standard switch for specific package.

Switches and Multiplexers

<5.5 V Analog (Continued)

Part Number	Configuration	Specifications				Characterization Voltages (V_{NOM})				Interface	Package	ECCN Code
		R_{ON} (Ω) (typ)	On Leakage (nA) (typ)	Q_{INJ} (pC) (typ)	BW (MHz)	Single			Dual			
						1.65 to 3.6	2.7 to 5.5	1.8 to 5.5	± 2.5			
ADG849	SPDT \times 1	0.5	0.04	50	38			•		Parallel	SC70	EAR99
ADG852	SPDT \times 1	0.8	0.03	30	100			•		Parallel	LFCSP	EAR99
ADG719	SPDT \times 1	2.5	0.01	—	200			•		Parallel	SOT,* MSOP	EAR99
ADG749	SPDT \times 1	2.5	0.01	—	200			•		Parallel	SC70	EAR99
ADG779	SPDT \times 1	2.5	0.01	2	200			•		Parallel	SC70	EAR99
ADG752	SPDT \times 1	15	0.01	—	250			•		Parallel	SOT, MSOP	EAR99
ADG884	SPDT \times 2	0.28	0.2	125	18			•		Parallel	LFCSP, MSOP, WLCSP	EAR99
ADG824	SPDT \times 2	0.5	0.2	27	90	•				Parallel	LFCSP	EAR99
ADG836/ADG836L	SPDT \times 2	0.5	0.2	40	57	•				Parallel	LFCSP, MSOP	EAR99
ADG854	SPDT \times 2	0.8	0.03	30	100			•		Parallel	LFCSP	EAR99
ADG736/ADG736L	SPDT \times 2	2.5	0.01	—	200			•		Parallel	MSOP	EAR99
ADG787	SPDT \times 2	2.5	0.05	14	145			•		Parallel	LFCSP, MSOP, WLCSP	EAR99
ADG772	SPDT \times 2	6.7	0.2	0.5	630	•				Parallel	LFCSP	EAR99
ADG733	SPDT \times 3	2.5	0.01	3	160			•	•	Parallel	TSSOP, QSOP	EAR99
ADG786	SPDT \times 3	2.5	0.01	3	160			•	•	Parallel	LFCSP	EAR99
ADG858	SPDT \times 4	0.58	0.01	45	70			•		Parallel	LFCSP	EAR99
ADG774	SPDT \times 4	2.2	0.01	7	240			•		Parallel	SOIC, QSOP	EAR99
ADG784	SPDT \times 4	2.2	0.01	10	240			•		Parallel	LFCSP	EAR99
ADG774A	SPDT \times 4	2.2	0.001	6	400			•		Parallel	LFCSP, QSOP	EAR99
ADG734	SPDT \times 4	2.5	0.01	3	160			•	•	Parallel	TSSOP	EAR99
ADG788	SPDT \times 4	2.5	0.01	3	160			•	•	Parallel	LFCSP	EAR99
ADG794	SPDT \times 4	5	0.001	6	300		•			Parallel	QSOP	EAR99
ADG888	DPDT \times 2	0.4	0.2	70	29			•		Parallel	TSSOP, LFCSP, WLCSP	EAR99
ADG804	4:1 mux	0.5	0.1	28	33	•				Parallel	MSOP	EAR99
ADG704	4:1 mux	2.5	0.01	3	200			•		Parallel	MSOP	EAR99
ADG728/ADG729	8:1 diff, 4:1 mux	2.5	0.01	3	65/100		•			I ² C	TSSOP	EAR99
ADG738/ADG739	8:1 diff, 4:1 mux	2.5	0.01	3	65/100		•			SPI	TSSOP	EAR99
ADG708/ADG709	8:1 diff, 4:1 mux	3	0.01	3	55			•	•	Parallel	TSSOP	EAR99
ADG758/ADG759	8:1 diff, 4:1 mux	3	0.01	3	55			•	•	Parallel	LFCSP	EAR99
ADG706/ADG707	16:1 diff, 8:1 mux	2.5	0.01	5	25/36			•	•	Parallel	TSSOP	EAR99
ADG726/ADG732	32:1 diff-dual, 16:1 mux	4	0.05	5	34/18			•	•	Parallel	LFCSP, TQFP	EAR99
ADG725/ADG731	32:1 diff-dual, 16:1 mux	4	0.05	5	34/18			•	•	SPI	TSSOP, LFCSP, TQFP	EAR99

*Enhanced product switch available in addition to standard switch for specific package.

High Temperature

Part Number	Configuration	Temperature Range	Specifications				Characterization Voltages (V_{NOM})						Interface	Package	ECCN Code	
			R_{ON} (Ω) (max)	On Leakage (nA) (max)	Q_{INJ} (pC)	BW (MHz)	Single				Dual					
							3	5	12	36	± 2.5	± 15				± 20
ADG798 <i>New</i>	8:1 mux	-55°C to +210°C	10	2600	3	55	•	•			•			Parallel	Ceramic flatpack, ceramic flatpack RFG	EAR99
ADG5298 <i>New</i>	8:1 mux	-55°C to +210°C	400	70	0.2	110			•	•		•	•	Parallel	Ceramic flatpack, ceramic flatpack RFG	EAR99

Temperature Sensors

ADT7420/ADT7320: $\pm 0.25^\circ\text{C}$ Accurate, 16-Bit Digital Temperature Sensor

Key Features

- ▶ **ADT7420:** I²C
- ▶ **ADT7320:** SPI
- ▶ Industry-leading accuracy; max accuracy range: -20°C to $+105^\circ\text{C}$
- ▶ Operating temperature range: -40°C to $+150^\circ\text{C}$
- ▶ 16-bit temperature resolution: 0.0078°C
- ▶ No calibration required
- ▶ No self heating or linearity correction required
- ▶ Power saving mode (1 SPS)
- ▶ Critical temperature indicator
- ▶ Over/undertemperature interrupt
- ▶ 16-lead LFCSP RoHS compliant package

Benefits

- ▶ Fully integrated digital temperature measurement solution
- ▶ Easy implementation with digital interface (SPI/I²C), no temperature calibration or correction required by user
- ▶ Excellent long-term stability and reliability—no resistance, noise, or batch variation issues

Applications

- ▶ RTD and thermistor replacement
- ▶ Medical equipment
- ▶ Cold junction compensation
- ▶ Industrial control and test
- ▶ Food transportation and storage
- ▶ Environmental monitoring and HVAC

V _{RANGE}	Active Current	Shutdown Current	Interface	Package	T _{RANGE}
2.7 V to 5.5 V	210 μA (typ)	2 μA (typ)	SPI/I ² C	4 mm \times 4 mm LFCSP	-40°C to $+150^\circ\text{C}$

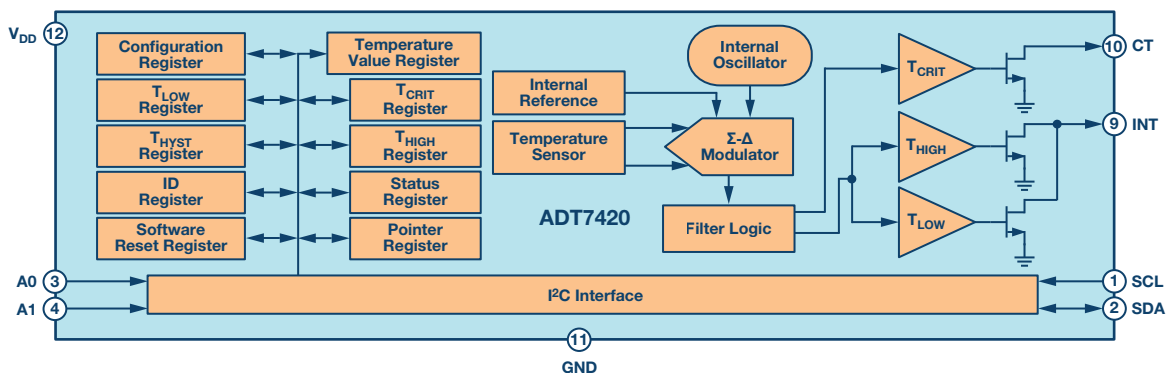

Temperature Sensors

Analog Output

Part Number	Interface	Function/Resolution	Max Accuracy	Operating Range (°C)	Supply Range (V)	Max Current	Packages	Features	ECCN Code
ADT5912 <i>Coming Soon</i>	Voltage output	10 mV/K	±0.1°C @ -20°C to +90°C	-40 to +125	-4.75 to +5.2	-2 mA	4-lead LFCSP	2-terminal temperature transducer	EAR99
AD590	Current output	1 µA/K	±1.0°C @ -55°C to +150°C	-55 to +150	4 to 30	298.2 µA	TO-52, 2-lead FP, 8-lead SOIC, die, 4-lead LFCSP	2-terminal temperature transducer	EAR99
AD592	Current output	1 µA/K	±1.0°C @ -25°C to +105°C	-25 to +105	4 to 30	298.2 µA	TO-92, die	2-terminal temperature transducer	EAR99
TMP35/TMP36	Voltage output	10 mV/°C	±2°C @ 25°C	-40 to +125	2.7 to 5.5	50 µA	TO-92, 5-lead SOT-23, 8-lead SOIC	Voltage output, wide temperature range	EAR99
TMP37	Voltage output	20 mV/°C	±2°C @ 25°C	5 to 100	2.7 to 5.5	50 µA	TO-92, 5-lead SOT-23, 8-lead SOIC	Voltage output, limited temperature range	EAR99
AD22100	Voltage output	22.5 mV/°C	±2°C @ -50°C to +150°C	-50 to +150	4 to 6.5	650 µA	TO-92, 8-lead SOIC, die	Ratiometric sensor	EAR99
AD22103	Voltage output	28 mV/°C	±2.5°C @ 0°C to 100°C	0 to 100	2.7 to 3.6	600 µA	TO-92, 8-lead SOIC	Ratiometric sensor	EAR99
LTC2997	Voltage output	4 mV/K	±1°C @ 0°C to 100°C	-40 to +125	2.5 to 5.5	250 µA	6-lead LFCSP	Voltage output, internal/external temperature sensor	EAR99

Digital Output

Part Number	Interface	Function/Resolution	Max Accuracy	Operating Range (°C)	Supply Range (V)	Max Current	Packages	Features	ECCN Code
ADT7422 <i>Coming Soon</i>	I ² C/SMBus	16-bit local	±0.1°C @ 37°C to 39°C	-40 to +150	2.7 to 5.5	270 µA	16-lead LFCSP	16-bit digital temperature sensor, critical temperature indicator, programmable interrupt	EAR99
ADT7420	I ² C/SMBus	16-bit local	±0.25°C @ -20°C to +105°C	-40 to +150	2.7 to 5.5	270 µA	16-lead LFCSP	16-bit digital temperature sensor, critical temperature indicator, programmable interrupt	EAR99
ADT7320	SPI	16-bit local	±0.25°C @ -20°C to +105°C	-40 to +150	2.7 to 5.5	270 µA	16-lead LFCSP	16-bit digital temperature sensor, critical temperature indicator, programmable interrupt	EAR99
ADT7410	I ² C/SMBus	16-bit local	±0.5°C @ -40°C to +105°C	-55 to +150	2.7 to 5.5	270 µA	8-lead SOIC, 16-lead LFCSP	16-bit digital temperature sensor, critical temperature indicator, programmable interrupt	EAR99
ADT7310	SPI	16-bit local	±0.5°C @ -40°C to +105°C	-55 to +150	2.7 to 5.5	270 µA	8-lead SOIC, 16-lead LFCSP	16-bit digital temperature sensor, critical temperature indicator, programmable interrupt	EAR99
ADT7311	SPI	16-bit local	±0.5°C @ -40°C to +105°C	-55 to +150	2.7 to 5.5	270 µA	8-lead SOIC	Automotive qualified, 16-bit digital temperature sensor	EAR99
ADT7312	SPI	16-bit local	±1°C @ -40°C to +175°C	-55 to +175	2.7 to 5.5	350 µA	Die form	Automotive qualified, 16-bit digital temperature sensor	EAR99
ADT75	I ² C/SMBus	12-bit local	±1°C @ 0°C to 70°C	-55 to +125	2.7 to 5.5	525 µA	8-lead SOIC, 8-lead MSOP	12-bit digital temperature sensor	EAR99
ADT7301	SPI	13-bit local	±1°C @ 0°C to 70°C	-40 to +150	2.7 to 5.25	1.6 mA	6-lead SOT-23, 8-lead MSOP	13-bit digital temperature sensor	EAR99
ADT7302	SPI	13-bit local	±2°C @ 0°C to 70°C	-40 to +150	2.7 to 5.25	1.6 mA	6-lead SOT-23, 8-lead MSOP	13-bit digital temperature sensor	EAR99
TMP05/TMP06	PWM	0.025°C resolution	±1°C @ 0°C to 70°C	-40 to +150	2.7 to 5.5	0.6 mA	5-lead SC70, 5-lead SOT-23	Open-drain, push-pull, daisy-chain mode, one shot mode	EAR99
AD7414/AD7415	I ² C/SMBus	10-bit local	±1.5°C @ -40°C to 70°C	-40 to +125	2.7 to 5.5	0.1 mA	6-lead SOT-23, 5-lead SOT-23, 8-lead MSOP	10-bit digital temperature sensor, supports SMBus alert function	EAR99
AD7814	SPI	10-bit local	±2°C @ 0°C to +85°C	-55 to +125	2.7 to 5.5	400 µA	6-lead SOT-23	10-bit digital temperature sensor	EAR99
ADT7408	I ² C/SMBus	10-bit local	±3°C @ 40°C to +125°C	-20 to +125	3 to 3.6	550 µA	8-lead LFCSP	12-bit digital temperature sensor	EAR99
TMP03/TMP04	PWM	0.1°C/LSB	±4°C @ -20°C to +100°C	-40 to +150	4.5 to 7	1.3 mA	TO-92, 8-lead SOIC, 8-lead TSSOP	Open collector, CMOS/TTL-compatible output	EAR99

Temperature Sensors

Trip Point

Part Number	Interface	Function/Resolution	Max Accuracy	Operating Range (°C)	Supply Range (V)	Max Current (μA)	Packages	Features	ECCN Code
ADT6501/ADT6503	Factory set	10°C increments	±4°C @ -15°C to +15°C	-55 to +125	2.7 to 5.5	50	5-lead SOT-23	Factory set over/undertemperature indicators; open-drain output	EAR99
ADT6502/ADT6504	Factory set	10°C increments	±4°C @ -15°C to +15°C	-55 to +125	2.7 to 5.5	50	5-lead SOT-23	Factory set over/undertemperature indicators; push-pull output	EAR99
ADT6401	Pin selectable	10°C increments	±4°C @ -15°C to +15°C	-55 to +125	2.7 to 5.5	50	6-lead SOT-23	Pin set over/undertemperature indicators; open-drain output	EAR99
ADT6402	Pin selectable	10°C increments	±4°C @ -15°C to +15°C	-55 to +125	2.7 to 5.5	50	6-lead SOT-23	Pin set over/undertemperature indicators; push-pull output	EAR99
TMP01	Resistor programmable	Voltage output (5 mV/K)	±1.5°C @ 25°C	-55 to +125	4.5 to 13.2	500	8-lead SOIC, 8-lead PDIP	Resistor programmable window comparator; voltage output	EAR99

Integrated Digital Output with DACs/ADCs/Both

Part Number	Interface	Function/Resolution	Max Accuracy	Operating Range (°C)	Supply Range (V)	Max Current (mA)	Packages	Features	ECCN Code
AD7417	I ² C/SMBus	10-bit local	±1°C @ 25°C	-40 to +125	2.7 to 5.5	0.6	16-lead SOIC, 16-lead TSSOP	4-channel, external, 10-bit ADC input and temperature sensor	EAR99
AD7418	I ² C/SMBus	10-bit local	±1°C @ 25°C	-40 to +125	2.7 to 5.5	0.6	8-lead SOIC, 8-lead MSOP	1-channel, external, 10-bit ADC input and temperature sensor	EAR99
AD7817	SPI	10-bit local	±1°C @ 25°C	-55 to +125	2.7 to 5.5	2	16-lead SOIC, 16-lead TSSOP	4-channel, external, ADC input and temperature sensor	EAR99
AD7818	SPI	10-bit local	±2°C @ 25°C	-55 to +125	2.7 to 5.5	2	8-lead SOIC, 8-lead MSOP	1-channel, external, ADC input and temperature sensor	EAR99
ADT7516	SMBus/SPI	10-bit local and 10-bit remote	±2°C @ 0°C to +85°C	-40 to +125	2.7 to 5.5	3	16-lead QSOP	12-bit, quad DAC; 10-bit, 4-channel ADC; 10-bit temperature sensors	EAR99
ADT7411	SMBus/SPI	10-bit local	±3°C @ 0°C to +85°C	-40 to +125	2.7 to 5.5	3	16-lead QSOP	10-bit, 8-channel ADC with 10-bit local and remote temperature sensors	EAR99
ADT7316	SMBus/SPI	10-bit local	±3°C @ 0°C to +85°C	-40 to +125	2.7 to 5.5	3	16-lead QSOP	12-bit, quad DAC with 10-bit local and remote temperature sensors	EAR99

Fan Controllers

Part Number	Interface	Function/Resolution	Max Accuracy	Operating Range (°C)	Supply Range (V)	Max Current	Packages	Features	ECCN Code
ADT7470	I ² C/SMBus	PWM fan control	Connects to TMP05/TMP06	-40 to +125	3.0 to 5.5	0.8 mA	16-lead QSOP	4-channel PWM fan control using TMP05/TMP06 temperature sensor	EAR99

Sensor Interface Signal Chain Solutions

Battery Formation and Testing

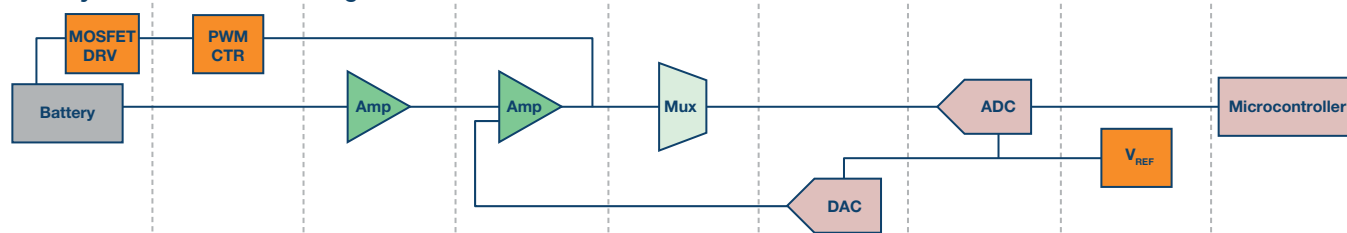

		Voltage and Current Sensing	Loop Control					
ADuM7223	ADP1972	AD8221/ AD8226	ADA4177	ADG52xxF	AD5689R	AD7173/ AD7175	LT6657	Blackfin®
	ADP1974	LT6015	LTC2057	ADG12xx	AD5360	AD7124	LTC6655	
		AD8276	ADTL082		AD5371	AD7779	ADR44x	
		ADA8479	ADA4522				ADR45xx	
		LTC6375/ LTC6376					LTC6652	
		LT1997-3/ LT1997-2/ LT1997-1						
		AD8450						
		AD8451						
		AD8452						

Biopotential Sensing

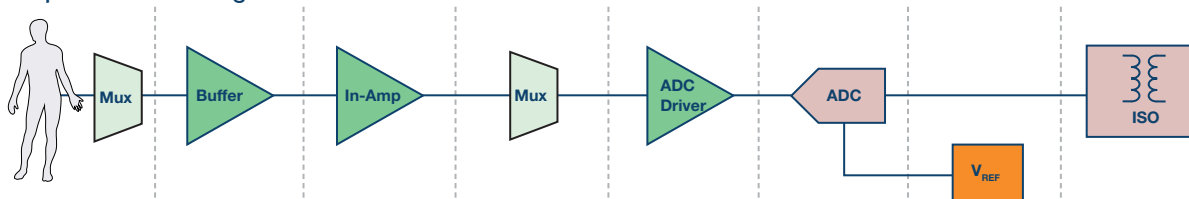

ADG1204	AD8244	AD8237	ADG1204	ADA4522	AD7982	LT6657	ADuM440x	ECG/EEG/EMG Discrete and Core Technology
ADG1436	AD8606	AD8235	ADG1436	AD8475	AD7960	ADR43xx		
	ADA4661	AD8422		LTC6363	AD7091	LTC6652		
	LTC6240/ LTC6244	AD8226			AD4001			
	LTC6078/ LTC6081	AD8220			LTC2387/ LTC2386/ LTC2385			
		LT6370			LTC2378			
		AD8232						Integrated Solutions
		AD8233						
		ADAS1000						

Sensor Interface Signal Chain Solutions

Current Sensing—Medium Voltage Rail Shunts

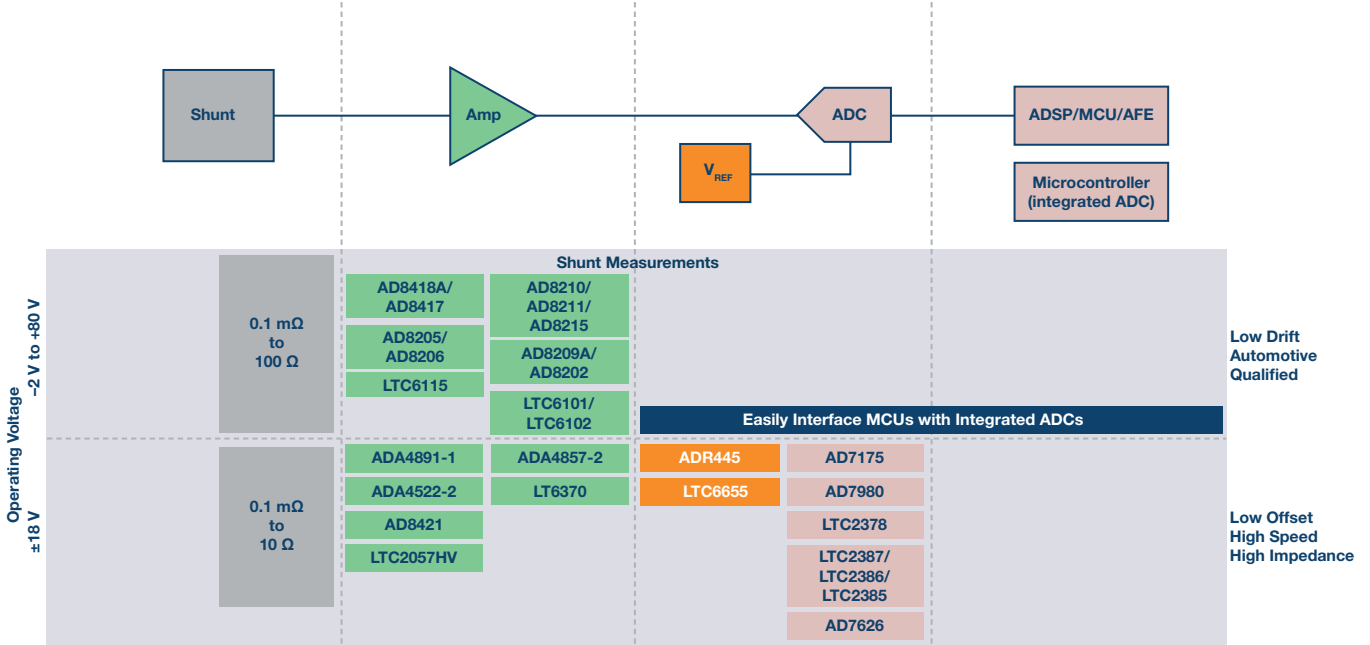

Current Sensing—High Voltage Rail Shunts

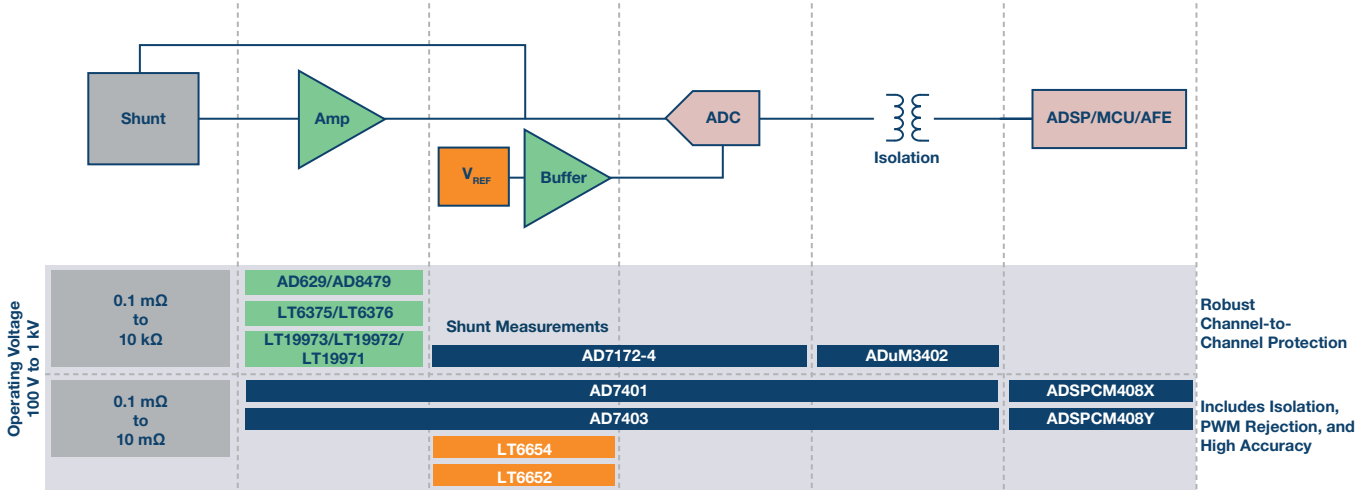

Sensor Interface Signal Chain Solutions

Current Sensing—Contactless Current Measurement

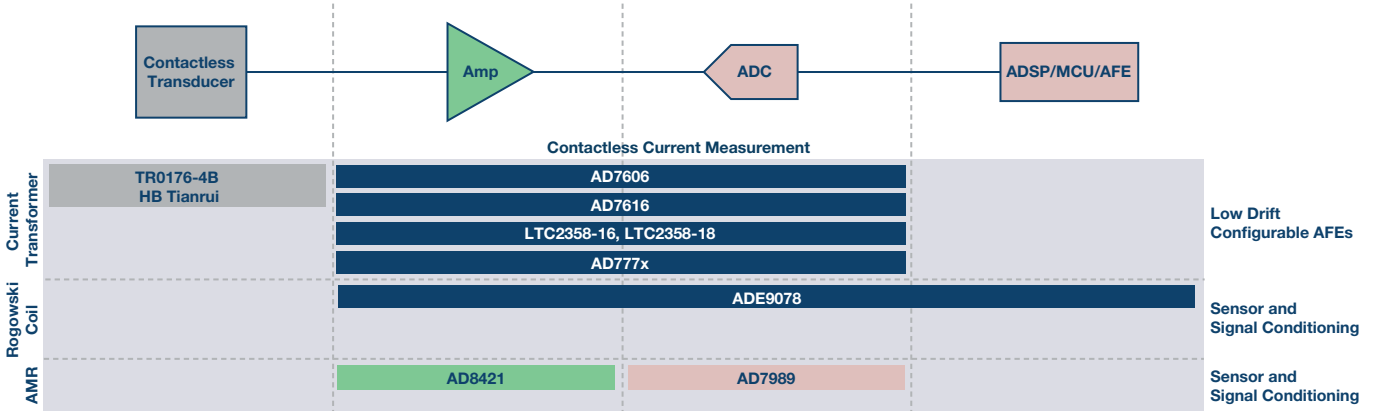

Position Sensing—Optical Encoders

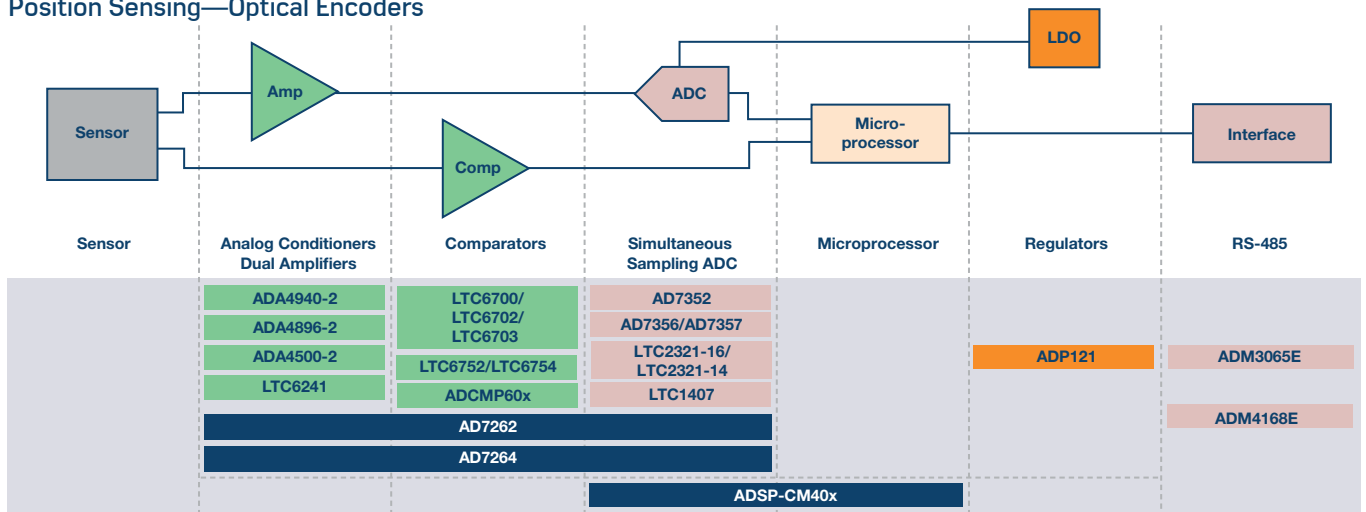

Sensor Interface Signal Chain Solutions

Position Sensing—Resolver and LVDT

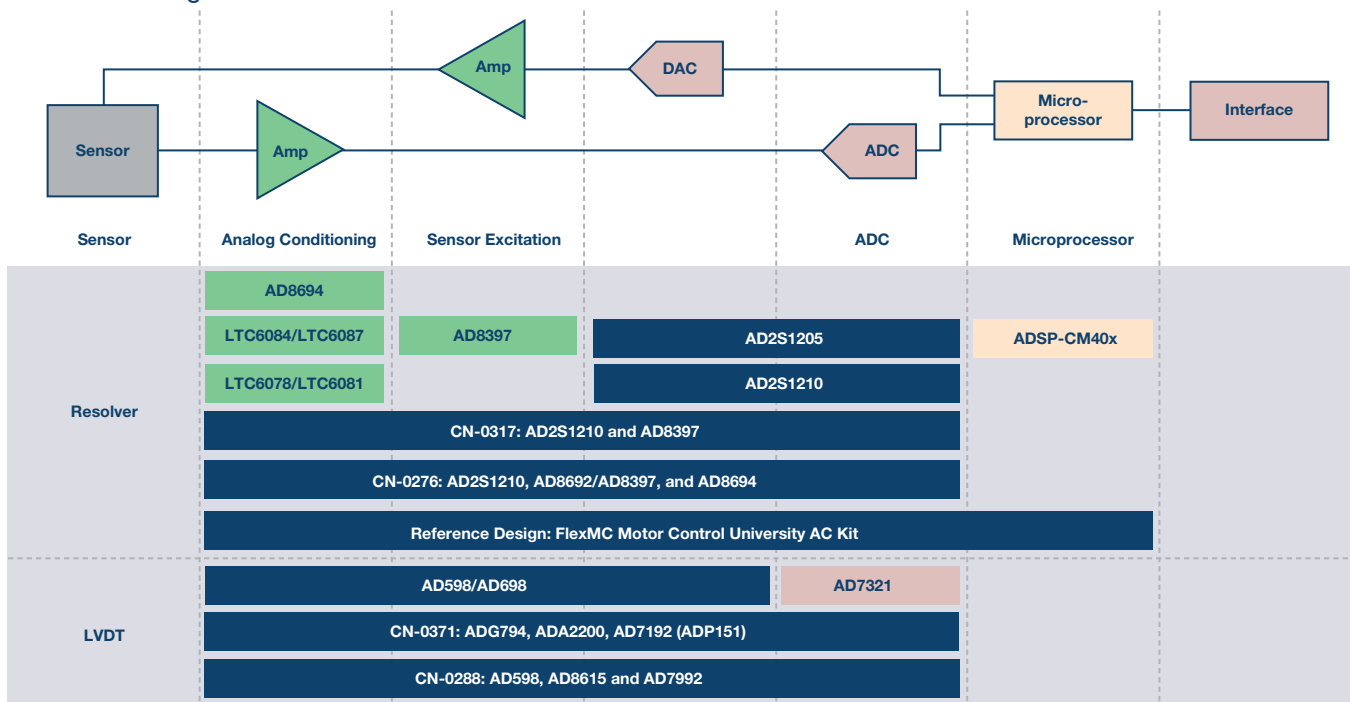

Position Sensing—AMR and TMR

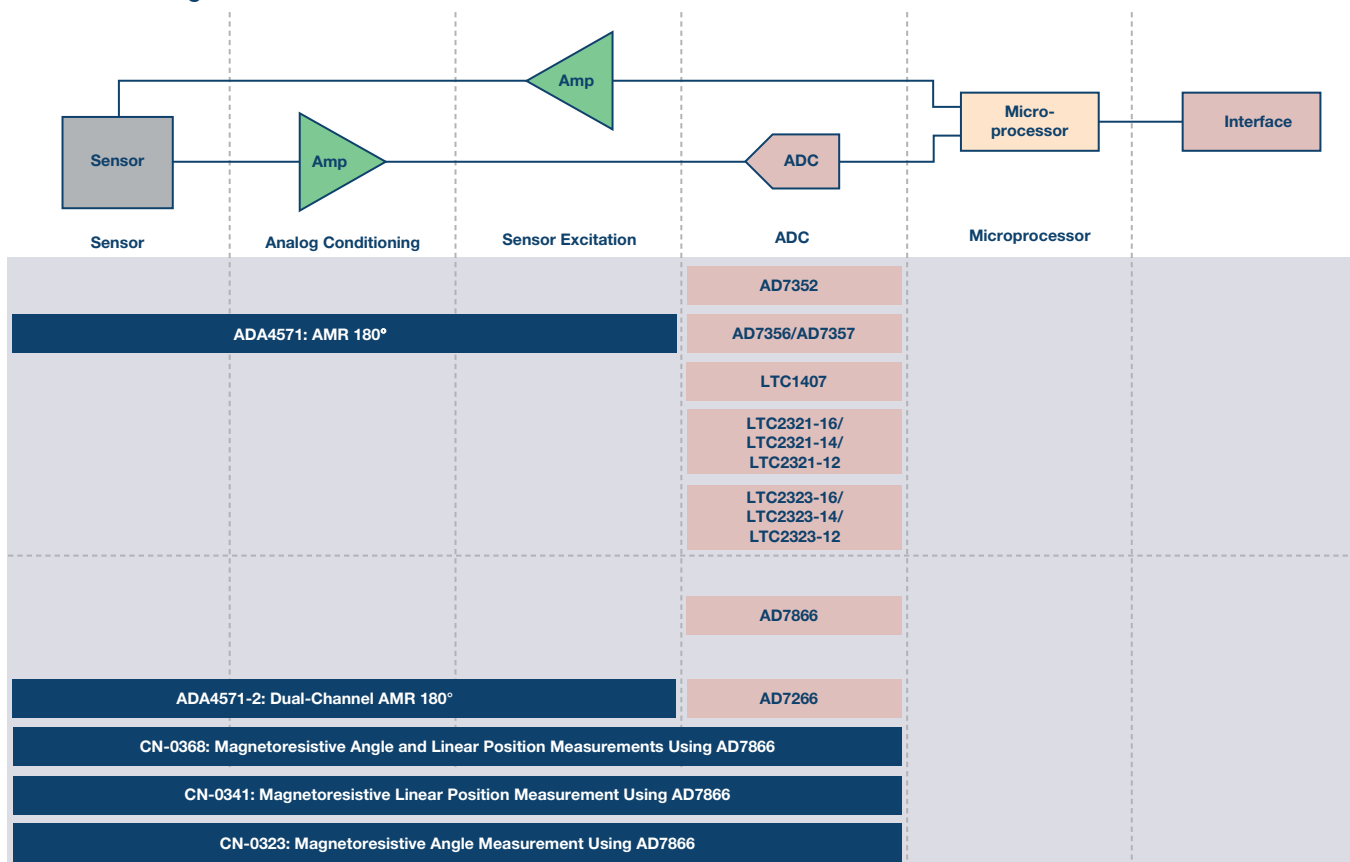

Sensor Interface Signal Chain Solutions

Temperature Sensing—Thermocouples (TC)

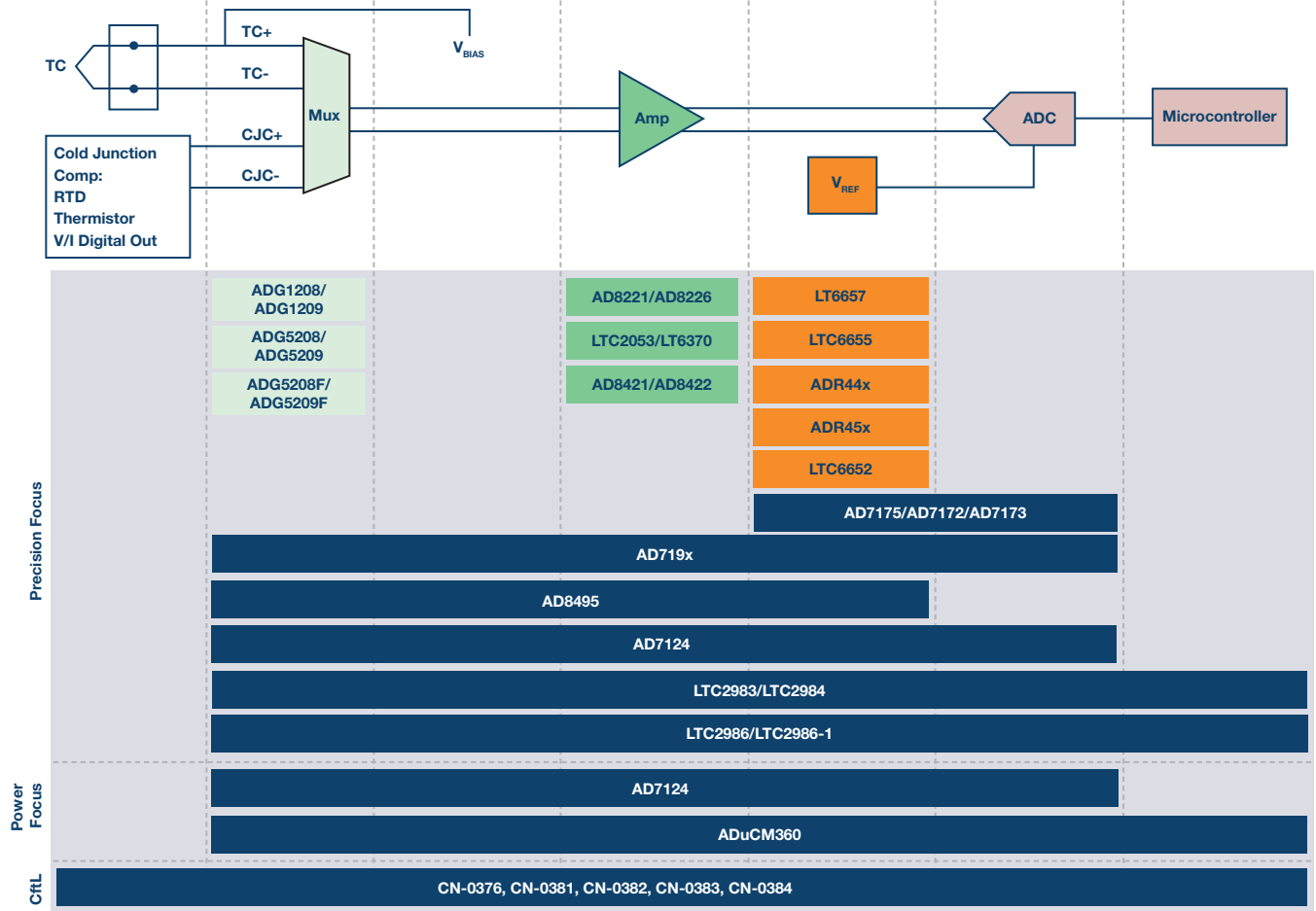

Sensor Interface Signal Chain Solutions

Temperature Sensing—Resistive Thermal Devices (RTD)

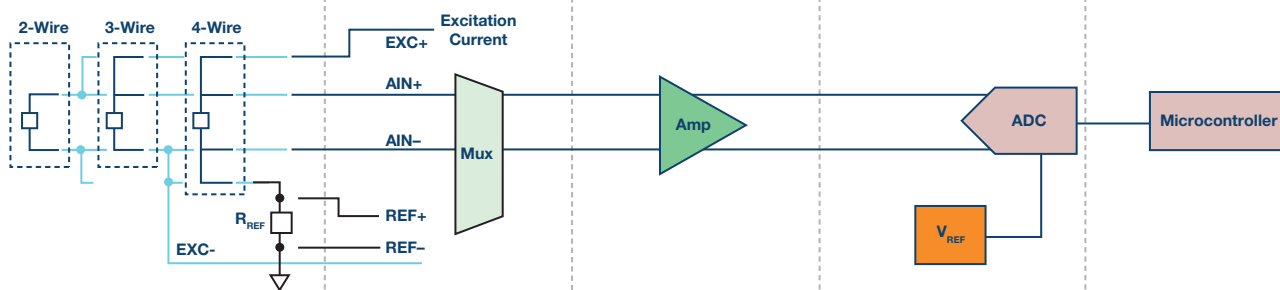

Precision Focus	ADG1208/ ADG1209	ADA4096/LT6015	LT6657
	ADG5208/ ADG5209	ADA4500	LTC6655
	ADG5208F/ ADG5209F	ADA4522	ADR44x
		AD8221/AD8226	ADR45xx
		AD8421/AD8422	LTC6652
		LTC2053/LT6370	
		AD719x	
		AD8495	
		AD7124	
	Power Focus	LTC2983/LTC2984	
LTC2986/LTC2986-1			
AD7124			
ADuCM360			
CofL	CN-0376, CN-0381, CN-0382, CN-0383, CN-0384		

Sensor Interface Signal Chain Solutions

Temperature Sensing—Thermistors

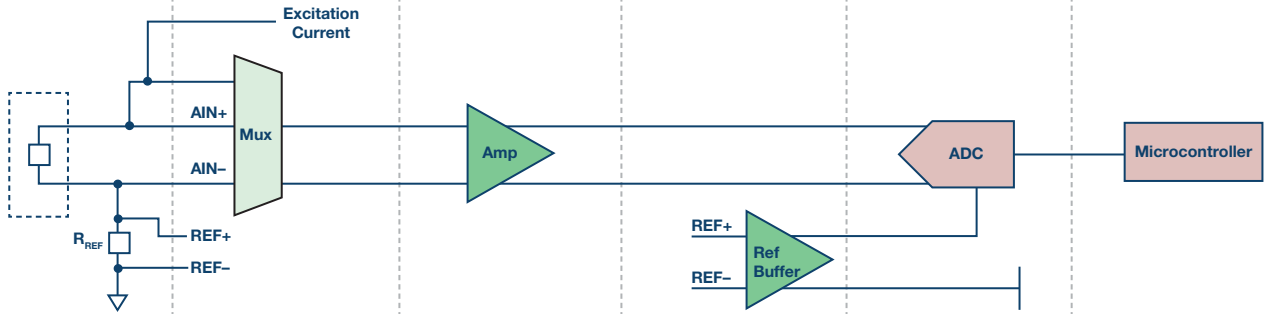

	ADG1208/ADG1209	ADA4096	ADA4805
	ADG5208/ADG5209	ADA4500	ADA4807
	ADG5208F/ADG5209F	ADA4522	AD7175/AD7172/AD7173
Precision Focus		AD8221/AD8226	
		AD8421/AD8422	
		LTC2053/LT6370	
		AD719x	
		AD8495	
Power Focus		AD7124	
		LTC2983 /LTC2984	
		LTC2986/LTC2986-1	
CnT		AD7124	
		ADuCM360	
	CN-0376, CN-0381, CN-0382, CN-0383, CN-0384		

Sensor Interface Signal Chain Solutions

Temperature Sensing—Diodes

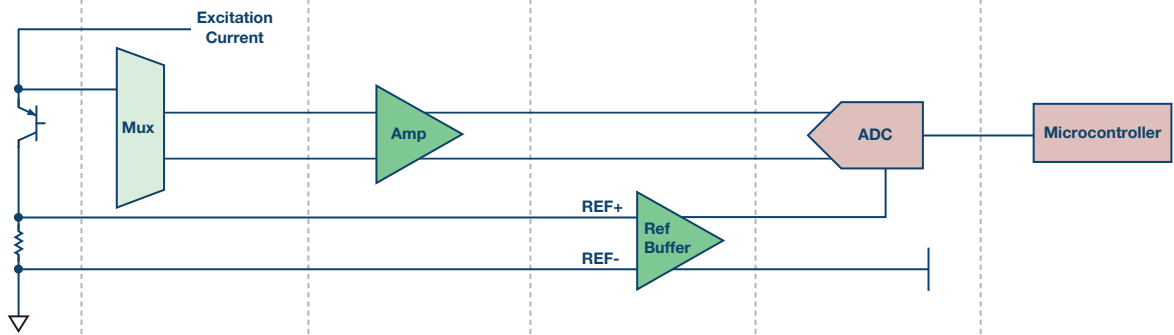

	Mux	Amp	Ref Buffer	ADC	Microcontroller	
Precision Focus	ADG1208/ADG1209	ADA4096		ADA4805		
	ADG5208/ADG5209	ADA4500		ADA4807		
	ADG5208F/ADG5209F	ADA4522		AD7175/AD7172/AD7173		
		AD8221/AD8226				
		AD8421/AD8422				
		LTC2053/LT6370				
		AD719x				
		AD8495				
		AD7124				
		LTC2983/LTC2984				
	LTC2986/LTC2986-1					
Power Focus	AD7124					
	ADuCM360					
CofL	CN-0376, CN-0381, CN-0382, CN-0383, CN-0384					

Sensor Interface Signal Chain Solutions

Temperature Sensing—Silicon Sensors

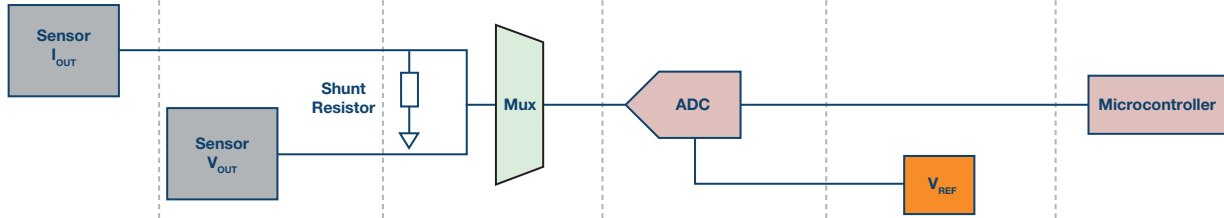

	AD590	ADG1208/ADG1209		
	ADT5910	ADG5208/ADG5209		
Precision Focus		ADG5208F/ADG5209F	AD7980	LT6657
		AD7175		LTC6655
			AD7124	ADR44x
			AD719x	ADR45xx
	ADT5912			LTC6652
VSM Focus (Narrow Temp Range)	ADT7320			
	ADT7420			
	ADT7422			
High Temp		ADuCM360		
		ADG5298	AD7981	ADR225
		ADG798		LT6654x

Chemical Analysis—Spectroscopy 1: Modulated, Pulsed Light Source, Wider Bandwidth, Smaller Area PD

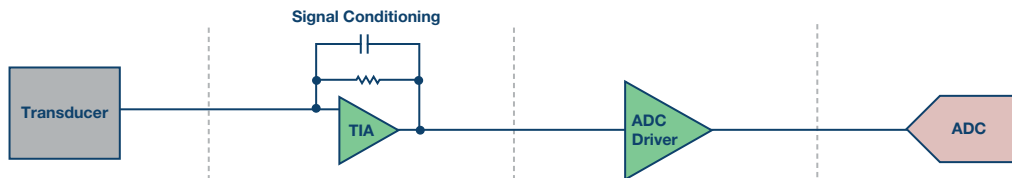

	ADPD103/ADPD105/ADPD107 LED Driver, TIA, Sync Demodulator, and 14-Bit ADC			
Modulated, Pulsed Light Source, Wider Bandwidth, Smaller Area PD	AD8605/AD8606/AD8608 5 V Prec RRIO, 10 MHz, 1 V/μs, 1 pA, 1.2 mA	Demodulator	AD4000/AD4002/AD4004 SAR 2 MSPS, 1 MSPS, 16-/18-Bit SE LTC2370/LTC2369/LTC2368	
	LT6240: 5 V Prec RRO 18 MHz, 10 V/μs, 1 pA, 2.4 mA	ADC Driver Drive Direct in High-Z Mode →	ADAQ7980 (1 MSPS) μModule® Data Acquisition System	
	AD8615/AD8616/AD8618 5 V Prec RRIO, 20 MHz, 12 V/μs, 1 pA, 2.5 mA	ADA4807 3.1 nV/√Hz, 180 MHz, 1 mA, RRIO	AD7988-1, AD7988-5 100 kSPS/500 kSPS SAR	
	LTC6244 5 V Prec RRO 50 MHz, 35 V/μs, 7.4 mA	LTC6246 4.2 nV/√Hz, 180 MHz, 0.95 mA, RRIO, Low I _{BIAS}	LTC2370/LTC2369/LTC2368 SAR 2 MSPS, 1 MSPS, 16-/18-Bit SE	
	ADA4350 12 V, 175 MHz, Programmable TIA and ADC Driver			
AC Measurement				
Solutions and Reference Designs	Colorimeter: CN-0363, CN-0312			

Color

Sensor Interface Signal Chain Solutions

Chemical Analysis—Spectroscopy 2: DC Photodiode, Low Light, High DR, Large Area PD

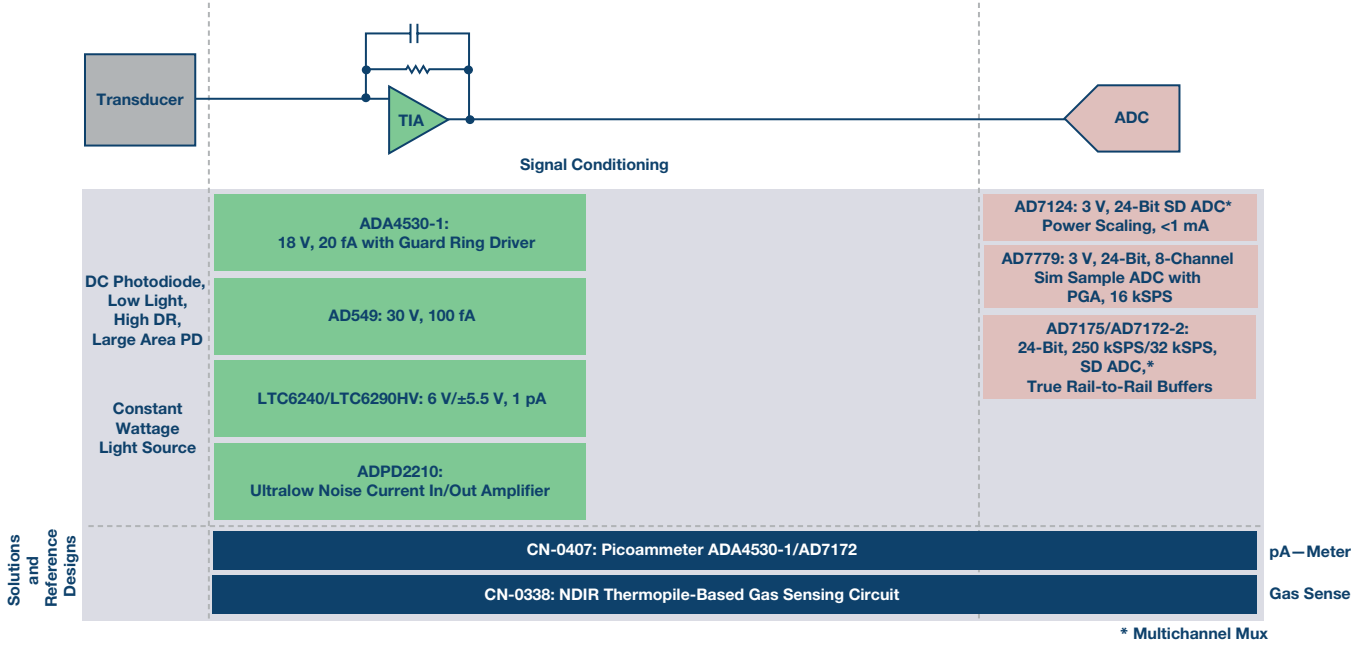

Chemical Analysis—Spectroscopy 2: Photomultipliers

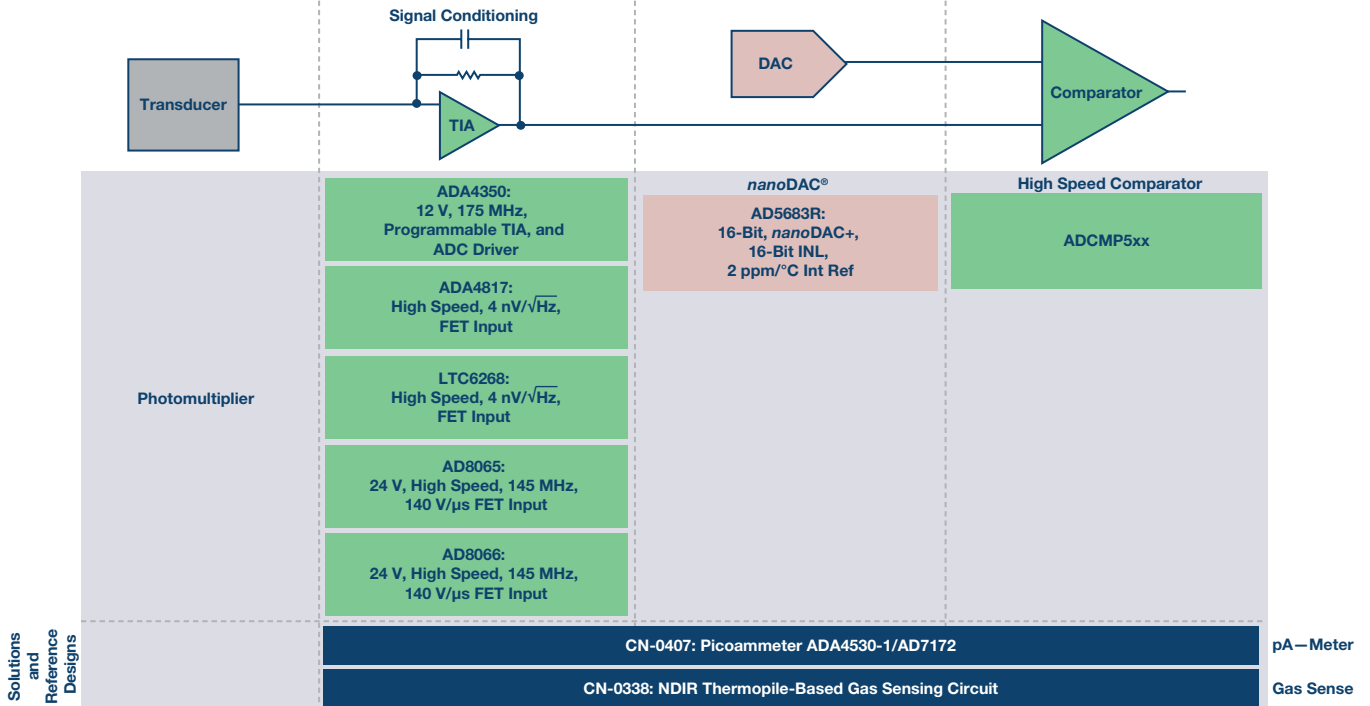

Sensor Interface Signal Chain Solutions

Chemical Analysis—Charged Particle Beams

Solutions and Reference Designs	Charged Coupled Display (CCD)	ADA4896/ADA4897: 230 MHz, Low Noise, RRIO	ADC Driver	ADAQ7980: (1 MSPS) μModule Data Acquisition System	ADC
		ADA4800: 400 MHz Low Power CCD Buffer		ADA4945-1: 1.6 nV/√Hz, 1.4 mA, 145 MHz Diff Amp	
		LTC6253: 720 MHz, Low Noise, RRIO		LTC6403: Diff Amp 200 MHz, 2.8 nV/√Hz	AD7677: SAR 2.5 MSPS, 16-Bit Differential Input
		ADA4807: 180 MHz, Low Noise, RRIO		LTC6363: Diff Amp 500 MHz, 2.9 nV/√Hz	AD7961/LTC2385: SAR 5 MSPS, 16-Bit Differential Input
		LTC6246: 180 MHz, I _{BIAS} 30 nA, RRIO		ADA4932: 3.6 nV/√Hz, 9.6 mA, 560 MHz Diff Amp	AD7988-1, AD7988-5: 100 kSPS/500 kSPS SAR
					AD7626/LTC2386: SAR 10 MSPS, 16-Bit Differential Input
					LTC2387-16/LTC2387-18: SAR 15 MSPS, 16-/18-Bit Differential Input
		CN-0338 NDIR Thermopile-Based Gas Sensing Circuit			Gas Sense

Chemical Analysis—Charged Particle Beams

Solutions and Reference Designs	Faraday Cup	ADA4530-1: 18 V, 20 fA with Guard Ring Driver	Drive Direct in High-Z Mode	AD4000/LTC2370/AD4002/LTC2369/AD4004/LTC2368: SAR 2 MSPS, 1 MSPS, 16-/18-Bit, SE	
		ADA8615/ADA8616/ADA8618: 20 MHz, 1 pA			
		LTC6081: 5 V, 1 pA, 4 MHz			
	Flame Ionization Detector	ADA4530-1: 18 V, 20 fA with Guard Ring Driver		AD7175/AD7172-2: 24-Bit, 250 kSPS/32 kSPS, SD ADC, * True Rail-to-Rail Buffers	
		AD549: 30 V, 100 fA		AD7124: Power Scaling, Low Power, 3 V, 24-Bit, SD ADC*	
				AD7190: 24-Bit, SD 4.8 kSPS Low Noise, PGA (1 to 128)	
		CN-0407: Picoammeter ADA4530-1/AD7172			pA—Meter

*Multichannel Mux

Sensor Interface Signal Chain Solutions

Chemical Analysis—Charged Particle Beams: Electron Multipliers

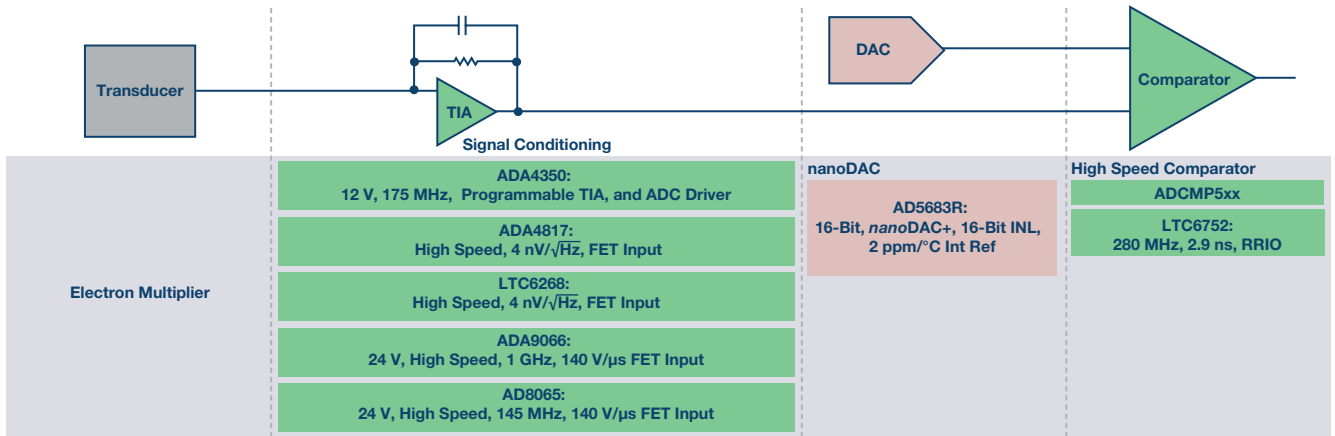

Chemical Analysis—Electrochemical Cell

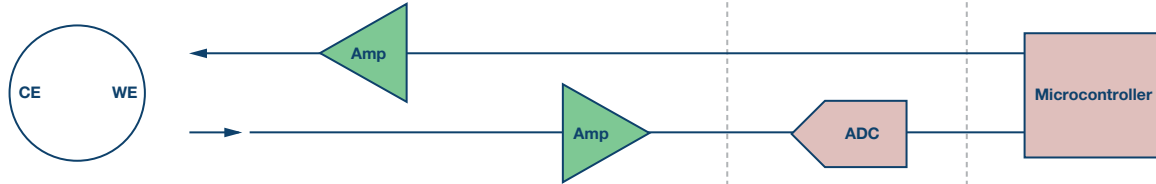

Electrochemical Cell Interface	EC Cell Health: Impedance Diagnostic		Low Power		Microcontroller	
	AD5933: 1 MSPS Impedance Network Analyzer	AD8500/AD8502/AD8504: 1.8 V to 5 V, RRIO 1 μA, 10 pA	ADA4051: 1.8 V to 5 V, ZD, 17 μA, RRIO	AD7170/AD7171: 12-/16-Bit SD Low Power, 135 μA		ADuCM3029: ULP 30 μA/MHz ARM® Cortex®-M3 MCU
	AD5541A: Low Noise, 16-Bit DAC	ADA4505: 1.8 V to 5 V, ZCO, RRIO 10 μA, 2 pA	LTC2063 1.7 V to 5 V, ZD, 2 μA, RRIO	AD7790: 16-Bit, SD Low Power, 75 μA		
	Low Power Reference	AD8603/AD8607/AD8609: 1.8 V to 5 V, Prec RRIO, 50 μA, 1 pA	LTC2066 1.7 V to 5 V, ZD, 10 μA, RRIO	AD7798: 16-Bit, SD with PGA 380 μA		
	REF19x: Low Tempco, 45 μA V _{REF}	ADA4691-2/ADA4692: 5 V, 16 nV/√Hz SD pin, 200 μA, 5 pA	Low Noise	AD7124-4/AD7124-8: 3 V, 24-Bit SD 255 μA Low Power Mode		
	ADR34xx/ADR35xx: 85 μA V _{REF}	LTC6081 5V, 13 nV/√Hz, RRIO, 400 μA, 1 pA	ADA4528: ZD, RRIO, 5.6 nV/√Hz			
LT6656: 1 μA V _{REF}						
Solutions and Reference Designs	AD5940					
	ADuCM355					
	CN-0359, CN-0349: Fully Automatic, High Performance Conductivity Measurement System, Isolated Conductivity DAQ					Conductivity
	CN-0324, CN-0357: Toxic Gas Monitors, CN-0338: CO2 Gas Sensor, CN-0396: Dual EC Cell Gas Sensor with Temp Compensation					Gas Sense
CN-0346: Relative Humidity Measurement System					RH	

Sensor Interface Signal Chain Solutions

Chemical Analysis—Ion Selective Electrodes (pH)

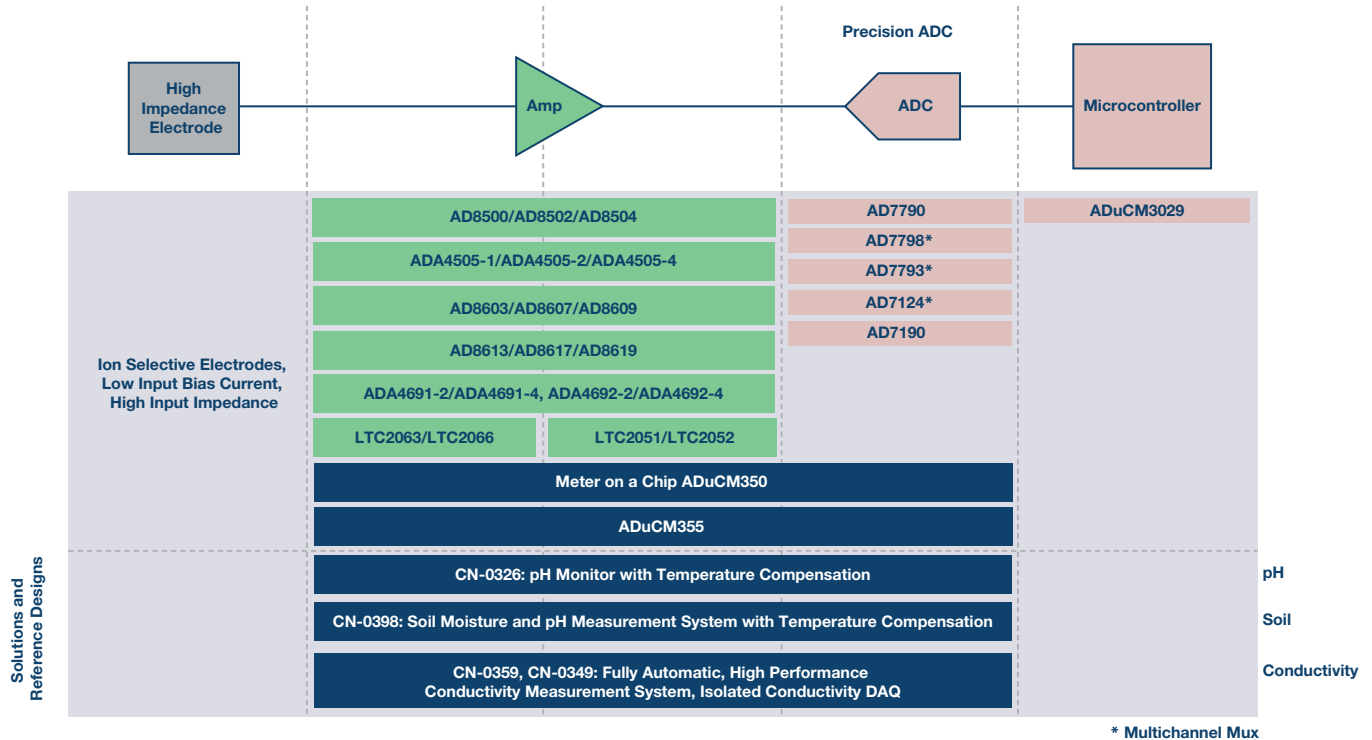

Amplifier and Precision Converter Design Tools

LTspice

LTspice® is a high performance SPICE simulator, schematic capture, and waveform viewer with enhancements and models for easing the simulation of switching regulators. Our enhancements to SPICE have made simulating switching regulators extremely fast compared to normal SPICE simulators, allowing the user to view waveforms for most switching regulators in just a few minutes. Included in this download are LTspice, Macro Models for the majority of ADI's switching regulators, over 200 op amp models, and resistors, transistors, and MOSFET models.

analog.com/en/design-center/design-tools-and-calculators/ltspice-simulator.html

Precision ADC Driver Tool *New*

- ▶ The precision ADC driver tool provides a specialized simulation environment where the engineer can quickly determine the impact of the driver and RC filter selection on the overall system performance of an ADC signal chain.
- ▶ Allows the user to optimize the driver and RC filter choice for their end application requirements and provides an estimate of the impact of the selected driver and RC filter on overall system noise and distortion.
- ▶ Enables the user to simulate the settling of the ADC input for various input scenarios, given the selected driver and RC filter.
- ▶ Allows the user to quickly determine the performance trade-offs between various ADCs and drivers that would otherwise require complex calculations and simulations.

beta-tools.analog.com/adcdriver/

Analog Filter Wizard

Use the Analog Filter Wizard™ to design low-pass, high-pass, or band-pass filters with actual op amps in minutes. As you progress through the design process, you can observe the characteristics of your filter design from ideal specifications to real-world circuit behavior. Quickly evaluate the trade-offs in op amp specifications—including gain bandwidth, noise, and supply current—to determine the best filter design for your requirements.

analog.com/designtools/en/filterwizard/

Analog Photodiode Wizard

Use Photodiode Wizard™ to design a transimpedance amplifier circuit to interface with a photodiode. Select a photodiode from the library included in the tool or enter custom photodiode specifications. Quickly observe trade-offs between bandwidth, peaking (Q), and ENOB/SNR. Modify circuit parameters and immediately see results in plots for pulse response, frequency response, and noise gain.

analog.com/designtools/en/photodiode/

Power Dissipation vs. Die Temperature

This tool estimates die temperature and power dissipation based on the supply voltages, ambient temperature, load characteristics, and package thermal data.

analog.com/en/design-center/interactive-design-tools/power-dissipation-vs-die-temp.html

In-Amp Diamond Plot Tool

The Diamond Plot Tool™ is a web application that generates a configuration-specific output voltage range vs. input common-mode voltage graph, also known as the diamond plot, for Analog Devices instrumentation amplifiers. Based on user inputs such as supply voltage, gain, and input signal range, the tool detects saturation and recommends in-amps for which the input signal is in-range and the configuration is valid. Avoid saturation, find the best in-amp for your design, and save time.

analog.com/designtools/en/diamond/

ADI DiffAmpCalc

ADI's new ADI DiffAmpCalc™ is a free, downloadable calculator for designing differential amplifier circuits. The tool is easy to use and features an interactive user interface to quickly get you up and running.

analog.com/diffampcalc

Difference Amplifier Tools

A collection of tools for calculating performance at the various gains of ADI's pin selectable gain difference amplifiers.

- ▶ LT1991
- ▶ LT1997-2
- ▶ LT1997-3
- ▶ LT6375
- ▶ LT6376

SNR/THD/SINAD Calculator

This calculator converts SNR, THD, and SINAD into ENOBs and noise. It also computes one of SNR, THD, or SINAD from the other two.

analog.com/en/design-center/interactive-design-tools/snr-thd-sinad-calculator.html

Σ - Δ ADC Tutorial

An interactive illustration showing the behavior of an idealized Σ - Δ analog-to-digital converter.

analog.com/en/design-center/interactive-design-tools/sigma-delta-ADC-tutorial.html

LinearLabTools

LinearLabTools is a collection of MATLAB® and Python™ programs that provide direct access to ADI's data converter evaluation boards.

An evaluation board for a data converter will typically plug into an accompanying controller board, which is then connected to a host computer running an LTC supplied GUI program such as PScope for analog-to-digital converters or LTDACgen for digital-to-analog converters. The GUI allows basic performance measurements to be made, but it is not designed to run arbitrary sequences of tests or communicate with other hardware, as is often required by customers when evaluating a part for their own application. LinearLabTools allows customers to control ADI's data converter demo boards as they would any other piece of test equipment, using their own software.

The LinearLabTools package also contains various application examples, simulations, and educational programs that demonstrate mixed-signal concepts.

analog.com/en/design-center/evaluation-hardware-and-software/evaluation-platforms/linearlab-tools.html

Analysis Control Evaluation (ACE) Software

ADI's Analysis, Control, Evaluation (ACE) software is a desktop application that allows for the evaluation and control of multiple evaluation systems, from across ADI's product portfolio. The application consists of a common framework and individual component specific plug-ins.

ACE Evaluation Board Plug-ins

ACE software has a number of plug-ins that are available online.

analog.com/en/design-center/evaluation-hardware-and-software/ace-software.html

Virtual Eval BETA

The virtual evaluation models are visual, interactive web environments that:

- ▶ Allows the user to change silicon parameters (filter type, output data rate, channel count, etc.).
- ▶ Flags out of bounds conditions, ensuring that the configuration being selected/evaluated is an allowed configuration.
- ▶ Shows the performance data provided by the tool (noise, timing, filter response, and settling time effects for multiple channels).

beta-tools.analog.com/virtualeval/

For additional info visit analog.com/en/design-center/design-tools-and-calculators/amplifier-and-linear-tools.html

Design Resources

Circuits from the Lab Reference Designs

Circuits from the Lab reference designs are engineered and tested for quick and easy system integration to help solve today's analog, mixed-signal, and RF design challenges. These circuits represent easy to understand subsystem-level building blocks intended for time-saving evaluation and easy integration. Each reference circuit has been thoroughly documented, and many provide test data, design/layout guidelines, schematics, PCB layout files, bill of materials, device drivers, and evaluation hardware.

Find RF circuits at analog.com/circuits.

**Circuits
from the Lab[®]**
Reference Designs

EngineerZone

EngineerZone is ADI's online support community for engineers using the company's products to ask products, share knowledge, and search for answers to their design questions.

Collaborate with ADI engineers and other designers in this open forum at ez.analog.com.

 **EngineerZone[®]**
SUPPORT COMMUNITY

Authorised Analog Devices Distributor and Test House



www.semitron.de

sales@semitron.de

testhaus@semitron.de

Incoming Goods Inspection



Test House Services



Programming Service



Test Systems



Tape and Reel Service



Semitron W. Röck GmbH
Hauptsitz

Im Gut 1
79790 Küssaberg
Deutschland

Telefon +49 7742 8001-0
Telefax +49 7742 6901

Semitron Swiss AG
Niederlassung Schweiz

Promenadenstrasse 6
5330 Bad Zurzach
Schweiz

Telefon +41 56 269 6040
Telefax +41 56 249 3569

Semitron W. Röck GmbH
Vertriebsbüro Stuttgart

Holderäckerstraße 4
70499 Stuttgart
Deutschland

Telefon +49 711 806098-3
Telefax +49 711 806098-55

Semitron W. Röck GmbH
Vertriebsbüro Quickborn

Kieler Straße 38
25451 Quickborn
Deutschland

Telefon +49 4106 620608
Telefax +49 4106 621778

©2019 Analog Devices, Inc. All rights reserved. Trademarks and registered trademarks are the property of their respective owners. Ahead of What's Possible is a trademark of Analog Devices. G16456-4/19(B)

